

TECHNICAL MANUAL
OPERATOR'S MANUAL
FOR
MULTIPLE INTEGRATED LASER
ENGAGEMENT SYSTEM
(MILES)
SIMULATOR SYSTEM, FIRING, LASER: M78
NSN 1270-01-159-0482
FOR
OH-58 OBSERVATION HELICOPTER

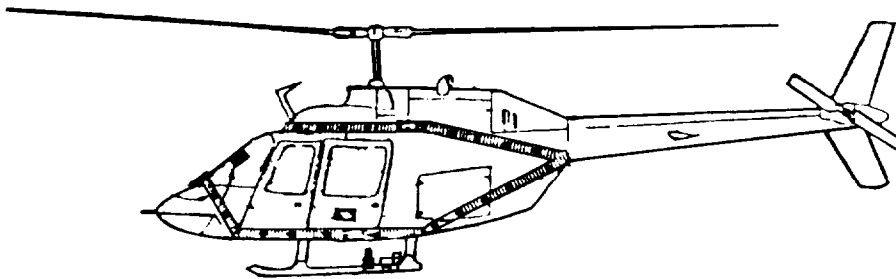

HEADQUARTERS, DEPARTMENT OF THE ARMY
OCTOBER 1984

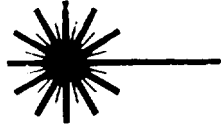

WARNING

Although the laser light emitted by MILES transmitters is considered eye safe by the Bureau of Radiological Health, suitable precautions must be taken to avoid possible eye damage from overexposure to this radiated energy. Precautionary measures include the following:

- Avoid viewing the laser emitter at close range (less than 12 meters). Increasing the eye-to-laser distance greatly reduces the risks of overexposure.
- Avoid viewing the laser emitter directly along the optical axis of the radiated beam.
- Especially avoid viewing the laser emitter through magnifying optics at engagement ranges of less than 75 meters for STINGER, VULCAN, and TOW and 110 meters for the CHAPARRAL.
- Avoid allowing personnel with optics of higher transmission or magnifying power than normal tank optics to view STINGER, Vulcan, or TOW within 150 meters or the CHAPARRAL within 330 meters.

Primer is highly Inflammable. Do not spray near Heat, Sparks, or Open Frame. No Smoking. Use only in well-ventilated area.

Make sure cables are secured below belt and NOT behind it.

Make sure a grenade IS NOT installed in Smoke Indicator.

Do not preflight until all safety switches are set to their SAFE positions.

In inclement weather, you should shut off the AKI strobe to prevent experiencing vertigo during flight. AKI strobe is extinguished with circuit breaker for SIG LT RECT

M18 Smoke Canisters are the ONLY canisters authorized for use with the AKI Smoke Assembly. Care should be taken when handling expended canisters as they are initially hot to the touch. Failure to comply may result in Injury to Personnel.

For Information on FIRST AID, see FM 21-11

TECHNICAL MANUAL
No. 9-1270-222-10

HEADQUARTERS
DEPARTMENT OF THE ARMY
WASHINGTON, D.C.,

22 October 1984

OPERATOR'S MANUAL
FOR
MULTIPLE INTEGRATED LASER ENGAGEMENT SYSTEM
(MILES)
SIMULATOR SYSTEM, FIRING, LASER: M78
NSN 1270-01-159-0482
FOR
OH-58 OBSERVATION HELICOPTER

REPORTING ERRORS AND RECOMMENDING IMPROVEMENTS

You can help improve this manual. If you find any mistakes or if you know of a way to improve the procedures, please let us know. Mail your letter, DA Form 2028 (Recommended Changes to Publications and Blank Forms), or DA Form 2028-2 located in back of this manual direct to: Commander, US Army Armament, Munitions and Chemical Command, ATTN: DRSMC-MAS(R), Rock Island, IL 61299. A reply will be furnished to you.

TABLE OF CONTENTS

	Page
CHAPTER 1 INTRODUCTION	1-1
SECTION I General Information	1-1
SECTION II Equipment Description	1-5
SECTION III Technical Principles of Operation	1-10
CHAPTER 2 OPERATING INSTRUCTIONS	2-1
SECTION I Description and Use of Operator's Controls and Indicators	2-1
SECTION II Preventive Maintenance Checks and Services	2-4
SECTION III Operation Under Usual Conditions	2-7
SECTION IV Operation Under Unusual Conditions	2-82
CHAPTER 3 MAINTENANCE INSTRUCTIONS	3-1
SECTION I Lubrication Instructions	3-1
SECTION II Troubleshooting Procedures	3-1
CHAPTER 4 AMMUNITION	4-1
APPENDIX A REFERENCES	A-1
APPENDIX B COMPONENTS OF END ITEM AND BASIC ISSUE ITEMS LISTS	B-1
APPENDIX C ADDITIONAL AUTHORIZATION LIST	C-1
APPENDIX D EXPENDABLE SUPPLIES AND MATERIALS LIST	D-1
INDEX	Index-1

CHAPTER 1

INTRODUCTION

SECTION I. GENERAL INFORMATION

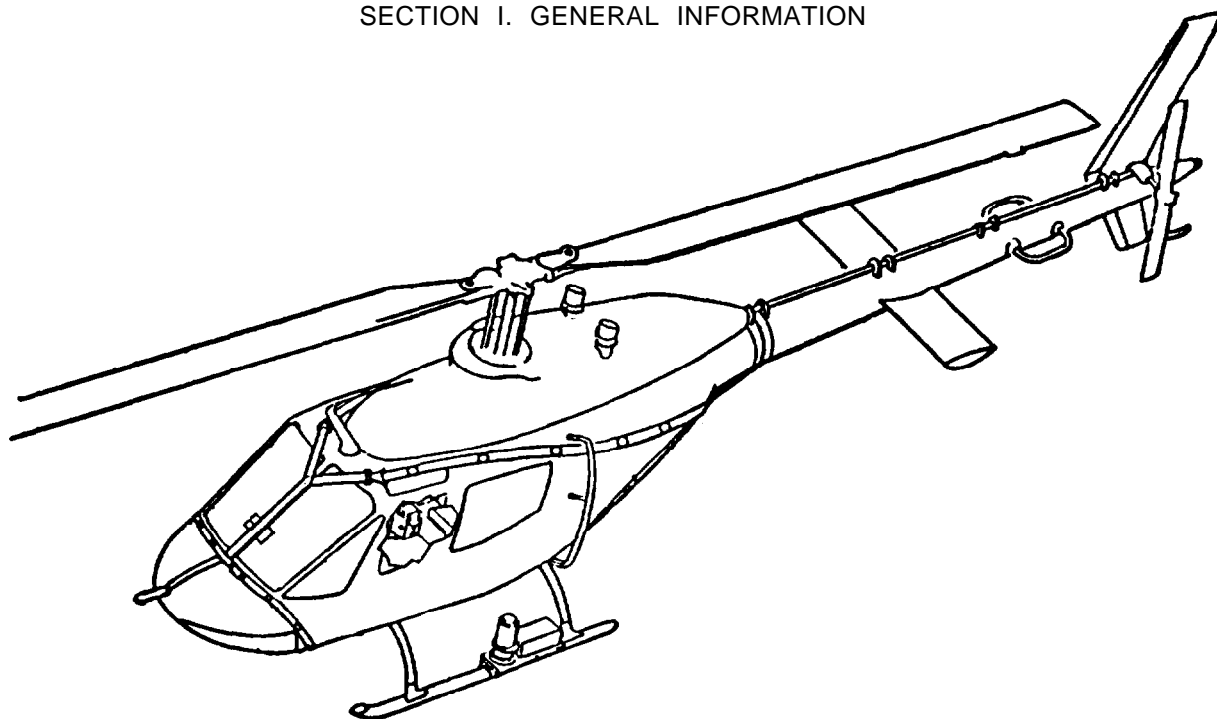

SCOPE

TYPE OF MANUAL. This manual shows you how to install, checkout, operate, and maintain the Multiple Integrated Laser Engagement System (MILES) Air-to-Ground Engagement System/Air Defense (AGES/AD) for the OH-58 Observation Helicopter System.

This manual covers only authorized Operator Maintenance. Any maintenance problems not covered should be referred to Organizational Maintenance personnel.

NOTE

To use this manual you should be able to:

Energize and Maintain the OH-58A and/or OH58C Observation Helicopter (see TM 55-1520-228-10 and/or TM 55-1520-235-10).

Complete DA Forms 2402 and 2404.

If you cannot do these tasks, ask your NCOIC or Instructor to show you how. When you can do all these tasks go on with this manual.

PURPOSE OF EQUIPMENT. MILES AGES/AD equipment for the OH-58 Observation Helicopter consists of a Laser Detection and Warning System. It permits realistic combat training without the hazards of using live ammunition.

LIMITATION ON EQUIPMENT. MILES-equipped weapons have the same range and operational capabilities as the normal weapons but a dirty laser transmitter lens may reduce the effective range of the transmitters.

NOTE

Installation of the MILES AGES/AD Equipment for the OH-58 will affect the Pitot Static System. Error speeds will indicate approximately 5 knots higher than actual, during level flight above 70 knots. The altimeter will indicate approximately 25 feet higher than actual, at airspeeds from 70-100 knots and approximately 60 feet higher than actual, at airspeeds above 100 knots.

More details is presented in the Aircraft Operators Manual.
(See TM55-1520-228-10 and/or TM55-1520-235-10)

MAINTENANCE FORMS AND RECORDS. Department of the Army forms and procedures used for equipment maintenance will be those prescribed by DA PAM 738-750. The Army Maintenance Management System (TAMMS).

HAND RECEIPT MANUAL. This manual has a companion document with a TM number followed by "-HR" (which stands for Hand Receipt). The TM 9-1270-222-10-HR consists of preprinted hand receipts (DA Form 2062) that list end item related equipment (i.e., COEI, BII, and AAL) you must account for. As an aid to property accountability, additional -HR manuals may be requisitioned from the following source in accordance with procedures in Chapter 3, AR 310-2.

Commander

The U.S. Army Adjutant General Publications Center

2800 Eastern Boulevard

Baltimore MD 21220

REPORTING EQUIPMENT IMPROVEMENT RECOMMENDATIONS (EIRs). If your MILES equipment for the OH-58 Observation Helicopter needs improvement, let us know. Send us an EIR. You, the user, are the only one who can tell us what you don't like about your equipment. Let us know why you don't like the design or performance. Put it on an SF 368 (Quality Deficiency Report). Mail the Quality Deficiency Report to us at Commander, US. Army Armament. Munitions and Chemical Command. ATTN: DRSMC-MAO(R), Rock Island. IL 61299. We'll send you a reply.

REFERENCE INFORMATION

NOMENCLATURE CROSS REFERENCE LIST

<u>Common Name</u>	<u>Official Nomenclature</u>
Aircraft Control Indicator (ACIA)	Adapter Assembly, Simulator System, Laser: Console
Aircraft Kill Indicator (AKI)	Indicator, Simulator System, Laser: Aircraft Kill
Adapter Set	Adapter Set, Simulator System, Laser: OH-58 Helicopter
Battery Box	Battery Box Assembly
Cockpit Kill Indicator (CKI)	Adapter Assembly, Cockpit Kill Indicator
Detector Belt	Detector Belt Assembly. Aircraft Segments No. 5, 6, and 7
OH-58 Simulator	Simulator System, Firing Laser: M78 for OH-58 Helicopter
Smoke Indicator	Indicator, Simulator System, Laser: Smoke

LIST OF ABBREVIATIONS

AGES/AD	Air-to-Ground Engagement System/Air Defense
ACIA	Aircraft Control Indicator Assembly
AKI	Aircraft Kill Indicator
CKI	Cockpit Kill Indicator
IR	Infrared
MILES	Multiple Integrated Laser Engagement System
PMCS	Preventive Maintenance Checks and Services

GLOSSARY

Aircraft Control Indicator Assembly	Receives detected laser pulse signals from externally mounted detector belts. Decodes these signals and activates appropriate audio and visual alarms associated with the AKI/Smoke Assembly and intercom. Displays information on attacking weaponry.
Aircraft Kill Indicator (AKI)	Provides external flashing signal light which indicates that helicopter is under opposing fire ("NEAR MISS"), has been "HIT" or "KILLED." Attaches to left skid.

GLOSSARY (Continued)

Cockpit Kill Indicator (CKI)	Contains electronic circuitry that actuates AKI and intercom warning signals. Also contains key receptacle for testing and actuating system and an emergency system OFF switch. Located in cockpit.
Controller	Umpire or referee in a MILES training exercise.
Controller Gun	Device used to test MILES detector systems. Also used to disqualify soldiers or vehicles from an exercise.
Controller Key	Green key used by Controller to reset MILES transmitters and control consoles.
Detector Belt	Device that senses laser beams directed at it.
Fastener Tape	Hook and pile tape. Used to hold vehicle detector belts and other MILES equipment in place.
Hit	Simulated contact with opposing fire insufficient to disable vehicle or cause a fatality.
Kill	Simulated contact with opposing fire sufficient to disable vehicle or cause a fatality.
Laser	Light Amplification by Stimulated Emission of Radiation.
Laser Beam	Invisible beam of light which simulates weapon fire.
Laser Detector Assembly	Device that senses laser beams directed at it
Laser Transmitter	Device that sends a laser beam
Near Miss	Simulated closeness to contact with opposing fire.
Simulator	Training device which takes the place of real equipment and which has many of its characteristics.
Smoke Indicator	Contains a smoke grenade that is ignited when the OH-58 has been "KILLED." Attaches to left skid adjacent to the AKI.

SECTION II. EQUIPMENT DESCRIPTION

EQUIPMENT CHARACTERISTICS, CAPABILITIES, AND FEATURES

PURPOSE OF MILES SIMULATOR SYSTEM, LASER: OH-58 OBSERVATION HELICOPTER

The MILES Simulator System, Laser: OH-58 Observation Helicopter permits the helicopter and Aircrew to take part in realistic combat training exercises.

Laser detectors mounted on the helicopter exterior sense enemy fire. MILES system electronics determine the accuracy and simulated damage of enemy fire. The system also detects the type of weapon directing enemy fire against the OH-58. A Smoke Indicator Device adds to the system's realism.

FEATURES AND CAPABILITIES

- Easily installed and removed.
- Adapters for OH-58A and 58C Aircraft models.
- Smoke Indicator Device adds realism.
- Detects all opposing fire.
 1. Attacking weapon accuracy
 - a. "NEAR MISS"
 - b. "HIT"
 - c. "KILL"
 2. Attacking weapon identification.
- Uses eye safe battery-powered laser transmitters.
- Operates in temperatures from 35°C (-31°F) to 62°C (144°F).
- Compatible with all other MILES training devices.
- High visibility CVKI stobe light signals vehicle "NEAR MISS" "HIT" or "KILL."

LOCATION AND DESCRIPTION OF MAJOR COMPONENTS.

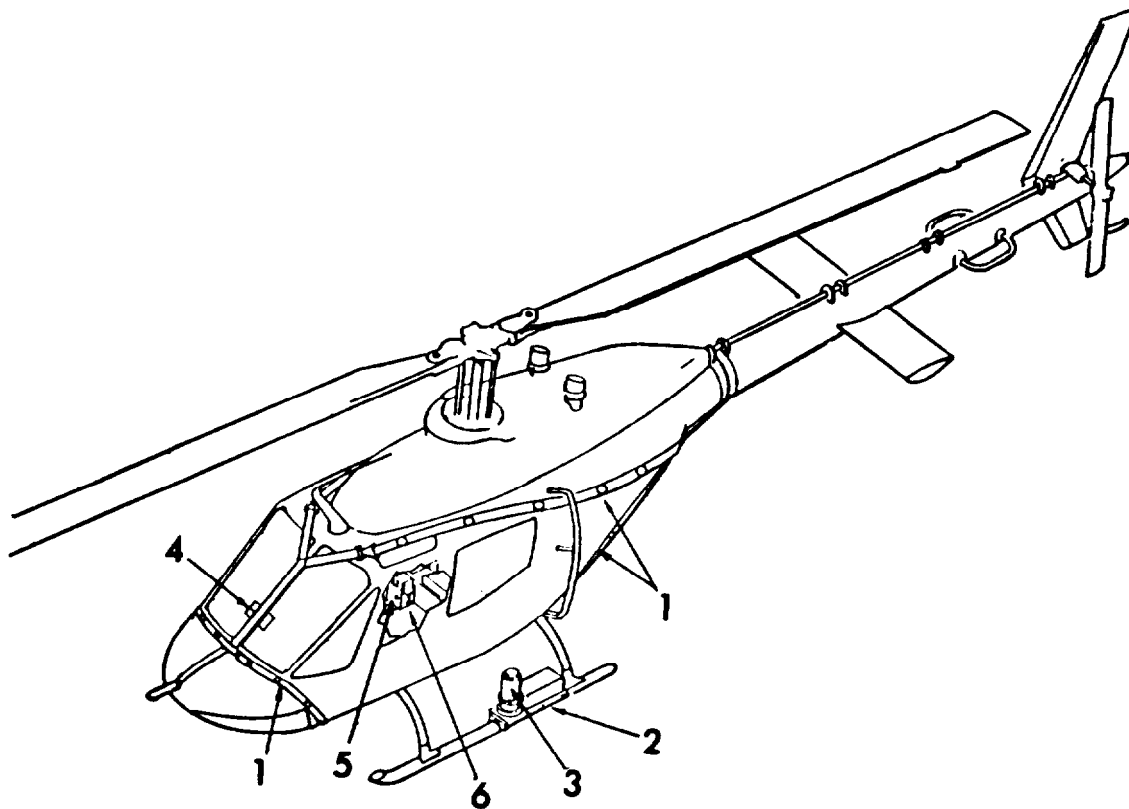

Detection Belt System (1). Receives laser pulses from AGES/AD and MILES-equipped opposing weapons. Generates, amplifies and routes electrical signals to Aircraft Control Indicator Assembly (ACIA) for determining whether signal was a "NEAR MISS", "HIT" or "KILL." Mounts on nose, top, sides and bottom of helicopter fuselage.

Smoke Indicator (2). Contains smoke grenade that is ignited when the OH-58 has been "KILLED." Mounts on left skid adjacent to Aircraft Kill Indicator (AKI). Operates on 24 V dc aircraft power.

Aircraft Kill Indicator (AKI) (3). Provides a flashing light to indicate to other Aircraft Vehicles, and Ground Troops that the OH-58 has received a "NEAR MISS", "HIT", or "KILL." The AKI bolts to the left skid. and operates on 24 V dc Aircraft Power.

LOCATION AND DESCRIPTION OF MAJOR COMPONENTS (Cont)

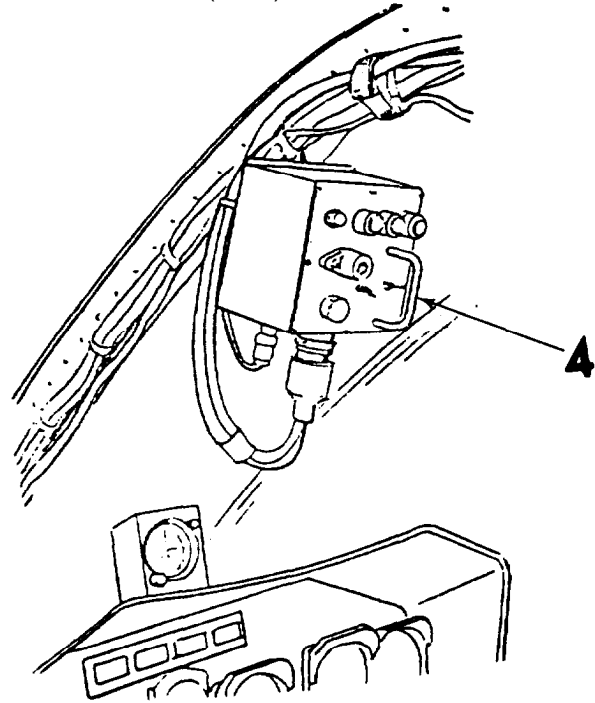

Cockpit Kill Indicator CKI (4). Contains lights to indicate an “ENGAGE,” or “KILL”, a system ON/OFF switch, volume control for adjusting tone in intercom, receptacle to accept Controller’s Reset Key, and a switch to dim indicator lights. Mounts above instrument panel on center windshield retainer.

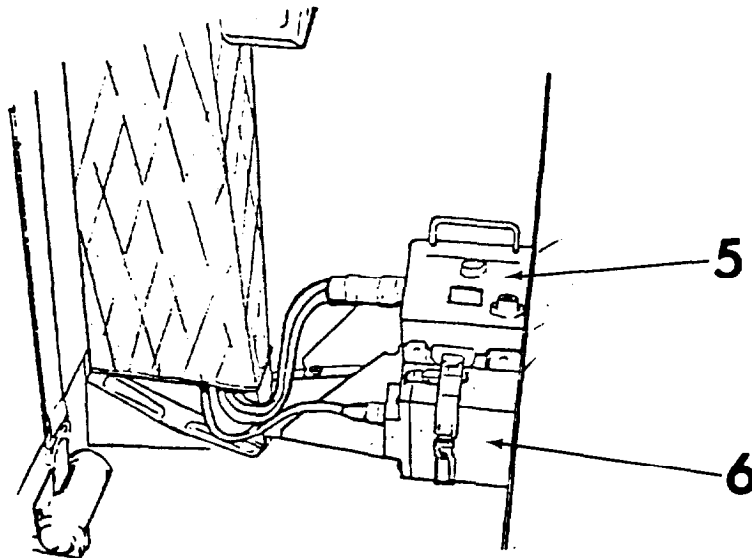

Aircraft Control Indicator Assembly ACIA (5). Receives laser pulse signals from detector belts. Decodes these signals, and actuates appropriate audio and visual alarms. Has key receptacle for initializing and resetting system. In case of a “HIT” or “KILL”, displays a number that identifies attacking weapon type. Mounts on passenger compartment floor.

Battery Box (6). Contains two 6V batteries for operating the ACIA, detection system, CKI and AKI. Mounts against ACIA.

EQUIPMENT DATA

Table 1-1. MILES OH-58 Helicopter Technical Characteristics

Item	System Requirements
Power	12 V dc 24 V dc (AKI)
Reset/Initialization	Controller Key

Table 1-2. MILES OH-58. Helicopter Major Component Weights and Dimensions

Item	Weight (Pounds)	Dimensions (inches)	Number of Detectors
ACIA, Battery Box and Battery	15.5	11.5 x 10.5 x 12.0	
AKI/Smoke Assembly	24.0	20.1 x 7.0 x 15.0	
CKI	2.0	11.5 x 4.5 x 8.5	
Detector Belt Segment No. 5	3.8	145 x 5.0 x 1.5	7
Detector Belt Segment No. 6	4.25	143 x 5.0 x 1.5	8
Detector Belt Segment No. 7	6.3	114 x 5.0 x 1.5 75 x 190 x 1.0	6

Table 1-3. MILES OH-58 Helicopter Weights and Balances

MILES AGES/AD Equipment	Weight (Pounds)	MOM X100
Top Right Detector Belt # 6	4.25	5.7
Bottom Right Detector Belt # 5	3.8	5.1
Top Left Detector Belt # 6	4.25	5.7
Bottom Left Detector Belt # 5	3.8	5.1
Nose Detector Belt # 7	6.3	2.1
Rear Harness	2.3	4.5
CKI	2	.9
ACIA, Battery Box and Battery	15.5	14.3
AKI/Smoke Assembly	24	27.6
Cables	5.6	5
Tie Down Rings (2) .25 x 2 = 5	.5	.3
TOTALS	72.3	76.3

SECTION III. TECHNICAL PRINCIPLES OF OPERATION

BASIC PRINCIPLES OF OPERATION

The MILES system uses semiconductor laser beams to simulate actual weapon fire. An eye-safe invisible laser beam is sent out by each weapon's transmitter when it is fired. The laser beam is coded and simulates all of the weapon's capabilities including range, accuracy and destructive capability.

Laser detector systems are used to sense opposing fire. The detection systems detect opposing laser beams and determine whether they have scored a "NEAR MISS," "HIT" or "KILL." The systems activate alarms indicating the presence and damage of opposing fire.

The MILES system of laser beam transmitters and detectors allows safe realistic training exercises with a complete range of weaponry and vehicles.

OH-58 OBSERVATION HELICOPTER CONFIGURATION

The OH-58 Observation Helicopter exterior has special detector belts attached that sense opposing fire. An Aircraft Control Indicator Assembly (ACIA) mounted inside the helicopter determines the extent of fire and its effect. An Aircraft Kill Indicator (AKI) mounted on the helicopter's left skid is actuated by the ACIA when opposing fire is detected. A Smoke indicator is activated when the opposing fire scores a "KILL." Adapters allow equipment to be used on both OH-58A and OH-58C configurations.

HELICOPTER DETECTION SYSTEM

Five detector belt segments containing detectors are mounted on the nose, sides, top and bottom of the OH-58 fuselage. Opposing fire is sensed by the detectors. They generate electrical signals that are routed to a decoder in the ACIA.

The decoder identifies the type of weapon that fired the opposing laser beam. It determines whether the laser shot was accurate enough to cause an "ENGAGE" situation. An "ENGAGE" lamp on the Cockpit Kill Indicator (CKI) is lit for either a "HIT" or "NEAR MISS." It also determines if the weapon was capable of causing damage to the target, (an M16 rifle, for example, cannot disable a tank) and the probability of "KILL" for that weapon. The probability of "KILLING" a target is different for each attacking weapon. The CKI KILL lamp is lit for a "KILL."

If a detector on the OH-58 is Hit by laser fire one of three things will happen:

1. Two tones will sound in the helicopter's intercom and AKI light mounted on the left skid will flash two times. This means a "NEAR MISS" occurred. The CKI ENGAGE light will come on.
2. Four to six tones will sound in the intercom and AKI light will flash four or six times. This means a "HIT" but not a "KILL" occurred. The CKI ENGAGE light will come on.
3. The intercom tone will sound continuously and AKI light will flash continuously. An M18 smoke grenade located on the Smoke Indicator Assembly mounted on the left skid will be set off. This means a "KILL" occurred. The CKI KILL light will come on.

The helicopter crew can determine what type of weapon has fired on them by setting the switch on the ACIA and pushing the display button. A code number will appear on the display indicating the attacking weapon following a "HIT" or "KILL." No code number appears for a "NEAR MISS."

The volume of the intercom tone may be turned down after a "KILL" by turning the VOLUME knob on the CKI. The AKI light continues to flash until reset by a Controller. In inclement weather the AKI may be extinguished with the SIG LT RECT circuit breaker.

CHAPTER 2

OPERATING INSTRUCTIONS

SCOPE.

This Chapter provides those instructions needed by the Aircraft Crew to install, test, operate, and remove the MILES OH-58 equipment.

SECTION I. DESCRIPTION AND USE OF OPERATOR'S CONTROLS AND INDICATORS

MILES OH-58 CONTROLS AND INDICATORS. The MILES OH-58 Controls and Indicators are only those associated with the Aircraft Control Indicator Assembly (ACIA) and Cockpit Kill Indicator Assembly (CKI). All other Controls and Indicators are those actually associated with the OH-58 Observation Helicopter.

COCKPIT KILL INDICATOR (CKI) CONTROLS AND INDICATORS. Controls and Indicators for the CKI are listed in Table 2-1.

Table 2-1. Cockpit Kill Indicator Controls and Indicators

Key	Description	Function	Operating Position
1	KILL	Lights when detection system receives "KILL" Indication.	Adjustable iris normally open. Dim when using night goggles.
2	ENGAGE	Lights when detection system receives "HIT" or "NEAR MISS" indication.	Adjustable iris normally open. Dim when using night goggles.
3	RESET	Resets ENGAGE light following a "HIT" or "NEAR MISS."	
4	CONTROLLER	Resets/turns system on.	Used by Controller and maintenance personnel only.
5	VOLUME	Adjusts loudness of MILES tone in intercom.	As required.
6	LAMP IND	Changes brightness of CKI lamps.	NORM - during daylight operations. DIM during night operations.
7	MISSILE TRACK	Not Used.	
8	SYSTEM	Turns off MILES system in case of an emergency.	ON

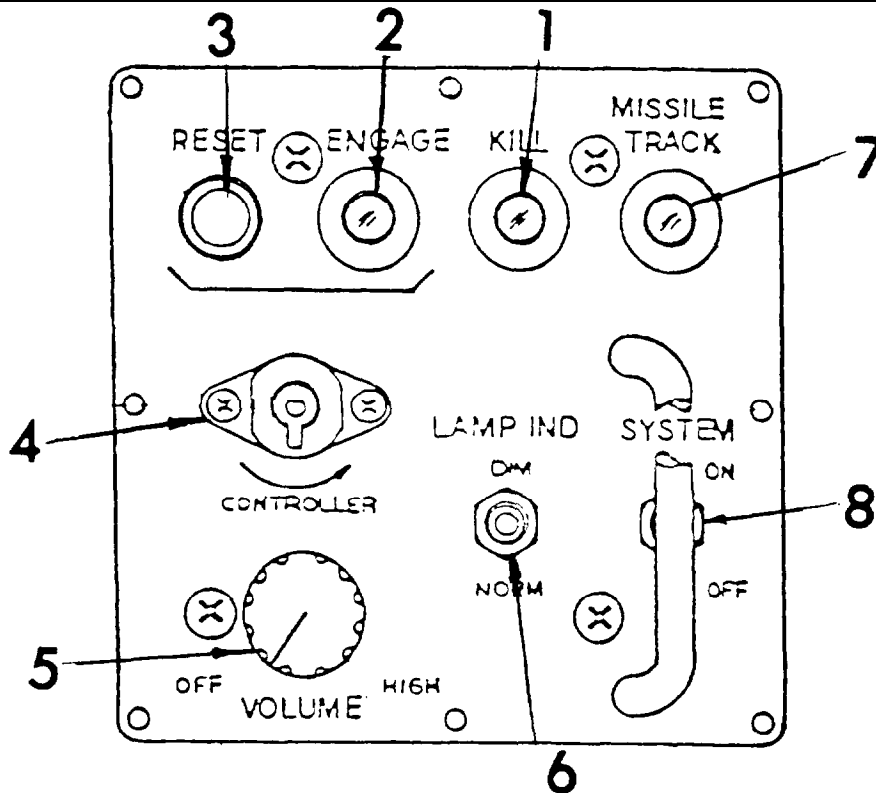

CKI Controls and Indicators

AIRCRAFT CONTROL INDICATOR ASSEMBLY (ACIA) CONTROLS AND INDICATORS. Controls and indicators for the ACIA are listed in Table 2-2

Table 2-2. Aircraft Control Indicator Assembly Controls and Indicators

Key	Description	Function	Operating Position
1	SELF TEST	Performs Self Test.	Turn to SELF TEST. Press PRESS TO READ. Display should read 88.
2	HIT/KILL WPN IDENT	Identifies weapon firing on you.	Turn to HIT/KILL. Press PRESS TO READ. Display will show a number.
3	DISPLAY	Displays numbers.	
4	WEAPON/ CONTROLLER	Resets system.	Turn Controller Key to CONTROLLER position to reset system. (Performed only by Controller).
5	PRESS TO READ	Activates display.	Press to activate display.
6	NOT READY	Lights when not ready or "KILLED."	

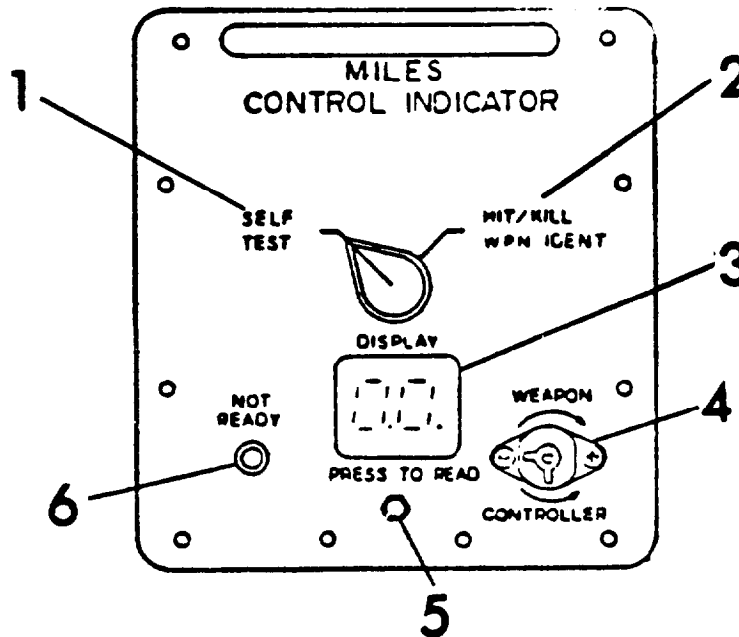

ACIA Controls and Indicators

SECTION II. PREVENTIVE MAINTENANCE CHECKS AND SERVICES

GENERAL. Preventive Maintenance Checks and Services will ensure that the MILES equipment will always be ready for operation and perform satisfactorily throughout its mission. Preventive maintenance checks consist of performing a systematic inspection to discover defects before they result in operational failure of the equipment. Defects or malfunctions discovered by the crew during use of the MILES equipment, or as a result of performing maintenance checks and services, will be reported using the proper forms (refer to DA PAM 738-750).

- (1) Before you operate. Always keep in mind the CAUTIONS and WARNINGS. Perform your Before (B) PMCS
- (2) While you operate. Always keep in mind the CAUTIONS and WARNINGS. Perform your During (D) PMCS
- (3) After you operate. Be sure to perform your After (A) PMCS
- (4) If your equipment fails to operate. troubleshoot with proper equipment. Ask your Controller to check your equipment Report any deficiencies using the proper forms.

Table 2-3. Operator/Crew Preventive Maintenance Checks and Services

Item No.	Interval					Item to be Inspected	Procedures - Check for and have repaired or adjusted as necessary	Equipment is Not Ready/ Available if:
	B	D	A	W	M			
1	•					Batteries	Inspect for acid leaks.	Acid is present.
2	•	•				Battery Box	Inspect for damaged connectors. Check that connectors and interior battery contacts are serviceable.	Damage would prevent normal operation.
3	•	•				Cable Assemblies (5)	Check for broken connectors and cut, worn or bare wiring.	Connectors are broken or wire is cut or bare.
4	•	•				ACIA	Inspect for cracks in Display Window. Check that Controller's key turns freely in MODE SELECT receptacle.	Display window is cracked. Controller's key does not turn freely.
5	•	•				Detector Belt Segments (5)	Inspect for evidence of switch damage. Look for loose or cracked detectors or damaged connectors.	Switch is damaged. Detectors are loose or cracked; connectors are damaged.
6	•	•				AKI/Smoke	Inspect for cracks in plastic lens. Inspect for damaged receptacle. Inspect for stripped mounting bracket threads.	Lens is cracked. Receptacle is damaged. AKI cannot be securely mounted.
7	•		•				Inspect for damaged hinge and latch. Inspect for presence of grenade.	Hinge binds or latch will not engage. Grenade is present.

Table 2-3. Operator/Crew Preventive Maintenance Checks and Services (Cont)

B - Before Operation		D - During Operation			A - After Operation		W - Weekly Operation		M - Monthly Operation	
Item No.	Interval					Item to be Inspected	Procedures - Check for and have repaired or adjusted as necessary	Equipment is Not Ready/ Available if:		
	B	D	A	W	M					
7		•				CKI	<p>Inspect lamps for proper operation.</p> <p>Check that Controller Key turns freely in WEAPON KEY receptacle.</p> <p>Inspect for evidence of switch damage.</p>	<p>Lamps operate correctly.</p> <p>Controller Key does not turn freely.</p> <p>Switch is damaged.</p>		

SECTION III. OPERATION UNDER USUAL CONDITIONS

GENERAL. Before the MILES equipment can be used, it must be properly installed on the OH-58. To speed up procedures, work is organized into various tasks. While some crew members are performing one set of tasks, others can be performing another set.

Before you begin, READ ALL STEPS IN THE TASK AND LOOK AT EACH ILLUSTRATION CAREFULLY. To help perform a task, most steps have reference numbers to drawings. Do each step just the way you are instructed and in the order in which it occurs in this manual.

NOTE

Don't jump ahead. Don't skip any steps.

If your MILES equipment has a problem you can't fix using this manual, report it on DA Form 2404. To get a replacement, turn in the faulty equipment and the completed form.

TASK ASSIGNMENT. The Crew Chief assigns crewmen to tasks. The crewman turns to the appropriate Section in this manual and performs the required steps IN ORDER. Occasionally, the manual may tell a crewman to wait until he has made sure that another crewman has completed an earlier task. On some tasks, two crewmen may have to work together.

Start at Task 1 after reading the Task Assignment.

Certain steps must be done with the Controller present. A Controller Key, carried only by the Controller, is required to reset the system. The Crew Chief will determine when to call the Controller. The Controller may also supply a Orange Weapon Key when needed for Inspection and Test Tasks.

Those tasks involving the Controller must be done in this order:

1. Test Tasks (See page 2-62)
2. Operational Tasks 2 (Initialize MILES System) 3 (Install Smoke Grenade), 6 (Recognizing Enemy Fire), and 7 (Resetting After a "KILL") (See pages 2-72, 2-73, 2-75, 2-77)

The Crew Chief should coordinate the tasks, give assistance to any crewman who needs it, and check to make sure everything gets done.

NOTE

Unless otherwise indicated, references in this manual to right and left sides of the OH-58 Observation Helicopter use the seated Pilot as a standard point of reference.

LIST OF TASKS

<u>Tasks</u>	<u>Page</u>
<u>Assembly and Preparation for Use</u>	
Preinstallation Task	2-8
Outside Preparation Tasks	2-9
Outside Installation Tasks	2-14
Inside Installation Tasks	2-40
Cabling Installation Tasks	2-46
<u>Initial Adjustments, Daily Checks and Self Test</u>	
Alignment Task	2-61
Test Tasks	2-62
<u>Operating Procedure</u>	
Operational Tasks	2-68
Postoperational Tasks	2-79

NOTE

Minimum vehicle temperature for cleaning and priming is approximately 32°F.

Preinstallation Task

Obtain all equipment needed to install and operate MILES OH-58 Observation Helicopter system from your NCOIC. Unpack MILES transit case. Verify that all equipment is present and not visibly damaged. Check against illustrations in Appendix B, Components of End Item.

Obtain all Support Equipment (Appendix C) and all Expendable/Durable Supplies and Materials (Appendix D).

Connect OH-58 battery cables to battery.

OUTSIDE PREPARATION TASKS - LIST

<u>Task</u>	<u>Title</u>	<u>Page</u>
1.	Obtain Equipment	2-9
2.	Install Ring Assemblies	2-10
3.	Install Fastener Tape	2-11

Outside Preparation Task 1: Obtain Equipment. Completion of Outside Preparation Tasks requires equipment illustrated below. Locate and set aside this equipment.

Installation Kit - 1 can of Primer and 1 roll of Fastener Tape (For resupply of either item, see Appendix D).

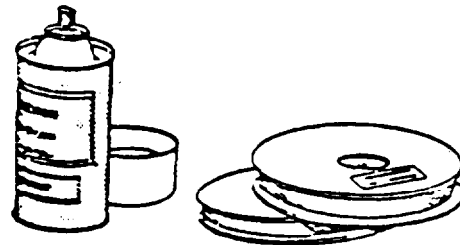

Two Ring Assemblies (2) and four flat washers (3), four lock washers (4), two hex nuts (5) and two hatch pins (6).

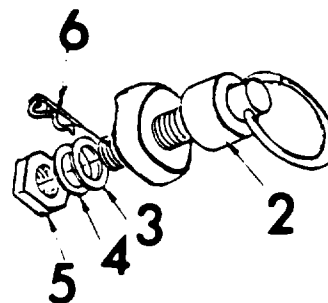

Outside Preparation Task 2: Install Ring Assemblies.

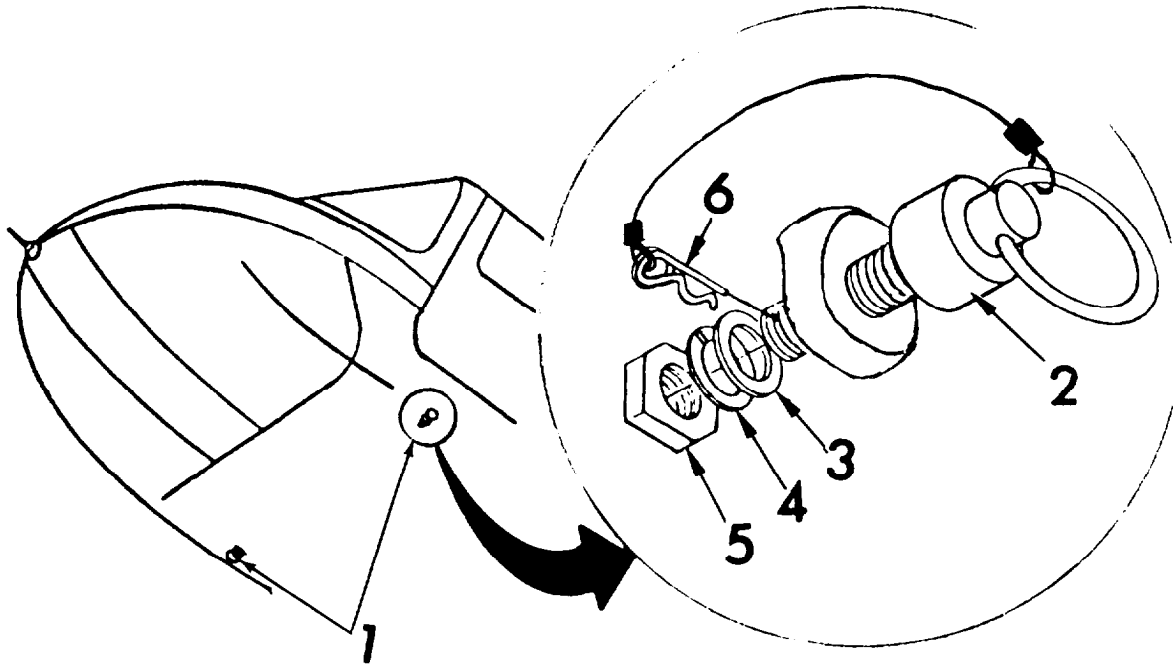

Ring assemblies must be installed on the aircraft to provide mounting points for the bottom belts and nose belt.

With ring toward the outside, install ring assemblies (2) to both forward tiedown fittings (1) using flat washers (3) (Item 3-I, Section II, Appendix B), lock washers (4) (Item 3-J, Section II, Appendix B), and hex nuts (5) (Item 3-G, Section II, Appendix B).

Secure rings with the attached hatch pins (6).

Outside Preparation Task 3: Install Fastener Tape. Hook fastener tape must be installed on the helicopter as a base for securing the upper detector belts.

NOTE

Tape may already be in place from a previous installation. If so check condition of tape and ensure that it is still securely adhered to fuselage. If existing tape is loose or damaged replace with new tape.

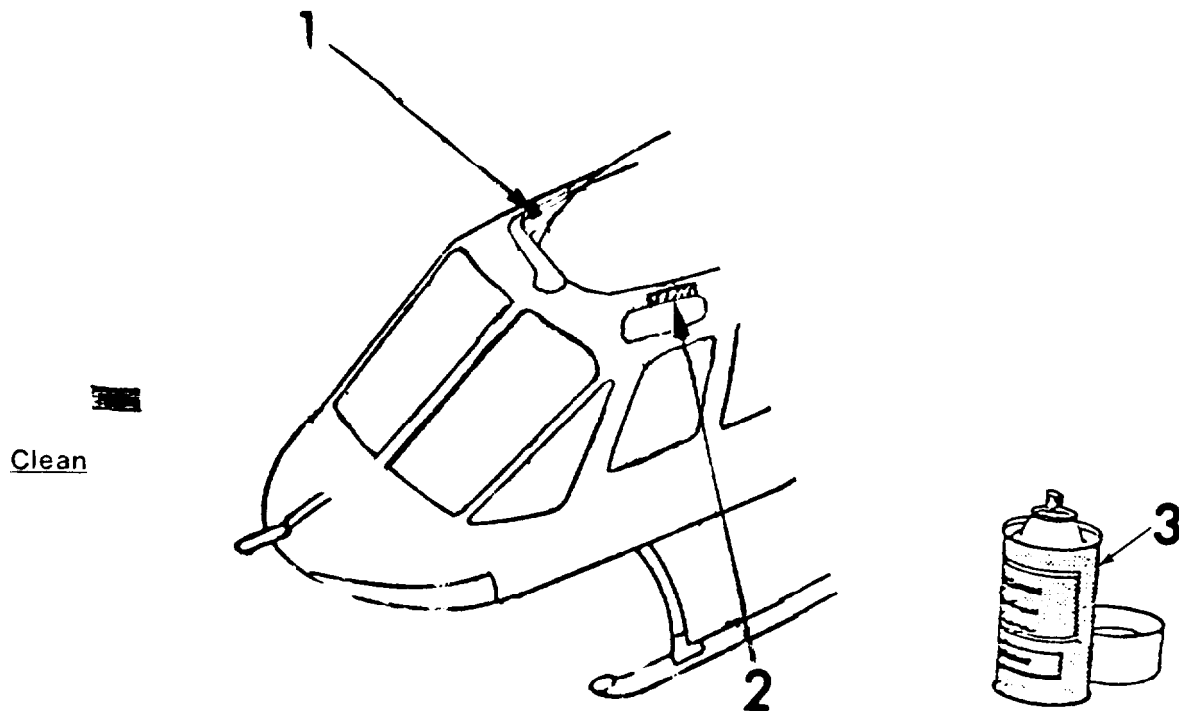

Use brush and rags (Items 4 and 6, Appendix D), clean sections of fuselage (1) and (2) where fastener tape will be installed. Tape will not stick on dirty or greasy surfaces.

Cover nearby glass to prevent overspray

WARNING

Primer is highly inflammable. Do not spray near Heat, Sparks, or Open Flame. No Smoking. Use only in well, ventilated area.

Spray a heavy coat of tape primer (3) on cleaned areas of fuselage (1) and (2). Allow sprayed area to dry for 3 to 5 minutes before applying fastener tape.

Outside Preparation Task 3: Install Fastener Tape (Cont)

Cut two 6-inch pieces of hook fastener tape (4)

Remove protective paper backing from one 6-inch piece of tape. RETAIN PAPER BACKING

Install tape on upper fuselage (5) between forward transmission fairing and skylight. Front of tape should be approximately 8 inches to rear of front edge of skylight.

After you put tape in place, press it VERY HARD with hand roller (G)(Section II, Appendix C). Trim tape at transmission cowling so tape will lie flat on fuselage.

Install second piece of tape in same location on opposite side of helicopter (7).

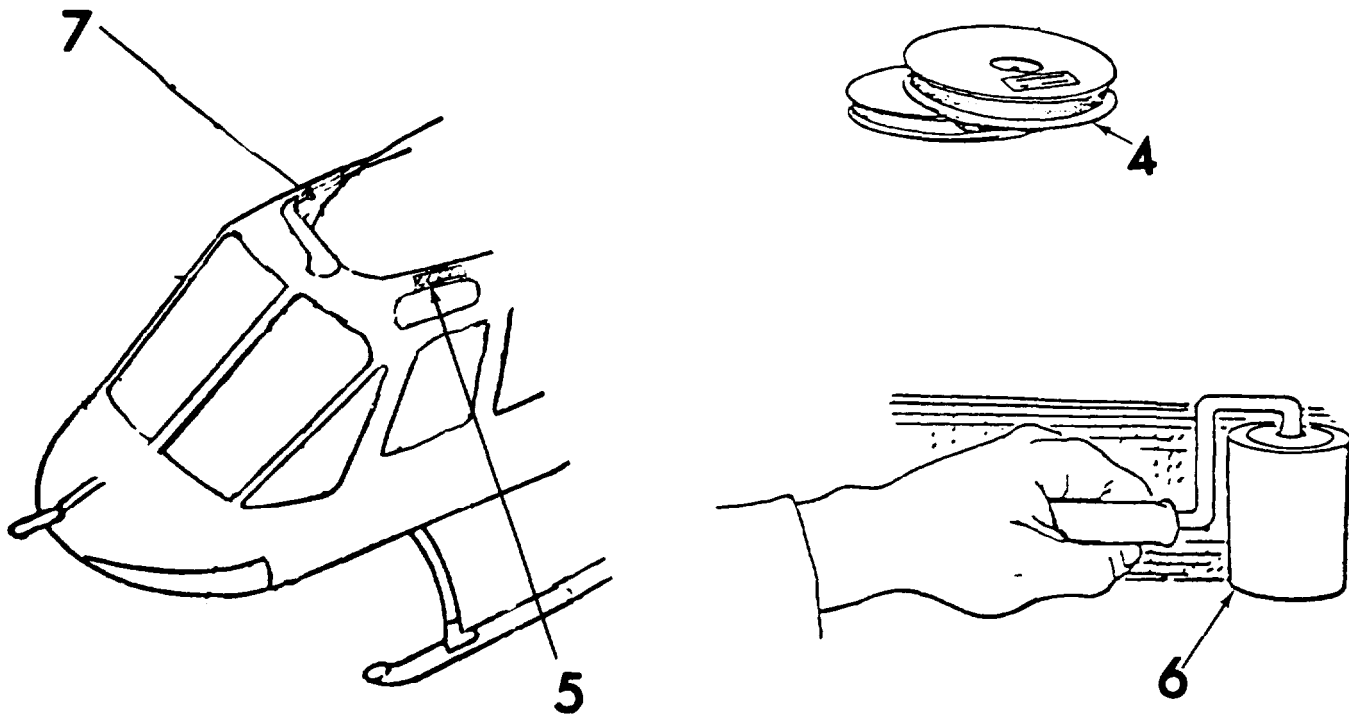

Secure paper backing to hook side of both pieces of fastener tape using small pieces of masking tape (Item 7, Section II, Appendix D). This prevents fastener tape from being sheared when detector belt tension is adjusted.

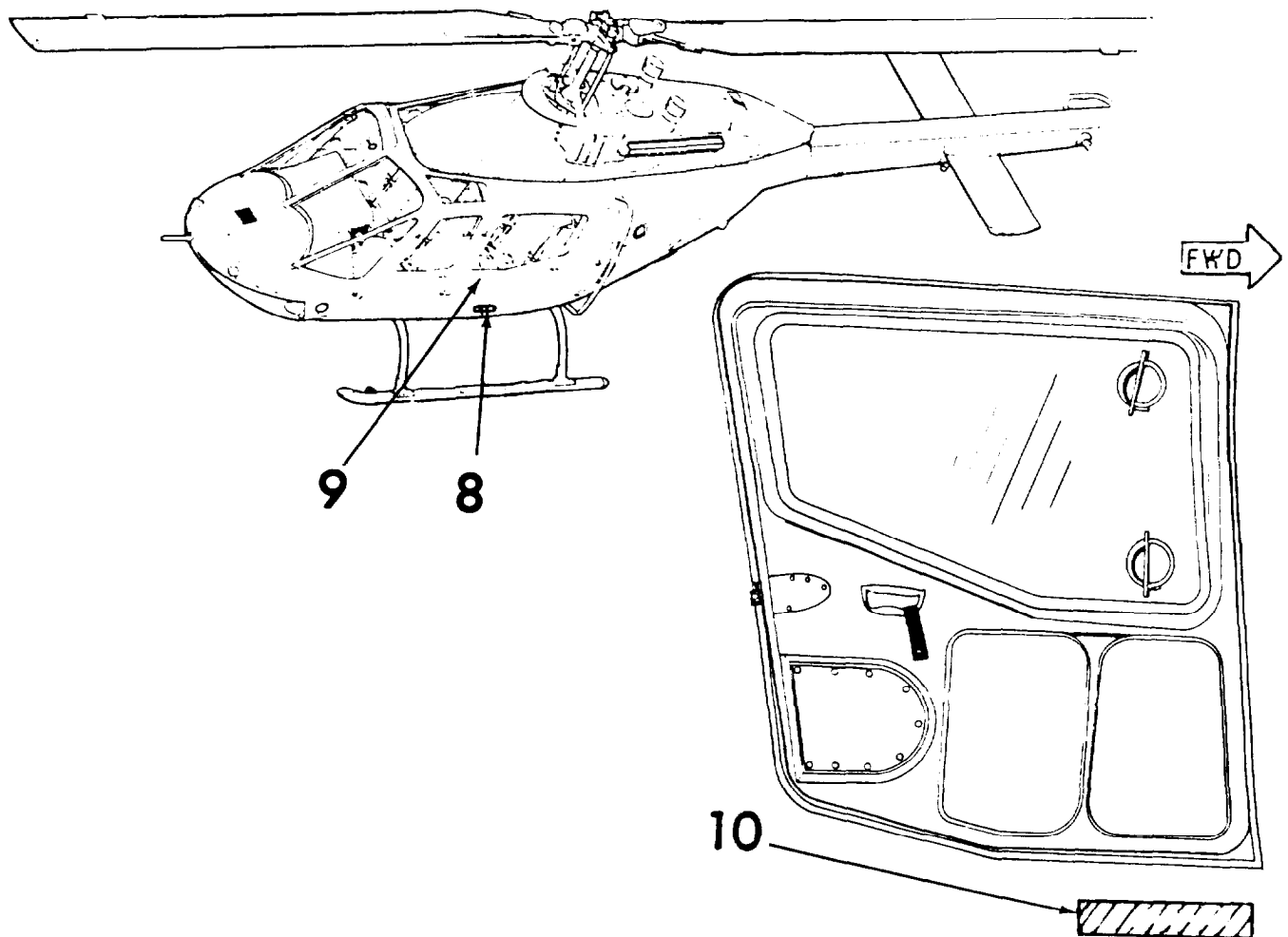

Clean an area (8) on fuselage below left passenger door (9) approximately 16 inches long.

Clean an area inside cabin below left passenger door (10) approximately 16 inches long.

Spray primer on cleaned areas.

Cut two 16-inch strips of fastener tape.

Remove protective paper backing from one piece of tape. Install tape strip (8) on left fuselage below passenger door (9).

Place second strip (10) of tape below passenger door on helicopter interior.

Press tape VERY HARD with roller.

OUTSIDE INSTALLATION TASKS - LIST

<u>Task</u>	<u>Title</u>	<u>Page</u>
1.	Obtain Equipment	2-15
2.	Inspect and Service Detector Belt Segments	2-17
3.	Install Nose Belt	2-18
4.	Install Rear Harness Assembly	2-21
5.	Install Top Right Detector Belt	2-24
6.	Install Top Left Detector Belt	2-26
7.	Install Bottom Right Detector Belt	2-28
8.	Install Bottom Left Detector Belt	2-30
9.	Adjust Side Detector Belts	2-32
10.	Mate Side Detector Belt Connectors	2-36
11.	Inspect AKI/Smoke Indicator Assembly	2-37
12.	Install AKI/Smoke Indicator Assembly	2-38

Outside Installation Task 1: Obtain Equipment. Completion of Outside Installation Tasks requires equipment listed and illustrated below. Locate and set aside this equipment.

- 1 Detector Belt Segment No. 7

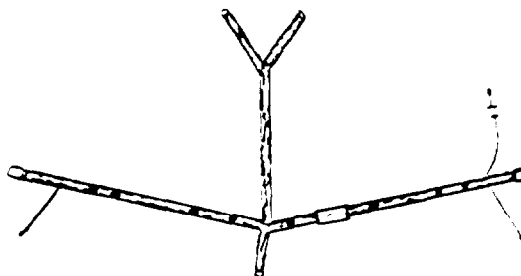

- 2 Detector Belt Segments No. 6

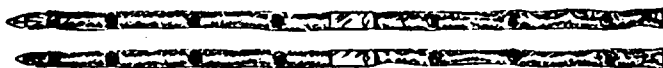

- 2 Detector Belt Segments No. 5

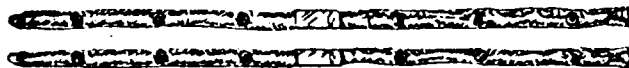

- 2 Belt End Assemblies

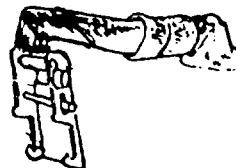

- 1 AKI/Smoke Indicator Assembly

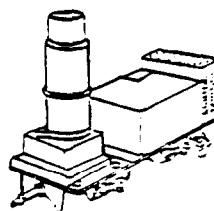

Outside installation Task 1: Obtain Equipment (Cont).

1 Rear Harness Assembly

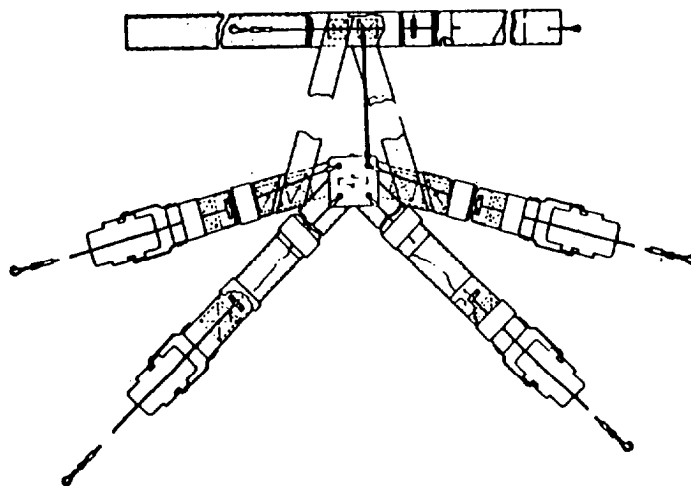

Outside Installation Task 2: Inspect and Service Detector Belt Segments All five detector belt segments must be checked.

Look for any damage that would prevent normal operation of the belt segments (1).

Wipe detectors (2) clean. (Clean all detectors).

Unfasten and open up all fastener tabs (3).

Report any damage on DA Form 2404.

NOTE

Replace belt segments only if not usable.

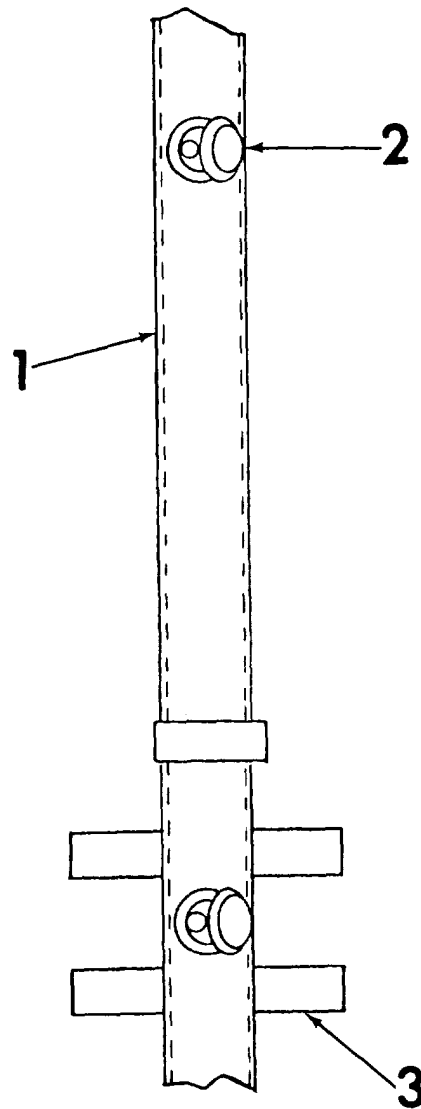

Outside Installation Task 3: Install Nose Belt.

Locate Belt Assembly Segment No. 7

Locate 2 Belt End Assemblies

Attach right hand nose belt buckle (1) to a Belt End Assembly buckle (2). Close and latch buckle (3).

Attach left hand nose belt buckle to buckle of remaining Belt End Assembly.

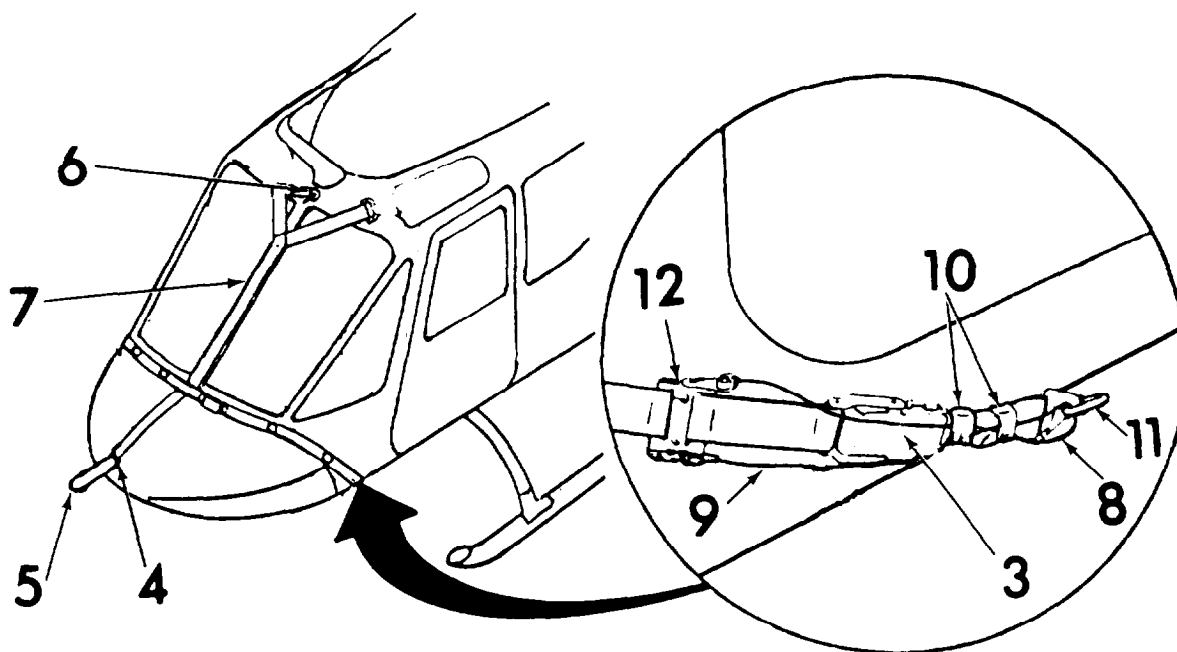
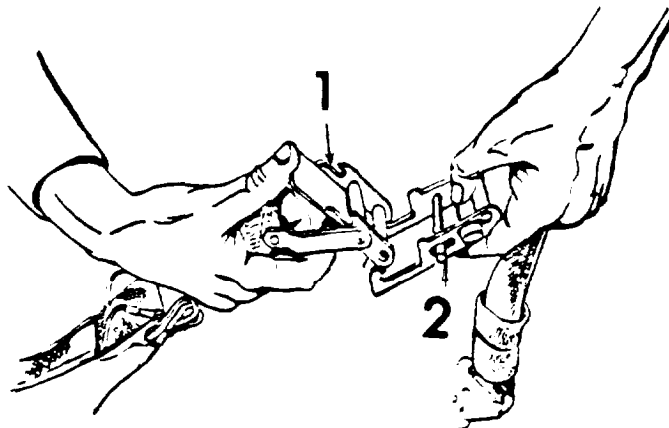

Slip nose belt lower D-ring (4) over pitot tube (5).

Slip nose belt upper right D-ring (6) over tube of free air temperature gage. This temporarily holds nose belt in place.

While one crewman holds stiffened section (7) of nose belt over center windshield retainer, another crewman attaches hook end (8) of left side belt end assembly to left side ring assembly.

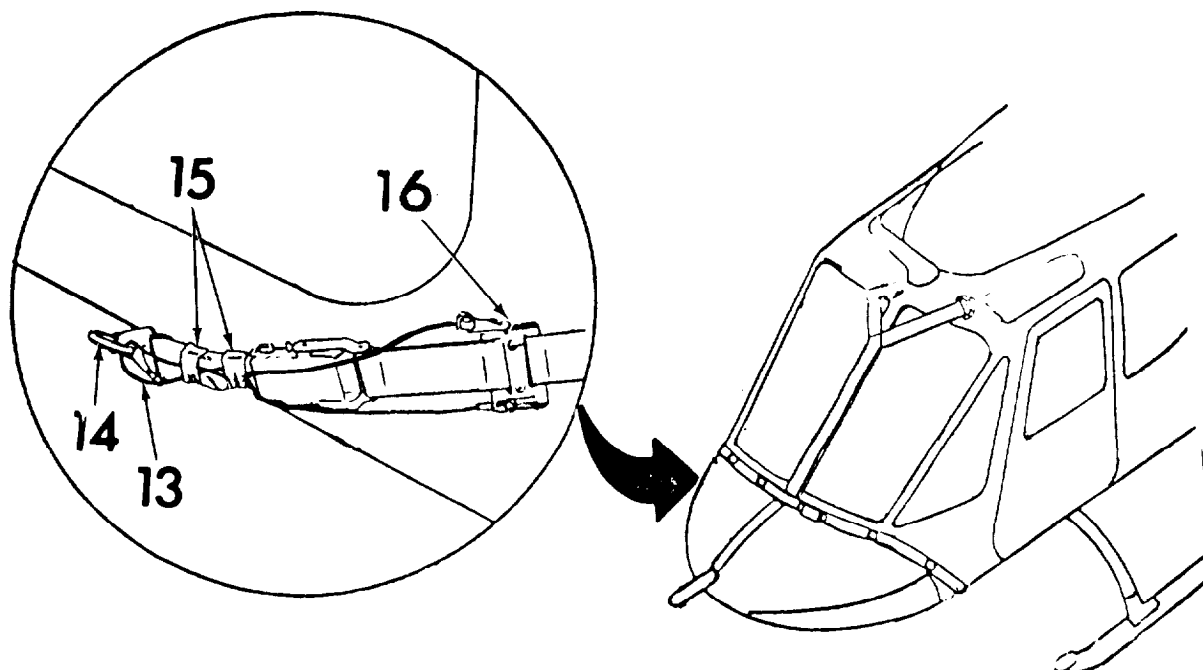

Attach hook end (13) of right side belt end assembly to right side ring assembly (14). Unlatch buckle and position buckle at right angle, see (22) next page.

Adjust tension in nose belt so belt is snug but not tight. Relatch buckle. Do both right and left sides.

To tighten belt. pull running end (17) of belt end assembly. To loosen belt. push belt tension release (18) toward nose belt.

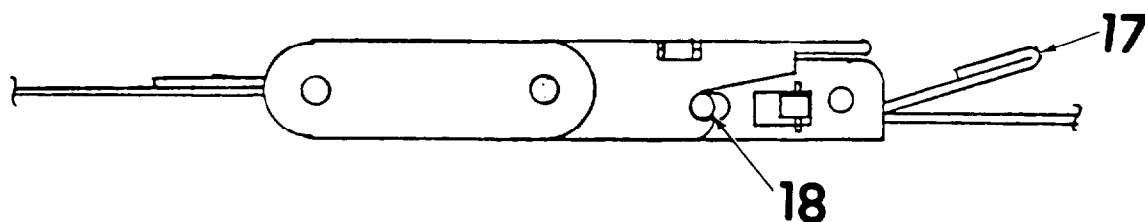

Insert belt safety lanyard (9) through two elastic tabs (10), and thread through left side ring assembly (11). Return lanyard clip through elastic tabs and attach to slot on belt reducer (12).

Insert belt safety lanyard through two elastic tabs (15) then through right side ring assembly. Return lanyard clip through two elastic tabs and attach to slot on belt reducer (16).

Check alignment of nose belt. Stiffened section (19) of nose belt should still be centered over the center windshield retainer. Readjust belt tension on both sides of helicopter until nose belt is centered.

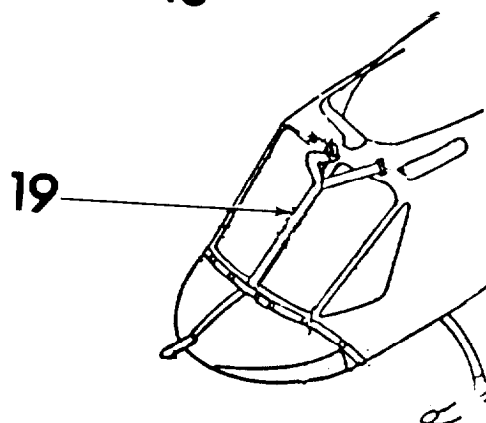

Outside Installation Task 3: Install Nose Belt (Cont).

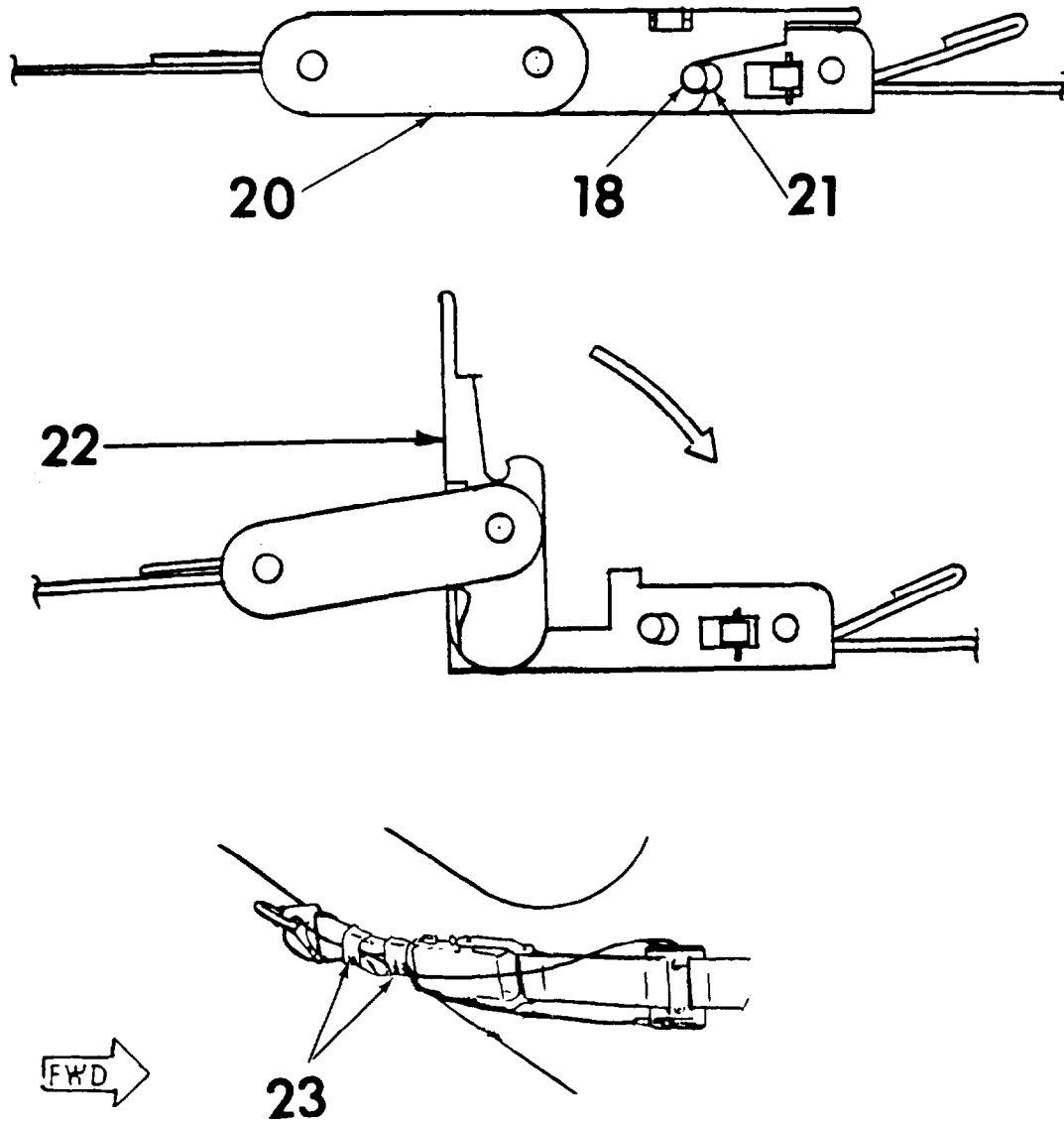

Check that buckles (20) are securely latched. Belt tension release (18) must be locked into detent (21) of nose belt buckle.

Check for proper belt tension. Tension is correct when resistance is encountered when buckles (22) are at right angles.

Tuck running end of belt end assemblies under elastic belt retaining loops (23) of belt end assemblies.

Outside Installation Task 4: Install Rear Harness Assembly. The rear harness assembly must be installed on the helicopter to provide rear mounting points for the top and bottom belts.

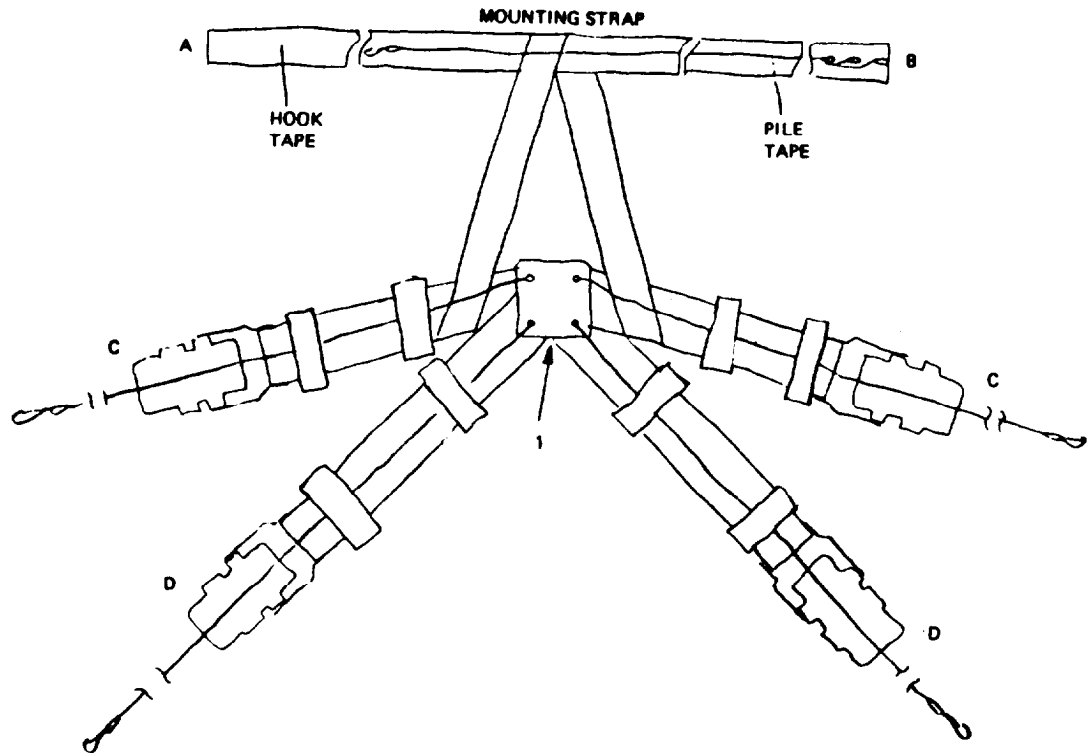

NOTE

Two crewmen are required to install the Rear Harness Assembly.

Outside Installation Task 4: Install Rear Harness Assembly (Cont)

WITHOUT TAIL ROTOR DRIVESHAFT COVER

Crewman 1:

Slide long section of the mounting strap (1) under the driveshaft (2) behind the aft fairing (3) and between the No. 3 driveshaft hanger bearing support bracket (4). Hold the rear harness in place.

Crewman 2:

Grab long section of mounting strap (1). Lay other section (5) of mounting strap against skin of the tailboom (6).

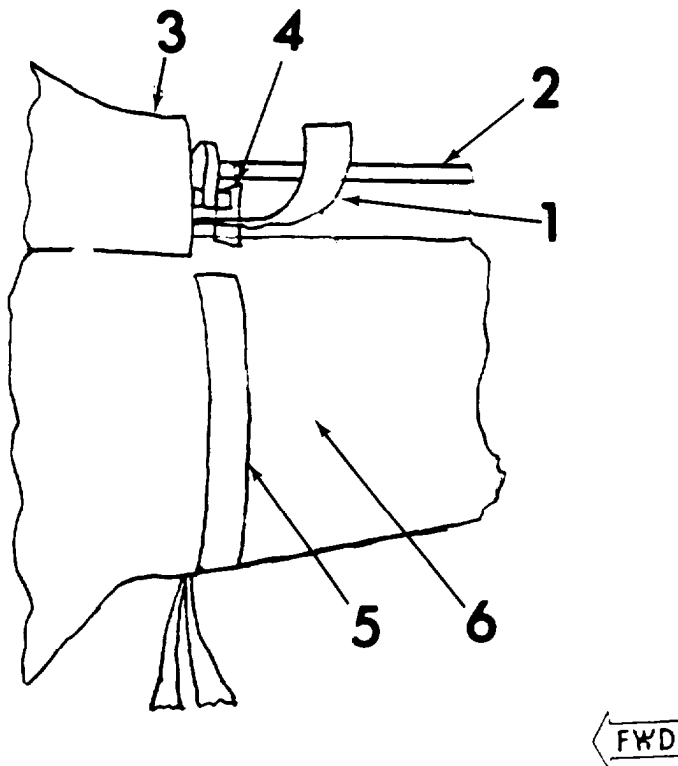

WITH TAIL ROTOR DRIVESHAFT COVER

Crewman 1:

Drop long section of the mounting strap (1) over top of driveshaft cover (7). Hold the rear harness in place.

Crewman 2:

Grab long section of mounting strap (1). Lay other section (5) of mounting strap against skin of tailboom (6).

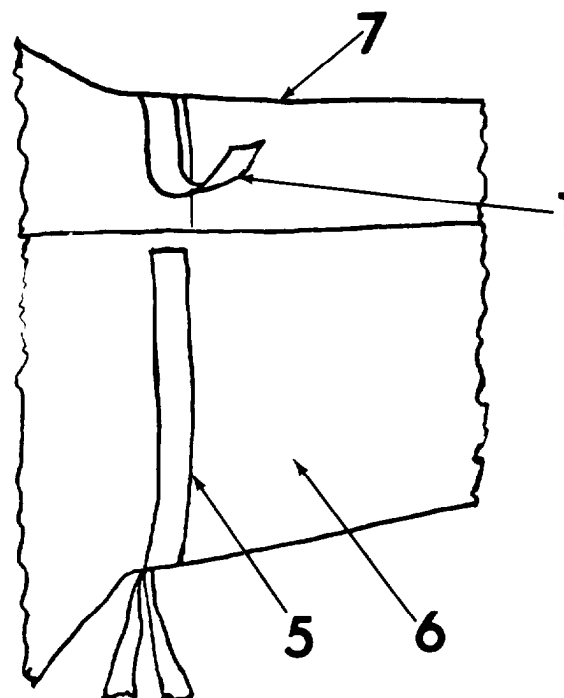

Crewman 1:

Release mounting strap. Adjust rear harness plate (8) position. Rear harness plate should be centered on aft fuselage area. Keep plate centered.

Crewman 2:

Tightly secure the mounting strap (9) by allowing the hook and pile fastener tapes to contact each other. Mounting strap is secured on left side of helicopter.

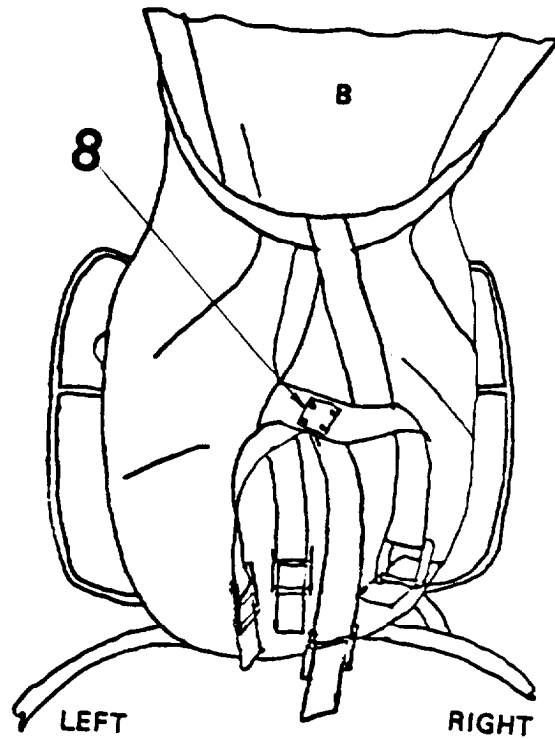

Crewman 1: Release grasp on rear harness plate (8).

Crewman 2: Connect safety lanyard (10) by securing hook of lanyard in eyelet (11) of lanyard. Three eyelets are available. Use eyelet that allows safety lanyard to be the tightest.

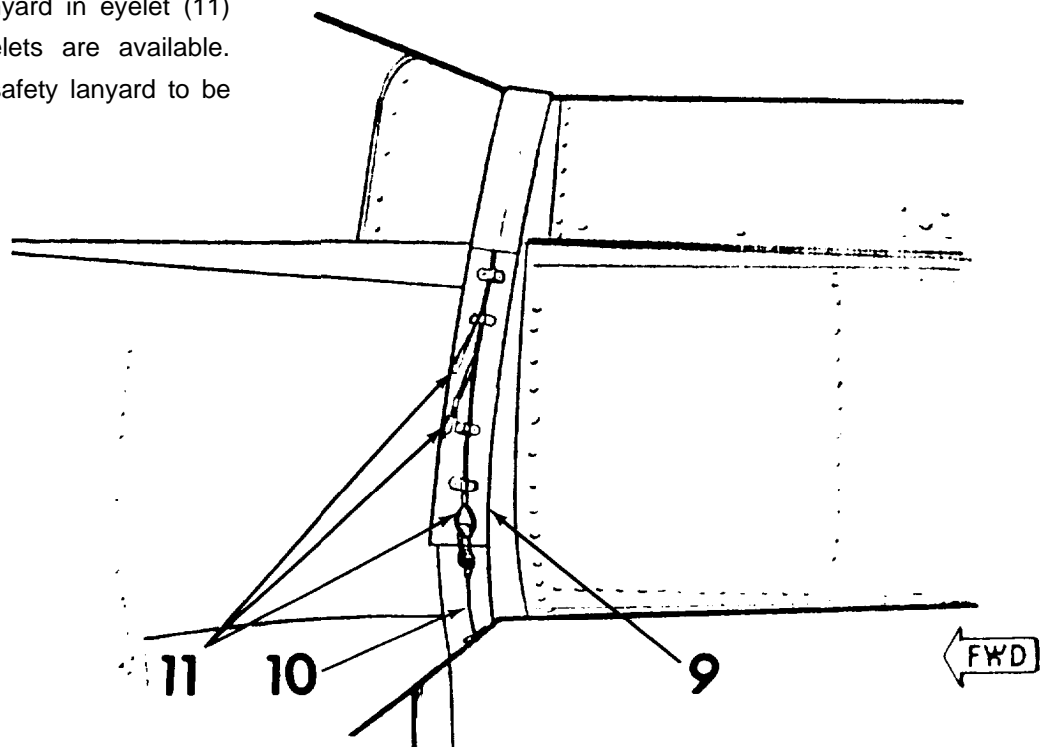

Outside Installation Task 5: Install Top Right Detector Belt. The top right detector belt is installed on the right side of the fuselage above the crew and passenger door windows.

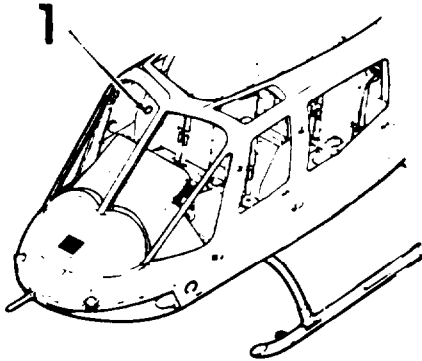

Locate a detector belt labeled Aircraft Segment No. 6.

Remove right D-ring of nose belt from tube of free air temperature gage (1). Attach hook end (2) of the top right belt to this D-ring (3).

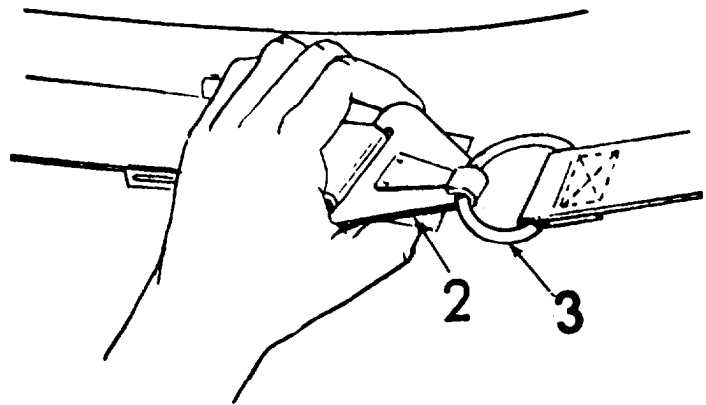

Lay detector belt (4) over fastener tape (5) installed on the upper right fuselage. Protective paper backing (6) should be taped over fastener tape.

Thread lanyard (7) through D-ring and connect it to slot on belt reducer (8).

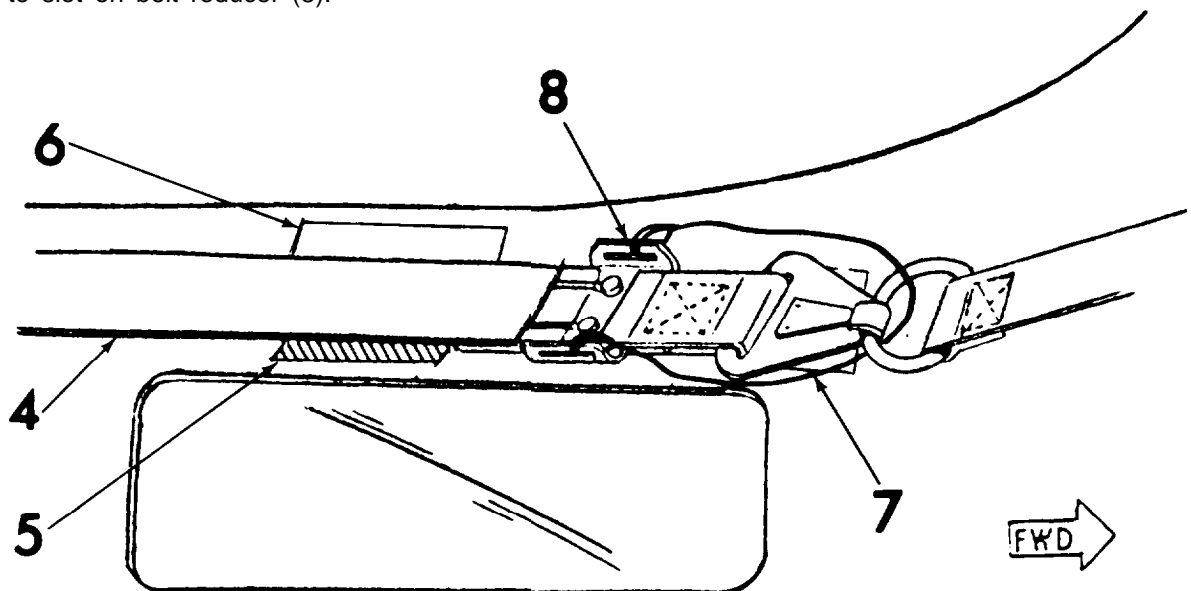

Run the detector belt above the crew and passenger doors (9) and under the upper arm (10) of the FM homing antenna. Continue laying the belt against the fuselage to the rear of the helicopter.

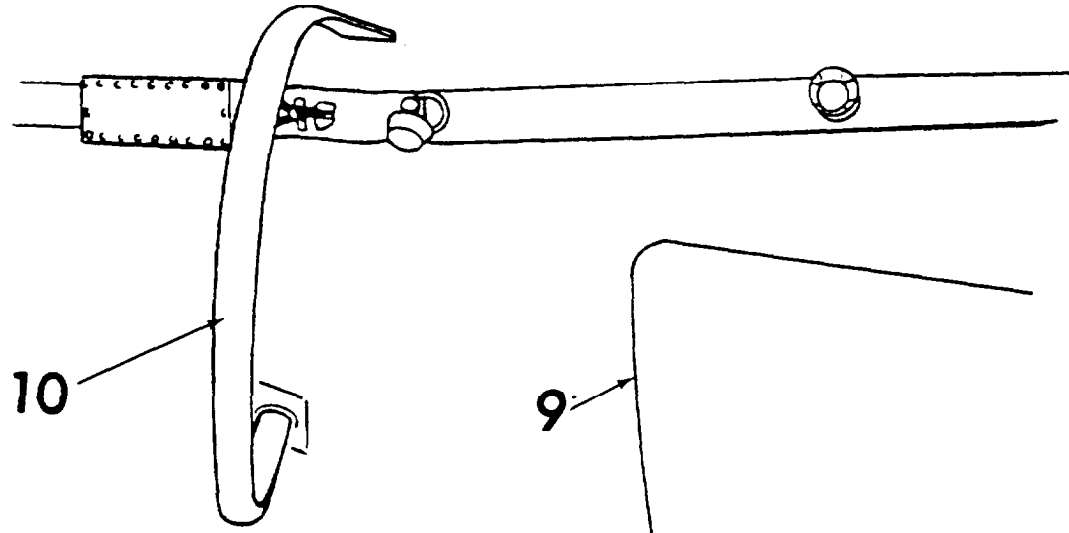

Attach to top right buckle (11) of rear harness assembly.

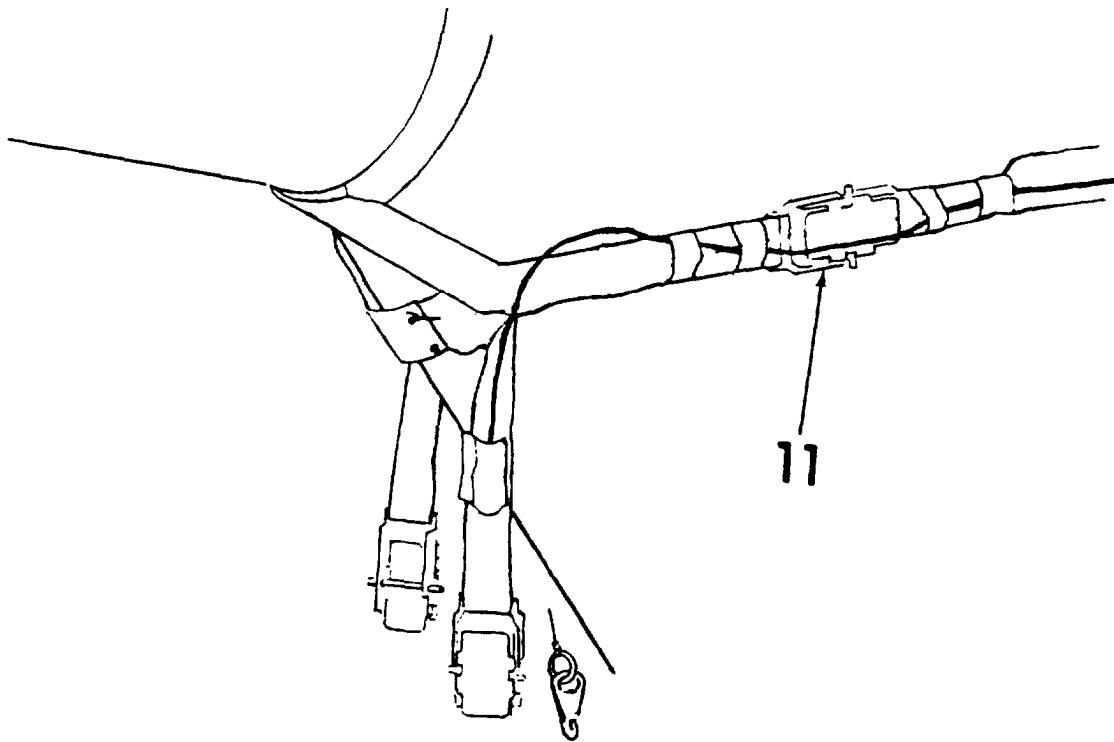

Outside Installation Task 6: Install Top Left Detector Belt. The top left detector belt is installed on the left side of the fuselage above the crew and passenger door windows.

Locate a detector belt labeled Aircraft Segment No. 6.

Attach hook end (1) of top left belt to left D-ring (2) of nose belt. Lay top left belt (3) over fastener tape (4) installed on upper left fuselage. Protective paper backing (5) should still be taped over fastener tape.

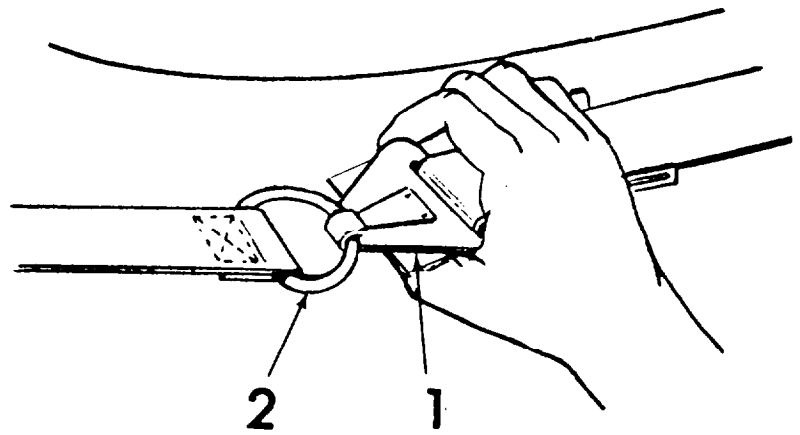

Thread lanyard (6) through D-ring and connect it to slot on belt reducer (7).

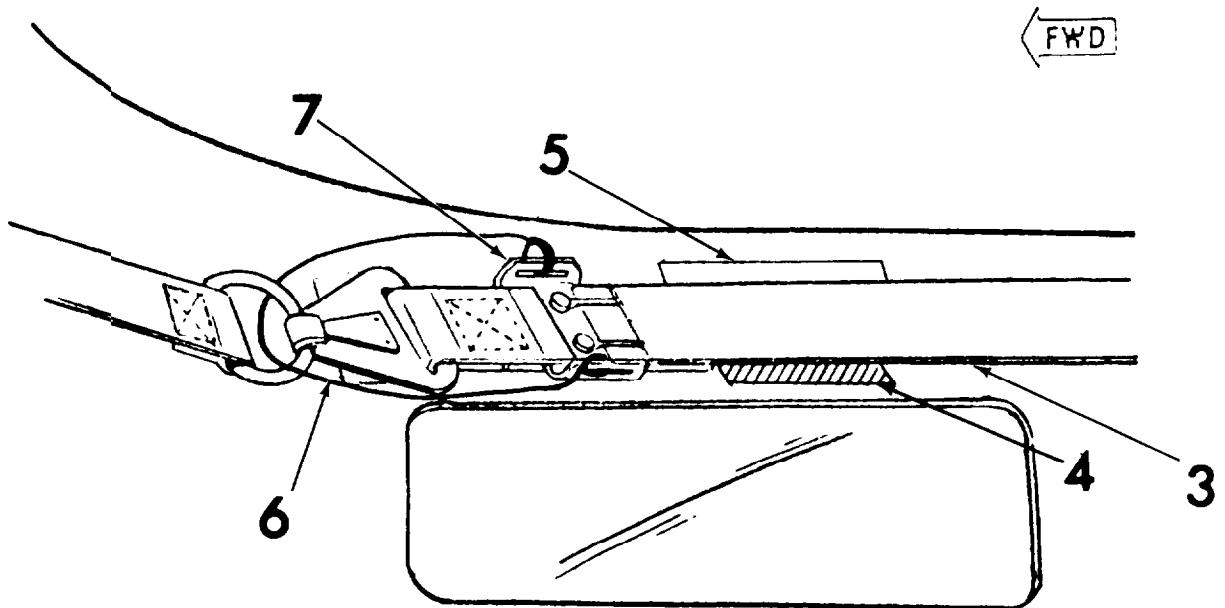

Run detector belt above crew and passenger doors (8) and under the upper arm (9) of the FM homing antenna. Continue laying belt against fuselage to rear of helicopter.

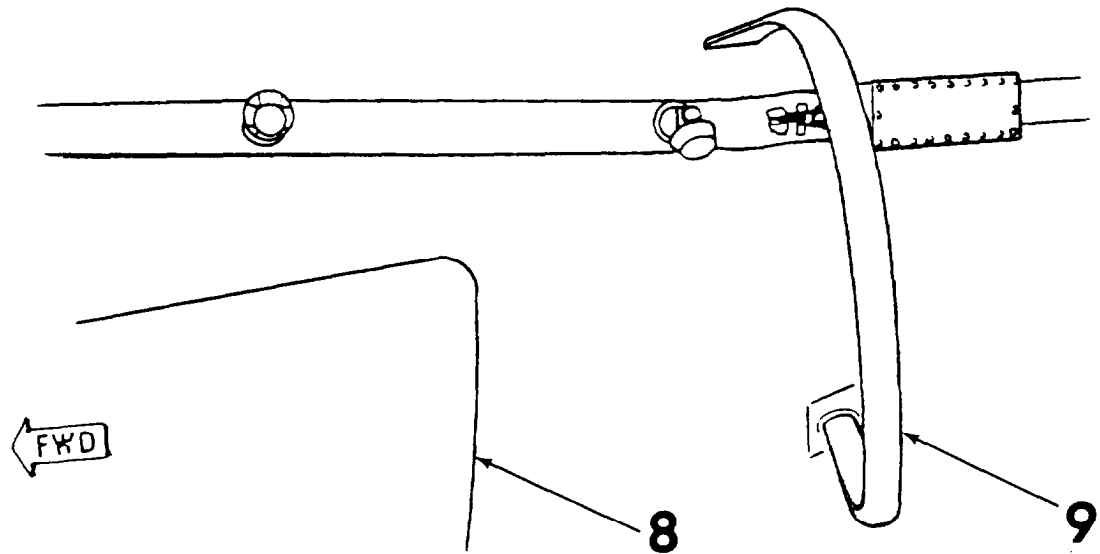

Attach to top left buckle (10) of rear harness assembly.

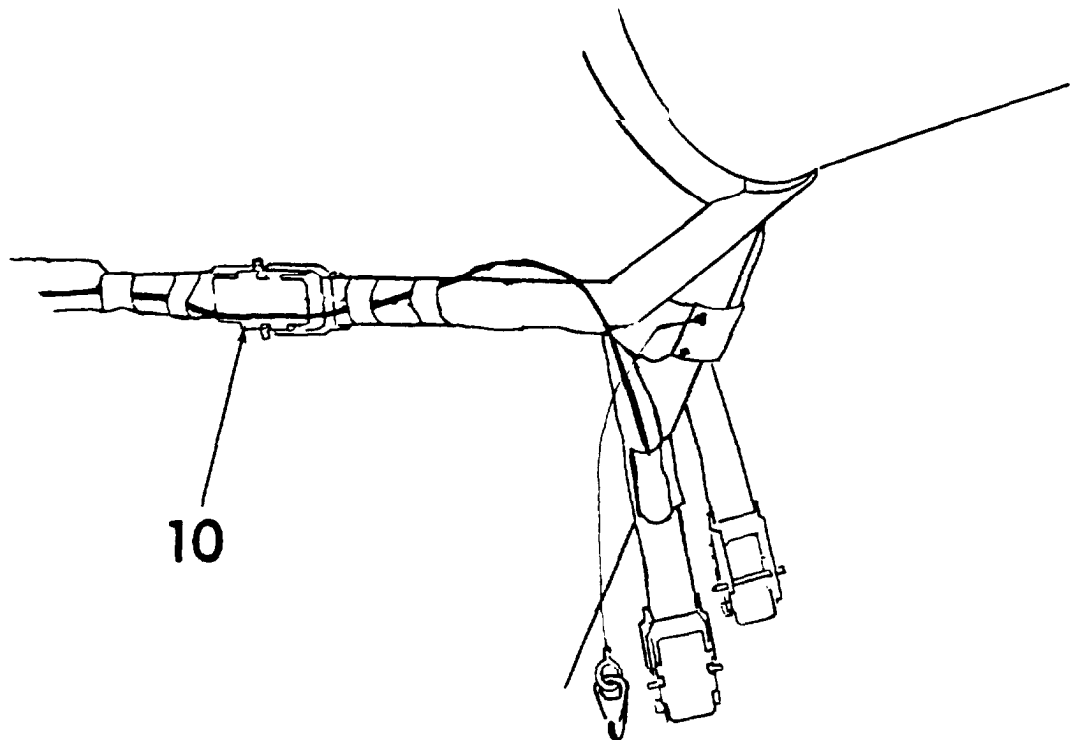

Outside Installation Task 7: Install Bottom Right Detector Belt.

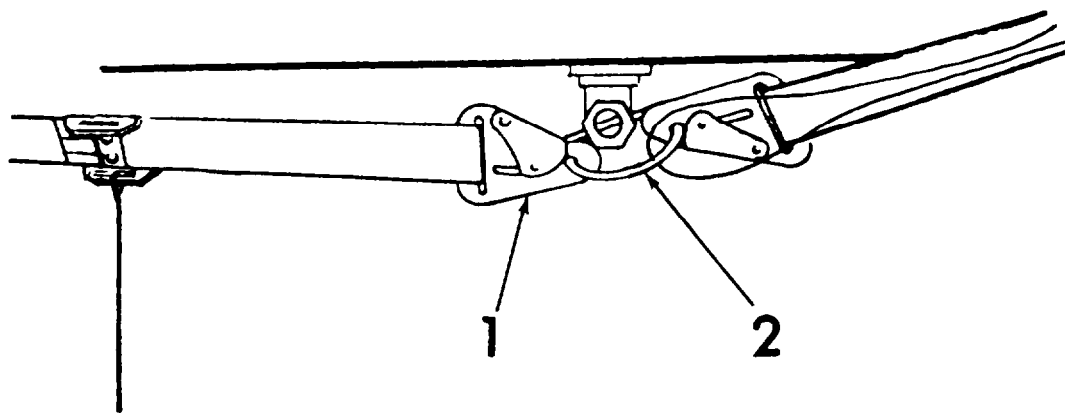

Locate a detector belt labeled Aircraft Segment No. 5. Attach hook end (1) of detector belt to ring assembly (2) on lower right fuselage.

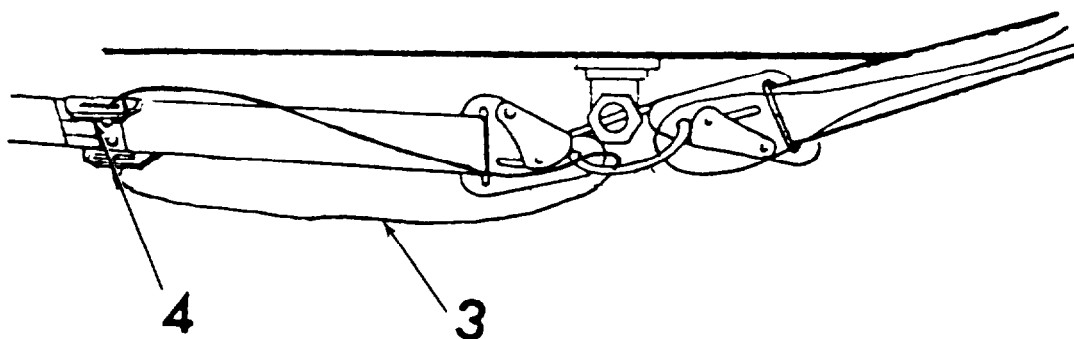

Thread lanyard (3) through ring assembly and attach to slot on belt reducer (4).

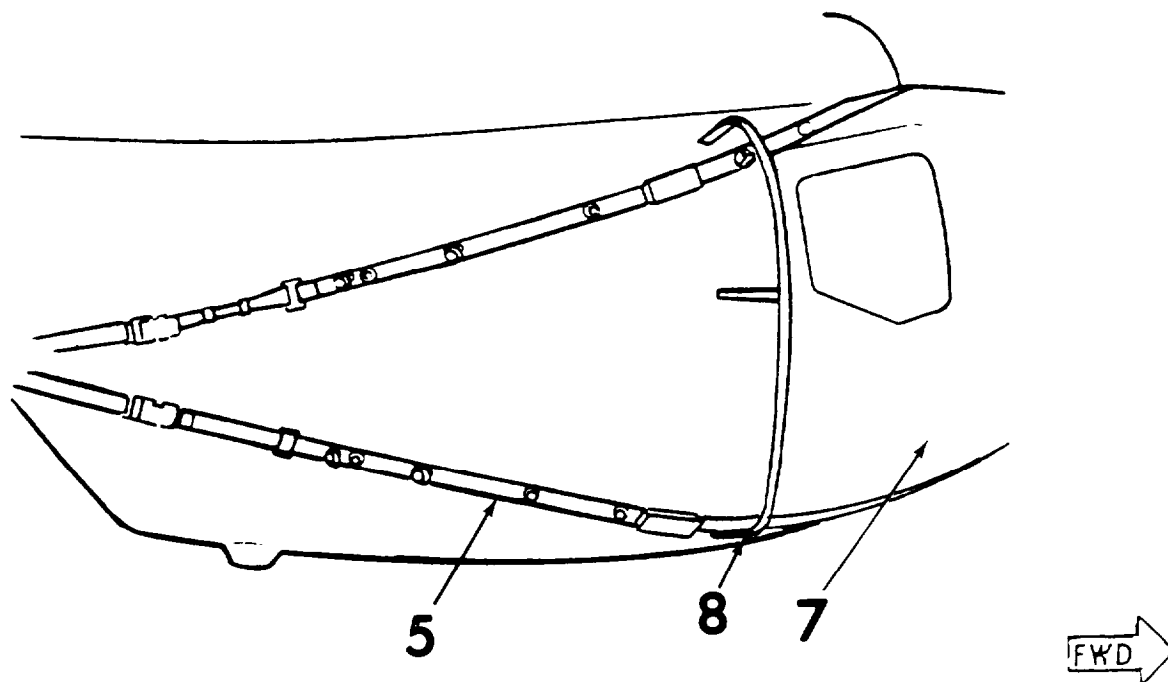

Run belt (5) below crew (6) and passenger doors (7) and above lower arm (8) of FM homing antenna. Continue laying belt against fuselage to helicopter rear.

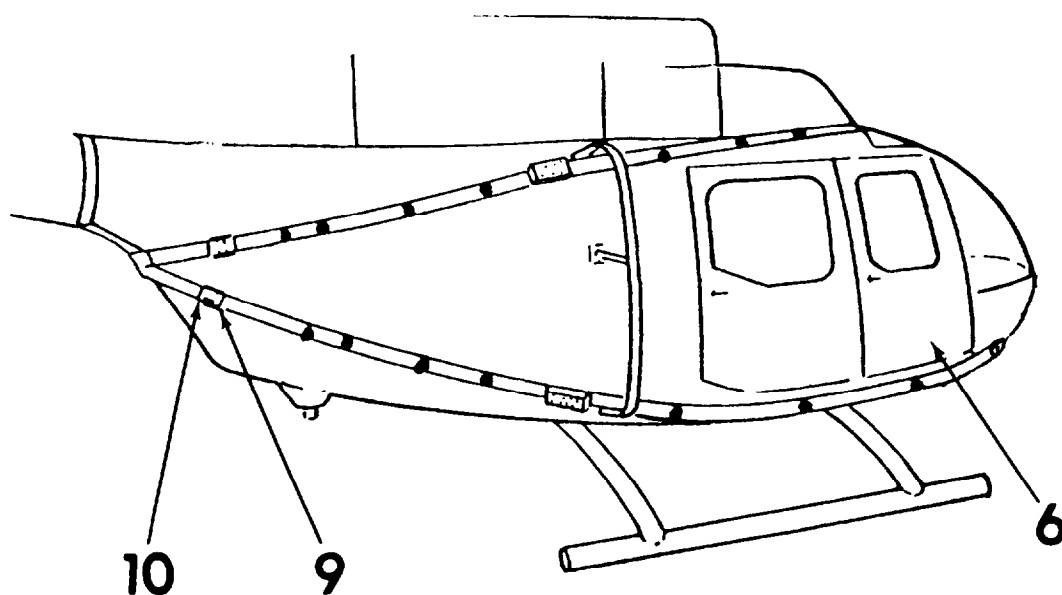

Attach detector belt buckle (9) to lower right buckle (10) of rear harness assembly.

Outside installation Task 8: install Bottom Left Detector Belt. The bottom right detector belt is installed below the access doors.

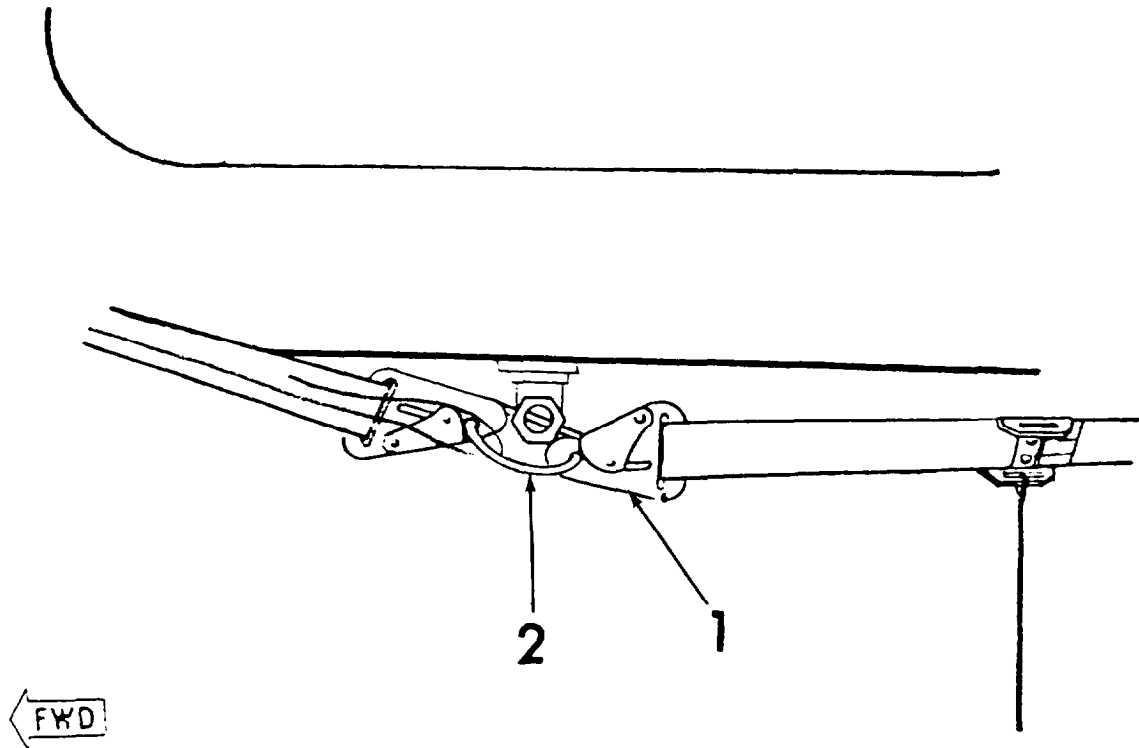

Locate a detector belt labeled Aircraft Segment No. 5. Attach hook end (1) of detector belt to ring assembly (2) on lower left fuselage.

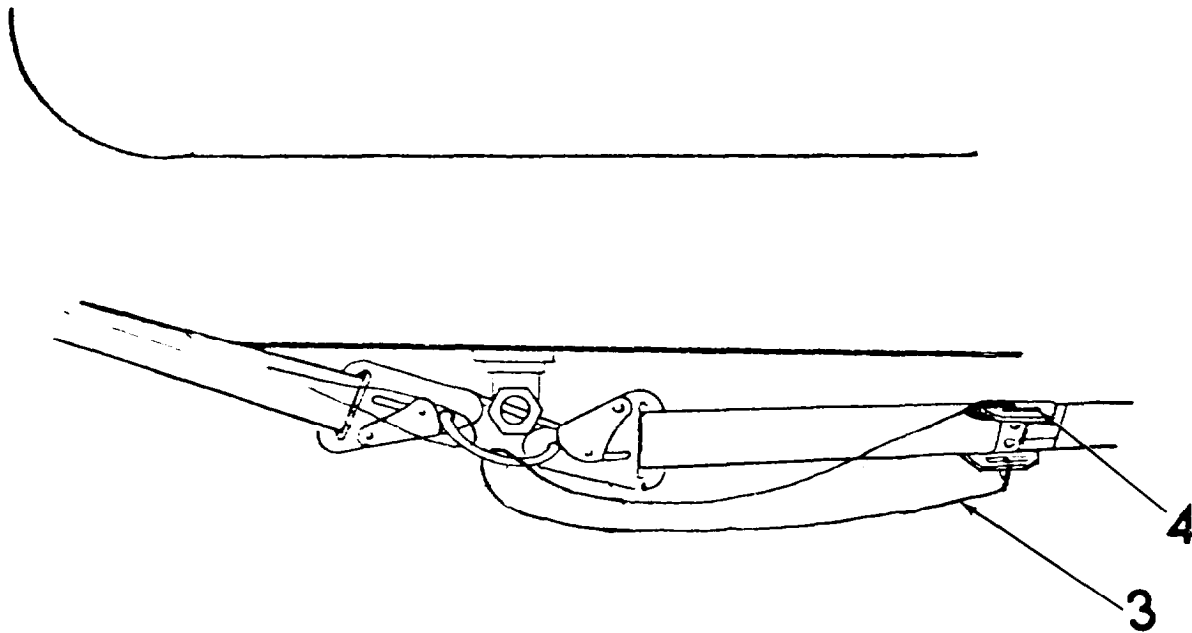

Thread lanyard (3) through ring assembly and attach to slot on belt reducer (4).

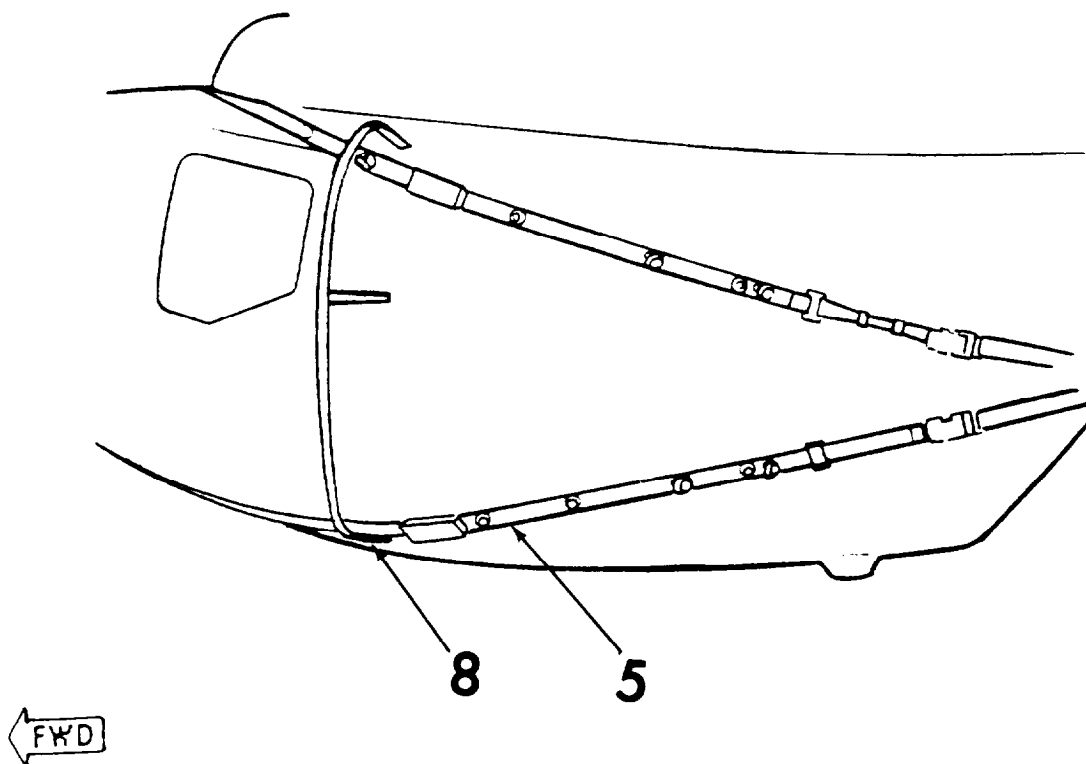

Run bottom belt (5) below crew (6) and passenger doors (7) and above lower arm (8) of FM homing antenna. Continue laying bottom belt against fuselage to helicopter rear.

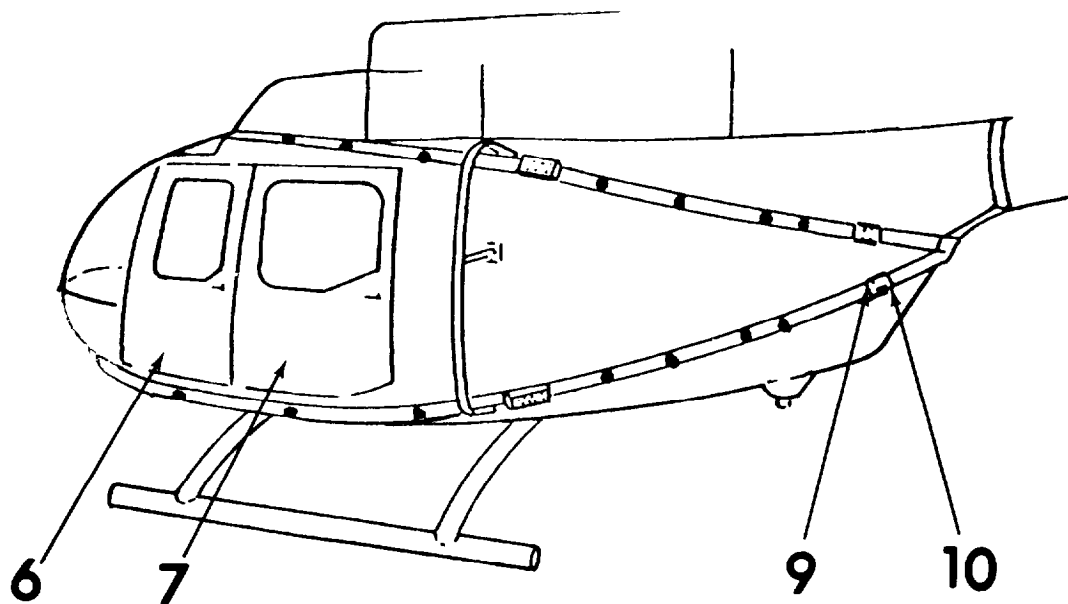

Attach bottom belt buckle (9) to lower left buckle (10) of rear harness assembly.

Outside Installation Task 9: Adjust Side Detector Belts

NOTE

This task will require two crewmen, one on each side of the helicopter at the rear harness assembly.

Check that all fastener tape flaps (1) on lower belts are spread out

With buckle at right angle (4), adjust tension in the two top belts so belts are snug but not tight.

To tighten belt, pull running end (2) of side detector belt. To loosen belt, push belt tension release (3) toward rear harness assembly.

Tension is correct when resistance is encountered with buckle at right angle (4) to belt.

With buckle at right angle (4), adjust tension in the two bottom belts so belts are snug but not tight,

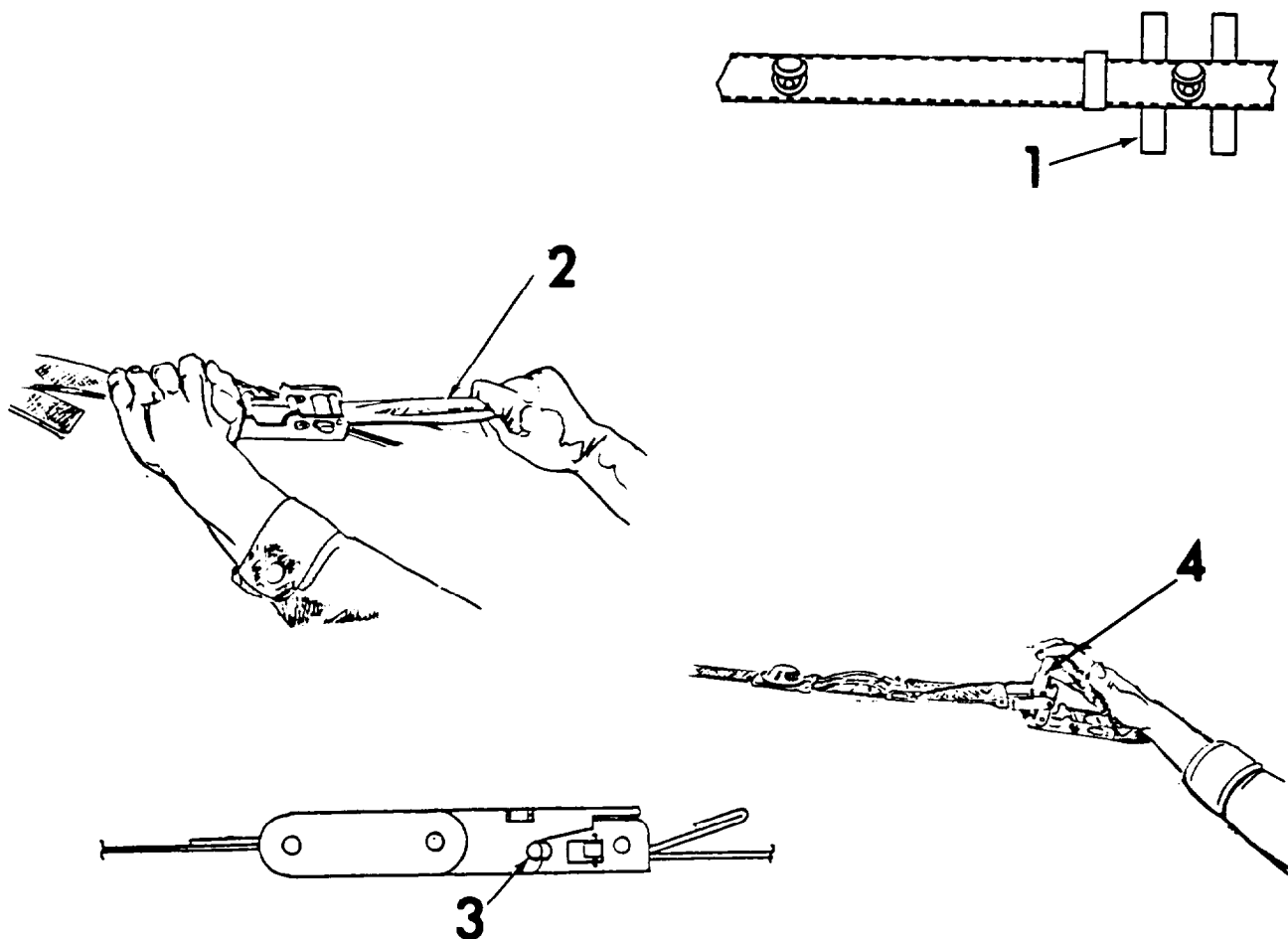

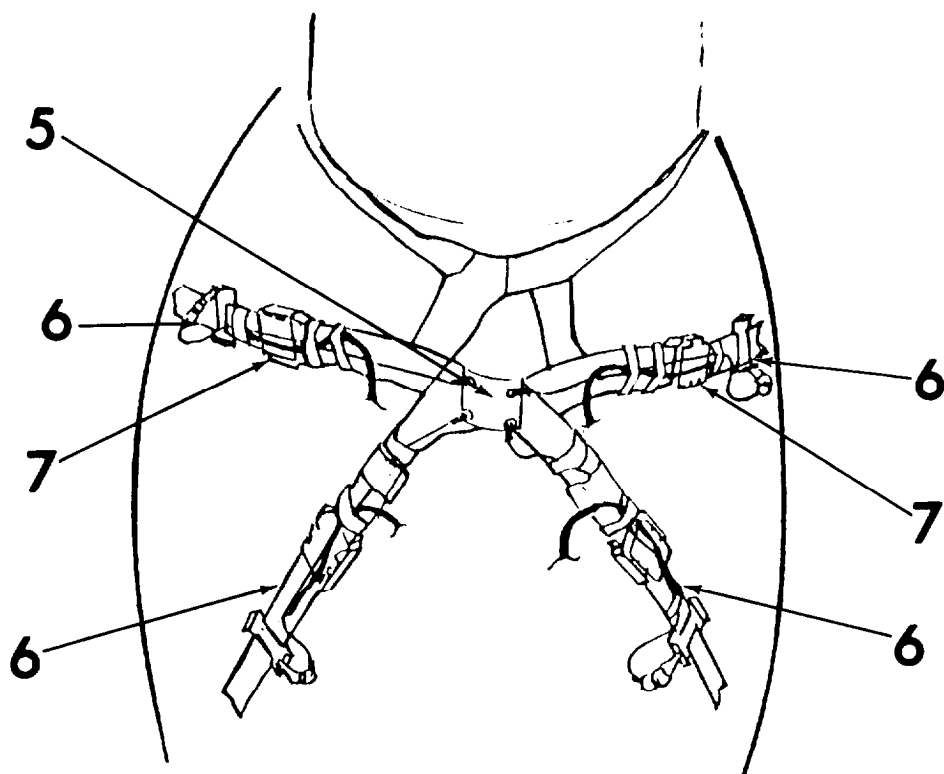

Check alignment of rear harness plate (5). Plate should still be centered on aft fuselage area. If necessary, adjust tension in belts (6) so that rear harness plate is centered.

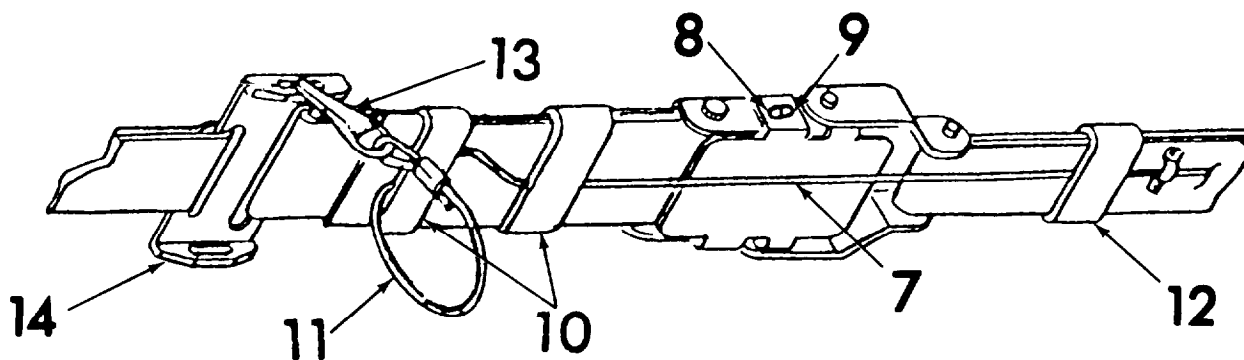

Latch the two top buckles (7) at the same time. Buckle releases (8) must be locked into detents (9) of rear harness assembly buckles.

Tuck running ends of top belts under elastic belt retaining loops (10) of top belts.

Run the rear harness assembly top safety lanyards (11) through harness elastic loops (12) and retaining loops (10). Clip safety lanyard free end (13) to slot on top belt reducers (14).

Outside Installation Task 9: Adjust Side Detector Belts (Cont).

Latch the two bottom buckles (15) at the same time. Buckle releases (16) must be locked into detents (17) of rear harness assembly buckle.

Tuck running ends (18) of bottom belts under elastic belt retaining loops (19) of bottom belts.

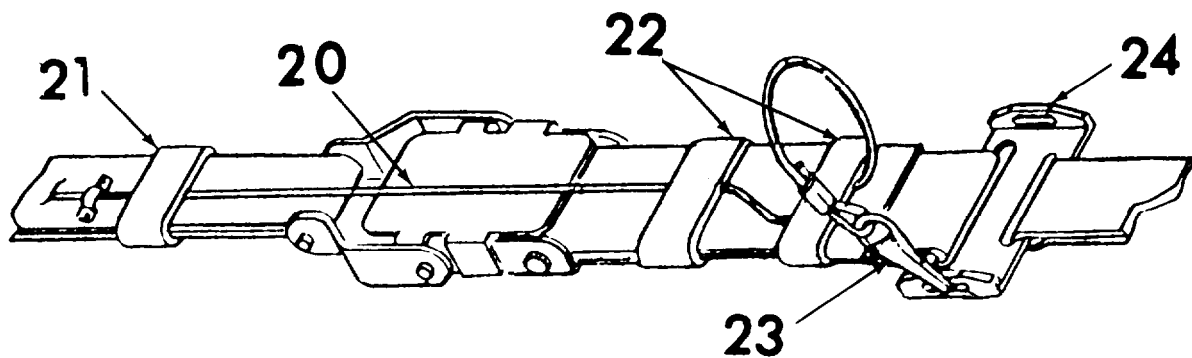
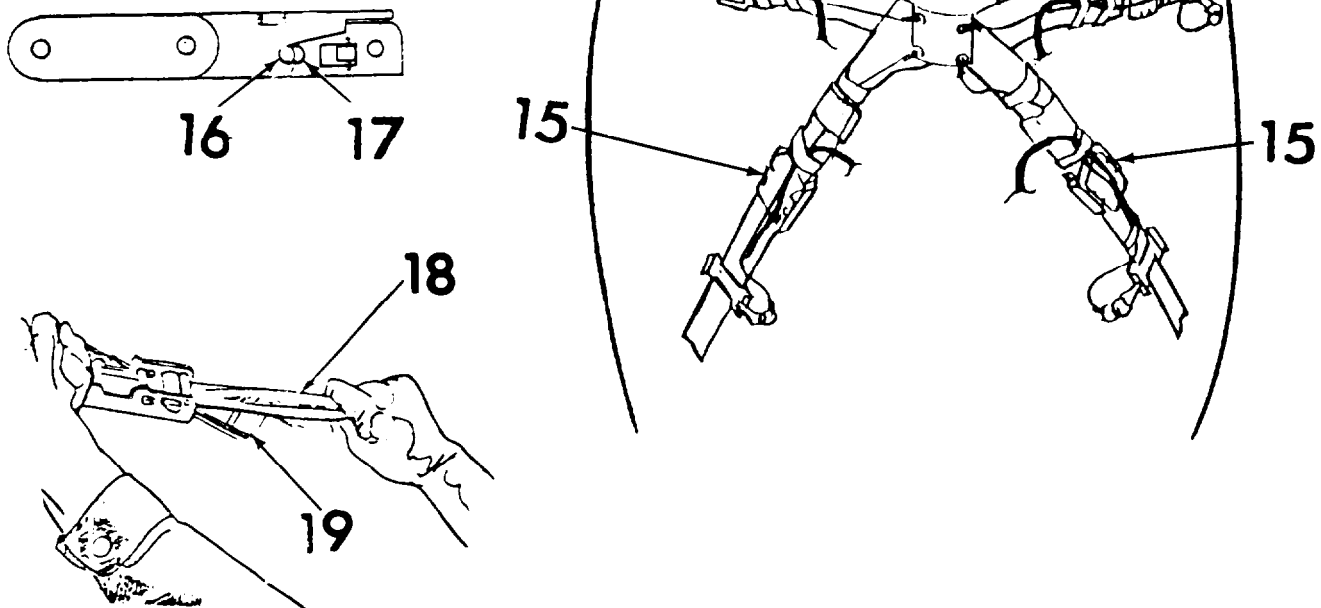

Run the rear harness assembly bottom safety lanyards (20) through harness elastic loops (21) and bottom belt elastic loops (22). Clip safety lanyard free end (23) to slot on belt reducers (24).

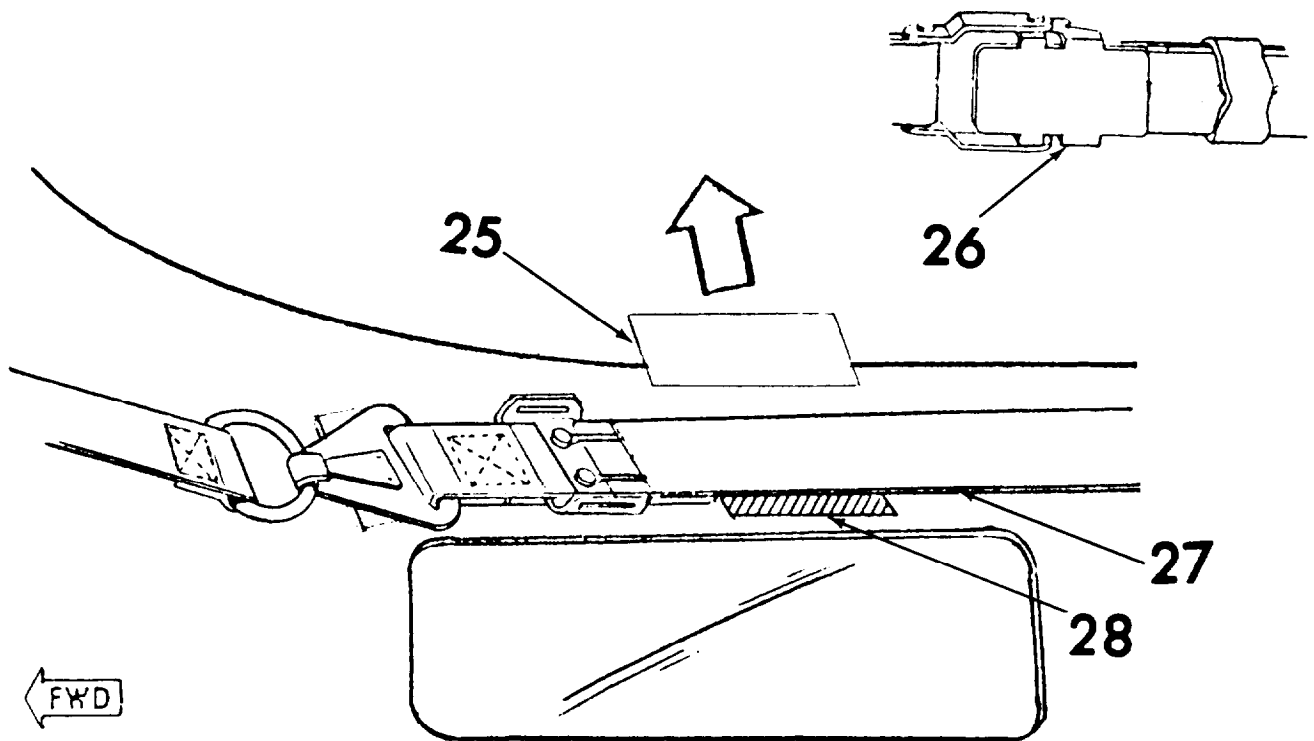

Remove protective paper backing (25) that was taped over fastener tape on upper front fuselage. Remove paper from both sides of helicopter. Temporarily loosen buckle (26), if necessary, to remove tape. Press top belt (27) against fastener tape (28) that is adhered to upper front fuselage. Do this step to both sides of helicopter.

Outside Installation Task 10: Mate Side Detector Belt Connectors.

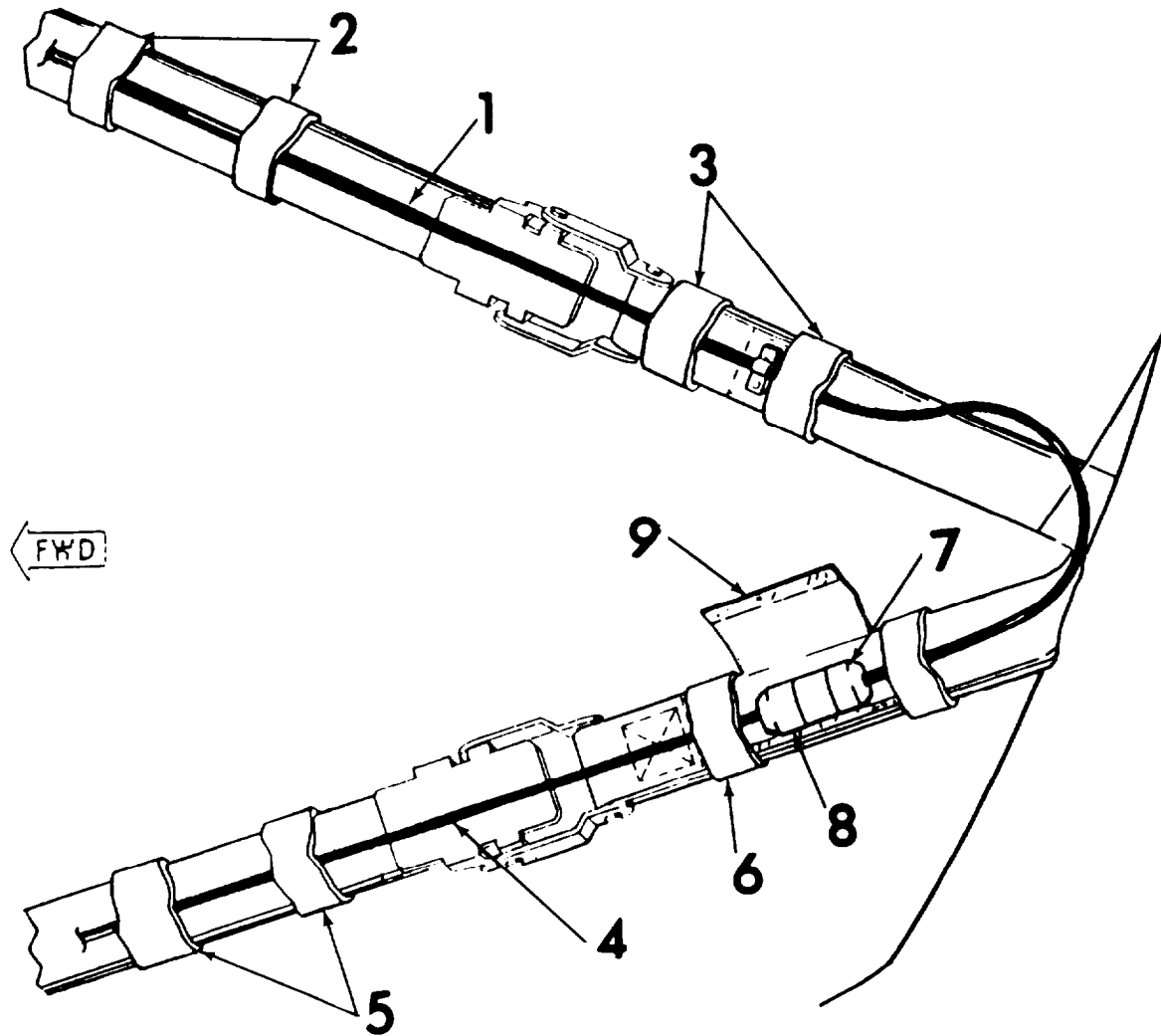

Run top belt cable (1) under top belt elastic belt retainer loops (2) and under rear harness assembly elastic belt retainer loops (3).

Run bottom belt cable (4) under bottom belt elastic belt retainer loops (5) and under rear harness assembly elastic belt retainer loops (6).

Mate top belt connector P1 (7) to bottom belt connector P2 (8).

Fold flap (9) over mated connectors (7, 8). Secure flap with attached fastener tape.

Mate belt connectors on opposite side of helicopter using identical procedure.

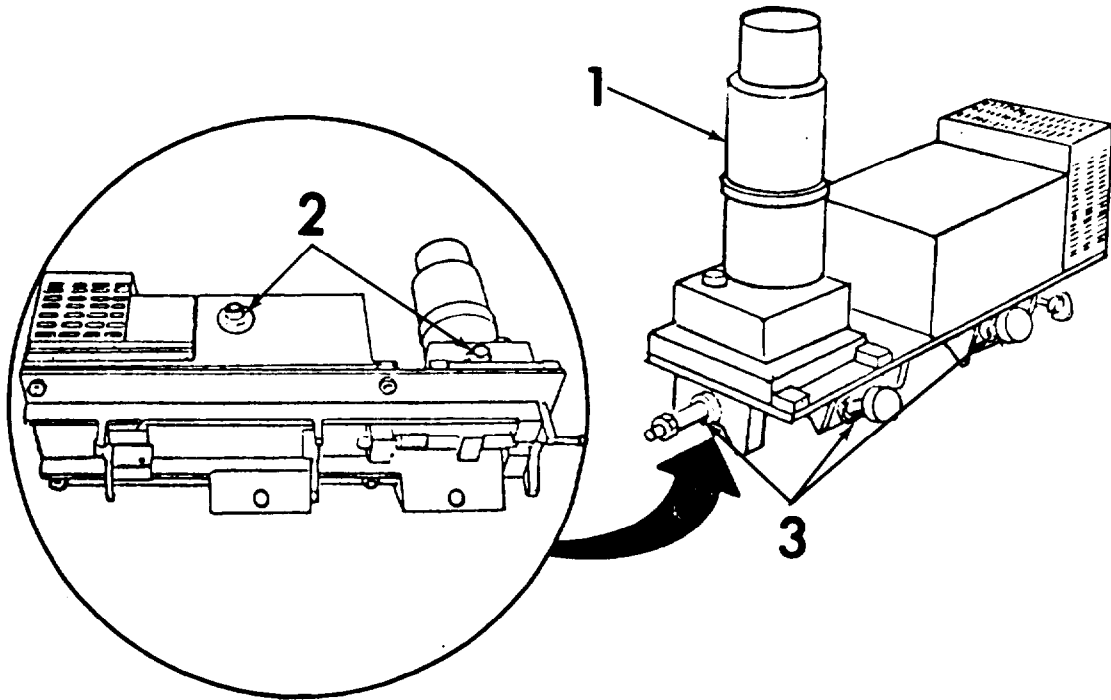
Outside Installation Task 11: Inspect AKI/Smoke indicator Assembly.

Inspect Aircraft Kill Indicator and Smoke Indicator Assembly for any damage that would prevent installation or operation.

Check for cracks in plastic lens (1).

Check for damaged receptacles (2).

Check for damage to mounting bracket threads (3).

Report any damage on DA Form 2402. Replace assembly only if not operable.

Outside Installation Task 12: Install AKI/Smoke Indicator Assembly. The AKI/Smoke mounts to the left skid at the same place where the ground handling equipment attaches to the helicopter.

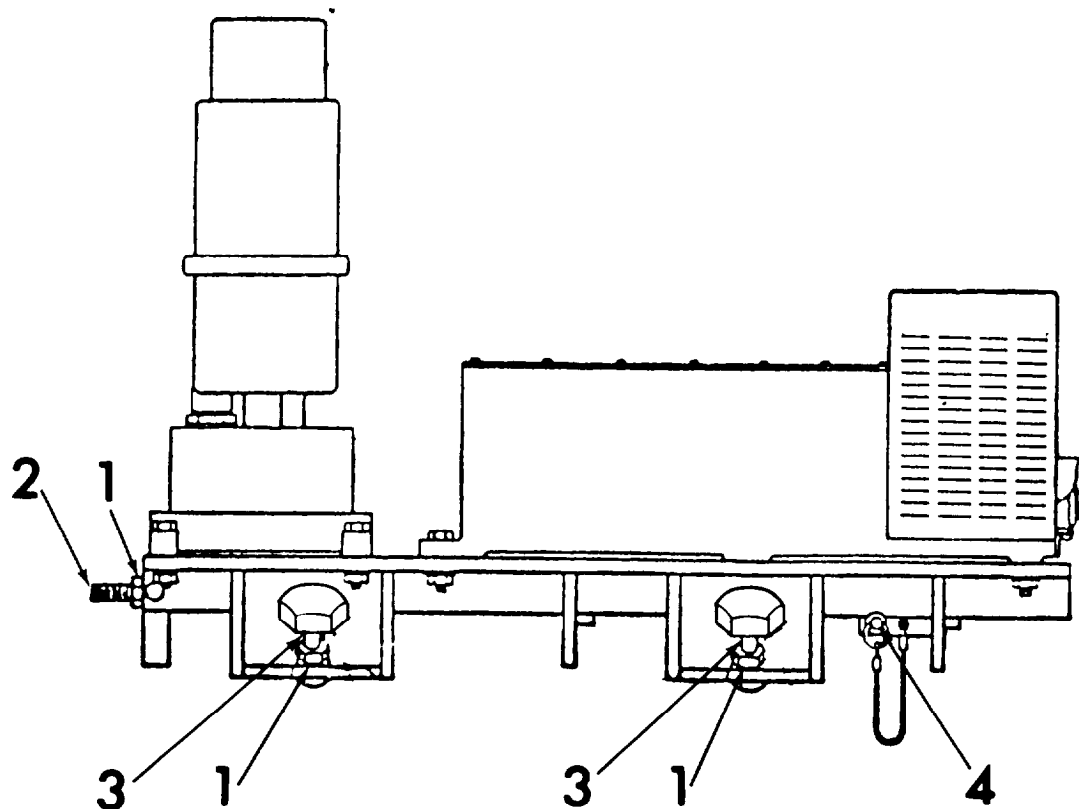

Loosen three jam nuts (1).

Unscrew front swivel screw (2).

Unscrew two side swivel screws (3).

Depress quick release pin center plunger (4). Grasp pin assembly head and remove pin.

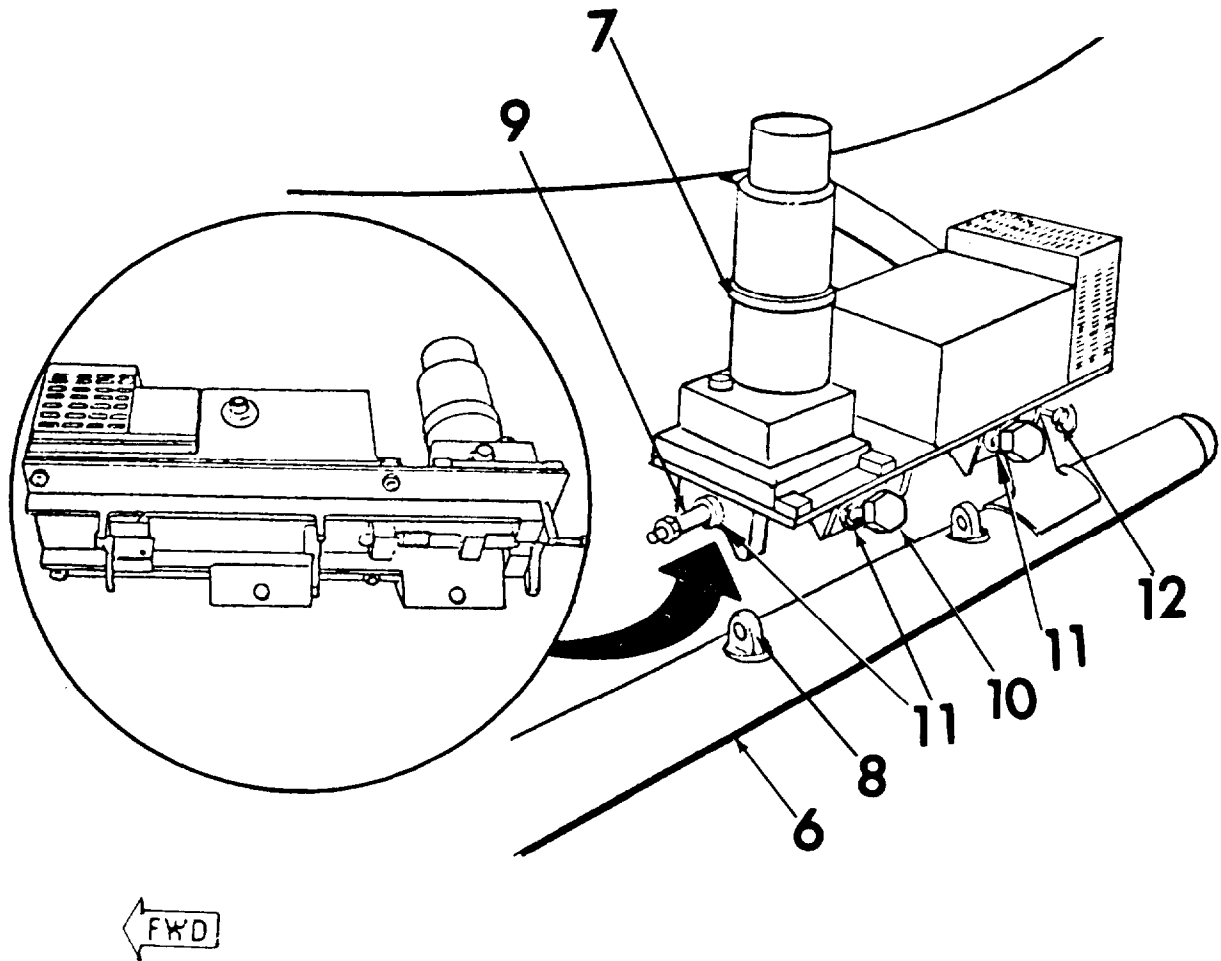

Place AKI/Smoke Indicator Assembly on left skid tube (6) with AKI (7) to front. Tilt AKI/Smoke Indicator Assembly slightly towards helicopter.

Slide AKI/Smoke Indicator Assembly forward until skid tube fitting arms (8) are firmly seated in mounting holes on base of AKI/Smoke Indicator Assembly.

Tighten front swivel screw (9).

Hand tighten two side swivel screws (10).

Tighten three jam nuts (11).

Insert quick release pin (12) into its mounting hole. Ensure that pin is completely seated.

INSIDE INSTALLATION TASKS - LIST

<u>Task</u>	<u>Title</u>	<u>Page</u>
1.	Obtain Equipment	2-40
2.	Inspect Battery Box/ACIA Assembly	2-41
3.	Install Battery Box/ACIA Assembly	2-42
4.	Inspect Cockpit Kill Indicator (CKI) Assembly	2-43
5.	Install Cockpit Kill Indicator (CKI) Assembly	2-44

Inside Installation Task 1: Obtain Equipment Completion of Inside Installation Tasks requires equipment listed and illustrated below. Locate and set aside this equipment.

1 Battery Box/ACIA Assembly (1)

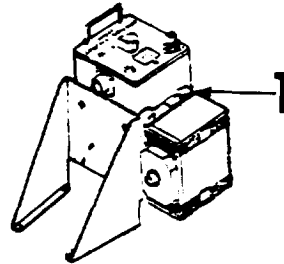

1 Cockpit kill Indicator (2)

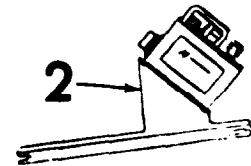

1 Cockpit Kill Indicator Adapter (3)

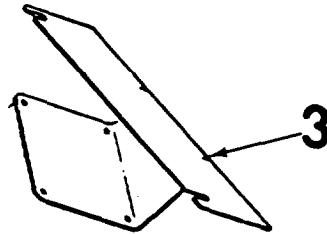

Inside Installation Task 2: Inspect Battery Box/ACIA Assembly.

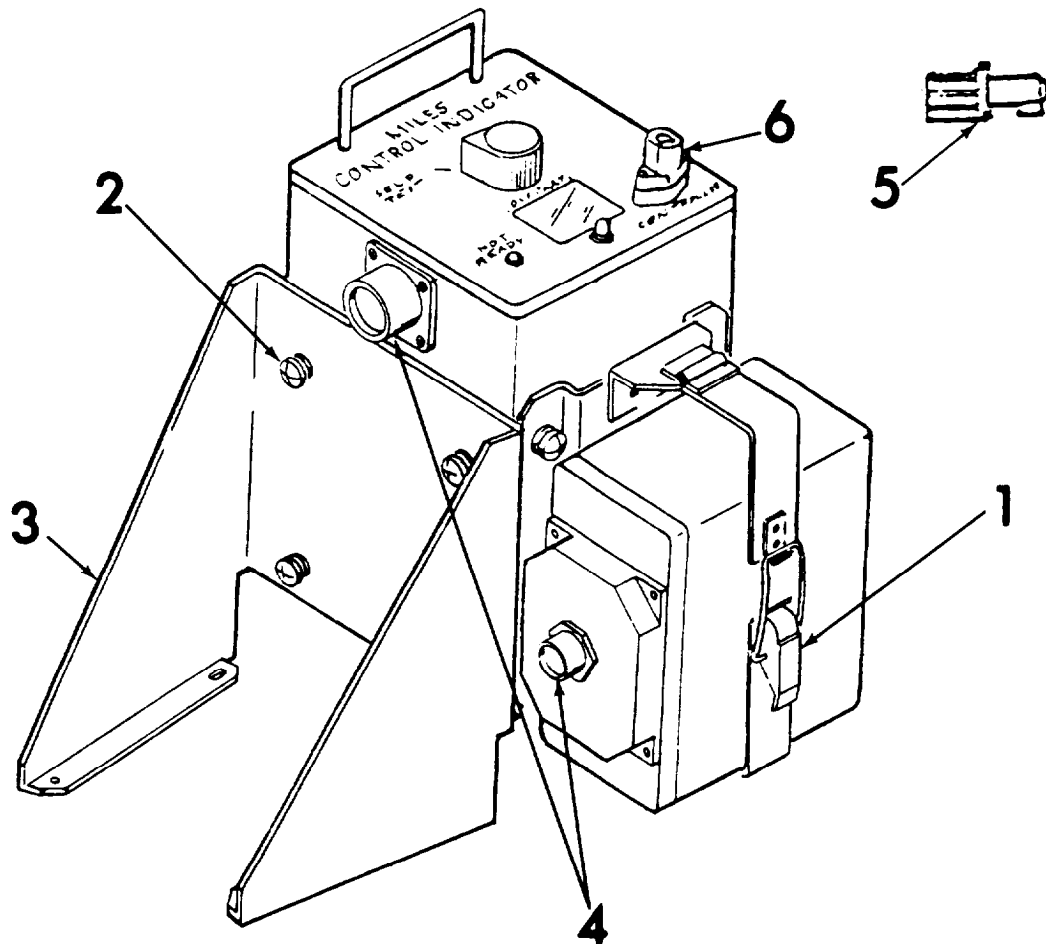

Inspect Battery Box/ACIA Assembly for any damage that would prevent normal operation or installation.

Ensure battery box fastener (1) is securely latched.

Ensure screws (2) securing mounting bracket (3) to ACIA are snug. Check for damaged connectors (4). Check that weapon key (5) turns freely in key receptacle (6). Weapon key is provided by a Controller.

Report any damage on DA Form 2404. Replace assembly only if not operable.

Inside Installation Task 3: Install Battery Box/ACIA Assembly. The Battery Box/ACIA is mounted in the center of the passenger compartment floor, between the center post and passenger seat,

Unlatch and swing open lid (1) of battery box (2).

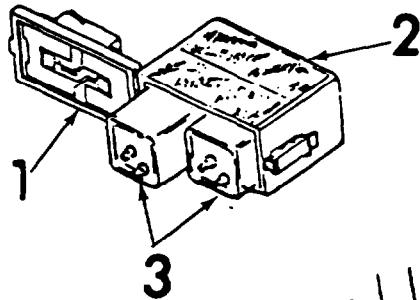

Insert two 6 V batteries (3) (Item 1, Section III, Appendix D) into battery box with battery contacts facing forward.

Close and latch lid of battery box.

Remove two forward and two center screws (4) and flat washers (5) securing cover (6) to cargo platform.

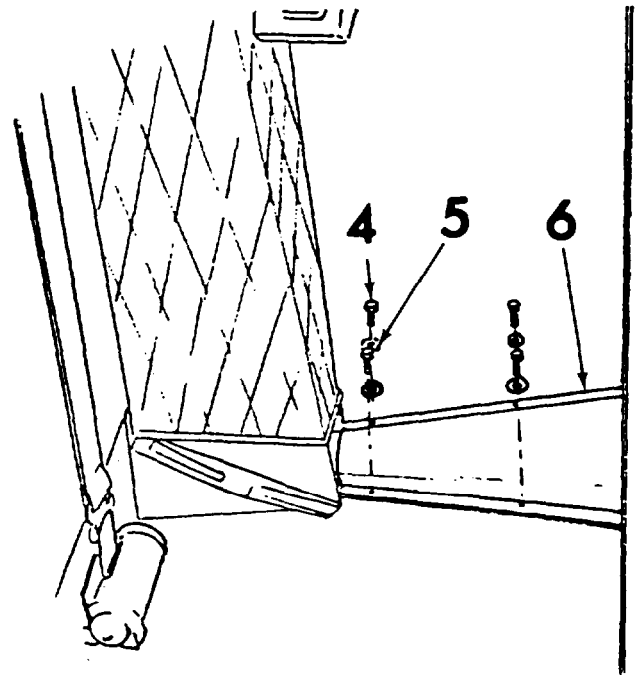

Place Battery Box/ACIA Assembly (7) on passenger compartment floor with mounting bracket (8) to front and battery box (2) to left. Align four holes in mounting bracket with four screw holes in middle of cargo platform. Secure Battery Box/ACIA by installing original screws (4) and flat washers (5).

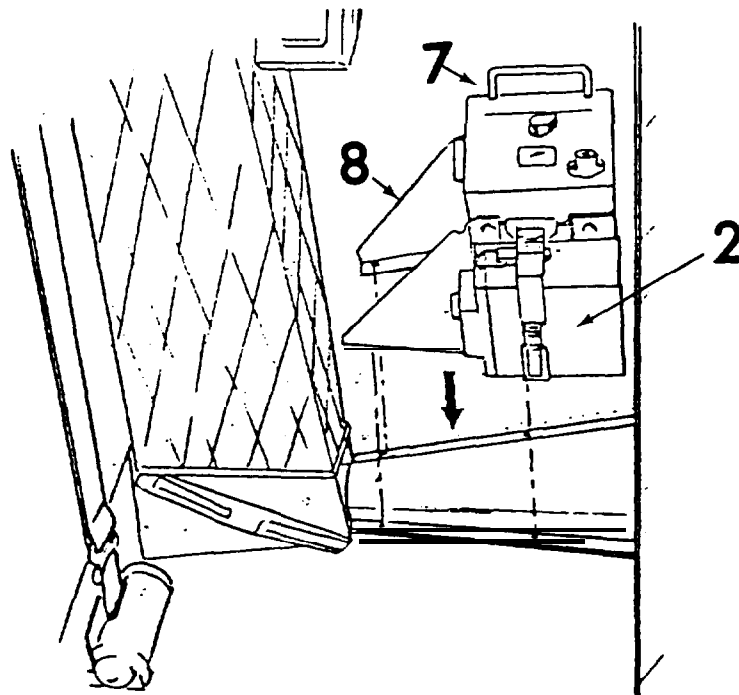

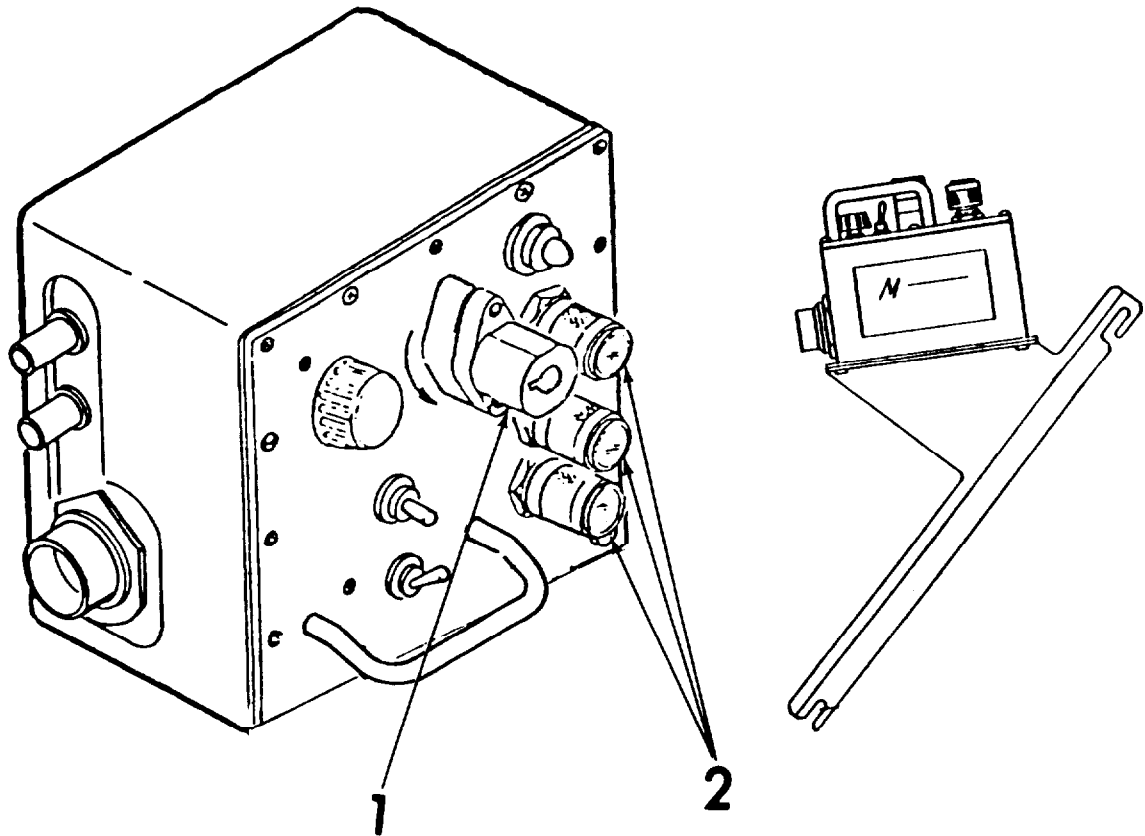
Inside Installation Task 4: Inspect Cockpit Kill Indicator (CKI) Assembly.

inspect Cockpit Kill Indicator for damage that would prevent normal operation or installation.

Check that controller key turns freely in key receptacle (1). Controller key is provided by a Controller.

Insure that irises on warning lamps (2) operate properly.

Report any damage on DA form 2404. Replace CKI only if not operable.

Inside Installation Task 5: Install Cockpit Kill Indicator (CKI) Assembly.

CKI is mounted on the center windshield retainer just above the instrument panel.

OH - 58A MODELS

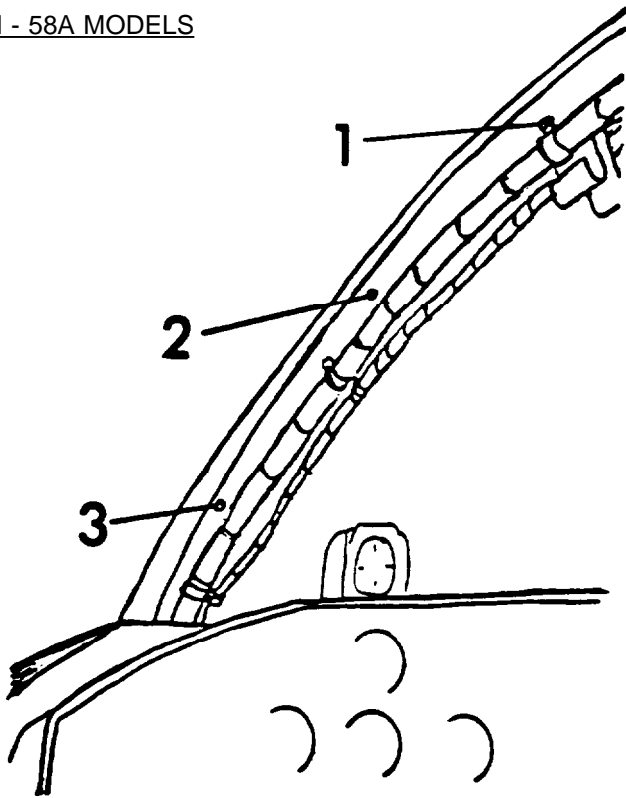

If the helicopter has an AN/APR-39 Radar Warning Set installed, loosen but do not remove upper screws and nuts (1, 2).

If helicopter has no AN/APR-39, loosen but do not remove lower screws and nuts (2,3).

Mount CKI (4) by engaging bottom mounting slot (5) between center windshield retainer (6) and lowest previously loosened screw. Pivot CKI and bracket upwards and engage top mounting slot (7) with other loosened screw. Tighten two screws and nuts on center windshield retainer.

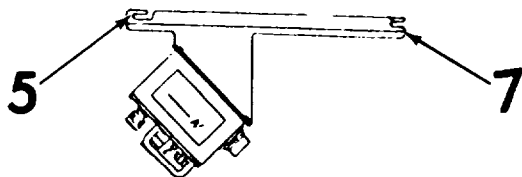
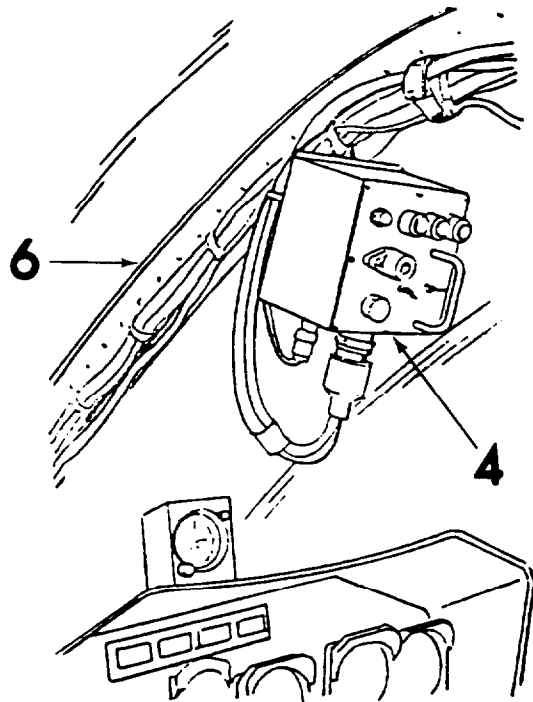

Inside Installation Task 5: Install Cockpit Kill Indicator (CKI) Assembly (Cont).

OH - 58C MODELS

Remove four screws (8) from rear of CKI (9). Remove OH-58A mounting plate (10).

Position OH-58C adapter plate (11) on back of CKI and replace and tighten screws. Store original plate for use following completion of MILES exercises,

Install CKI on windshield retainer of OH-58C using procedures for OH-58A, page 2-44

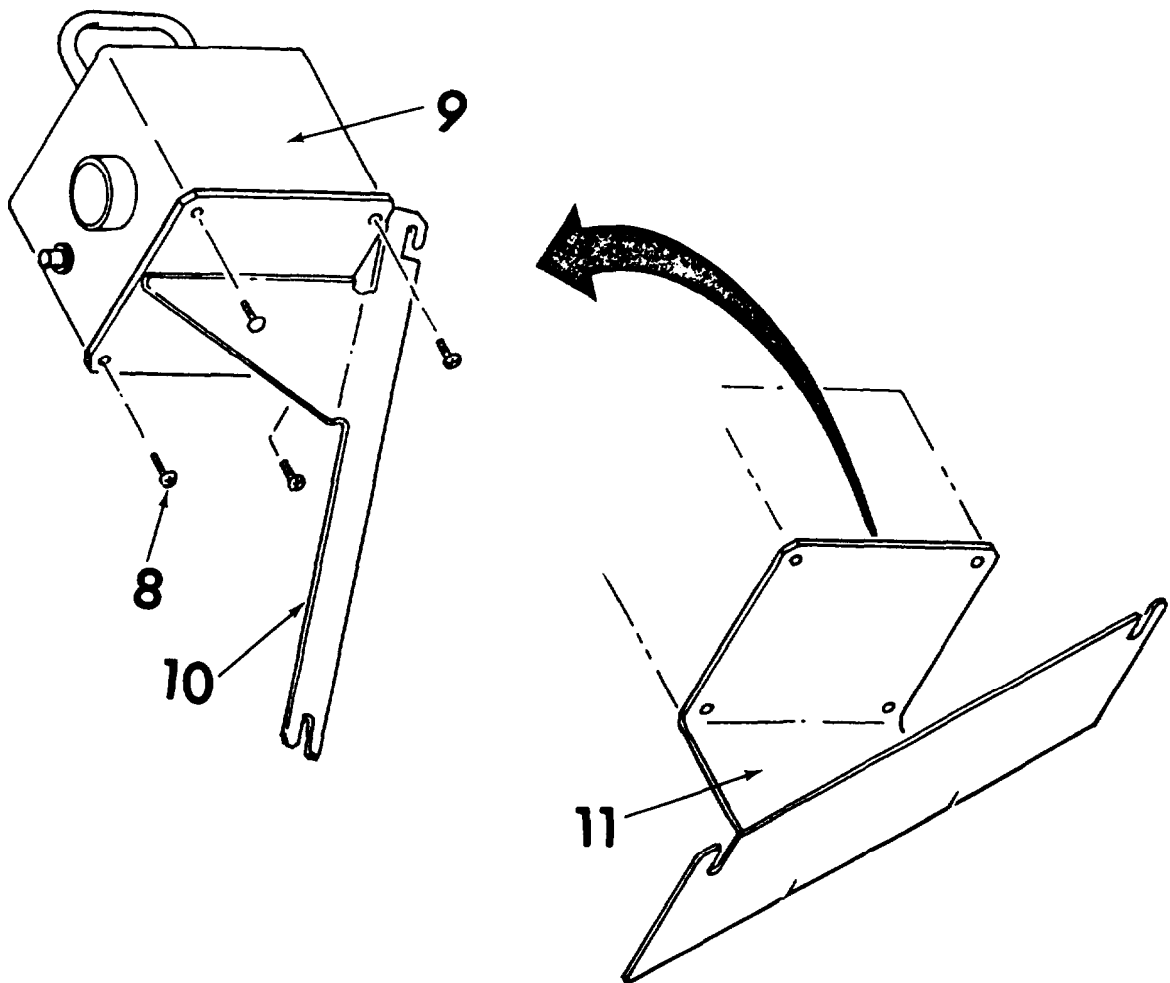

CABLING INSTALLATION TASKS - LIST

<u>Task</u>	<u>Title</u>	<u>Page</u>
1.	Obtain Equipment	2-46
2.	Inspect Headset-CKI Cable Assembly (W1)	2-47
3.	Install Headset-CKI Cable Assembly (W1)	2-48
4.	Inspect AKI/Smoke-ACIA Cable Assembly (W2)	2-51
5.	Install AKI/Smoke-ACIA Cable Assembly (W2)	2-52
6.	Inspect ACIA Interface Cable Assembly (W3)	2-54
7.	Install ACIA Interface Cable Assembly (W3)	2-55
8.	Install Remaining Cables	2-57

Cabling Installation Task 1: Obtain Equipment. Completion of Inside Installation Tasks requires equipment listed and illustrated below. Locate and set aside this equipment.

2 Headset-CKI (W1) Cable Assemblies

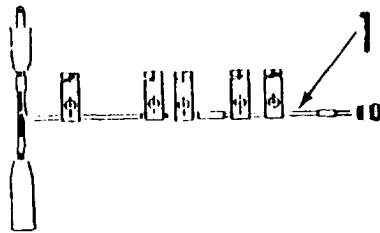

1 AKI/Smoke-ACIA (W2) Cable Assembly

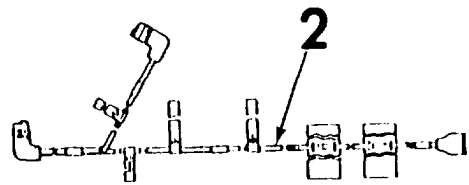

1 ACIA Interface (W3) Cable Assembly

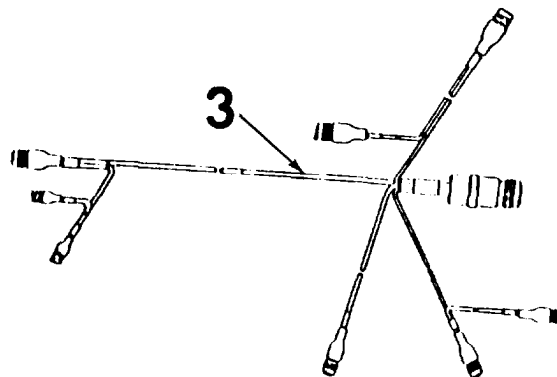

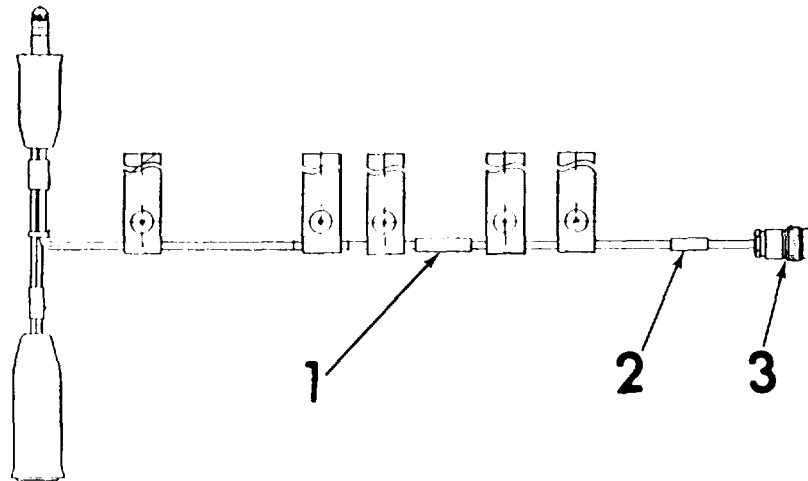
Cabling Installation Task 2: Inspect Headset-CKI Cable Assembly (W1).

Find cable assemblies labelled HEADSET-CKI (1). There are two assemblies. Each cable segment should have label (2) showing where it goes. Check all connectors (3) for obvious damage.

Report any damage on DA Form 2404. Replace Headset-CKI (W1) Cable Assembly only if not operable.

Cabling Installation Task 3: Install Headset CKI Cable Assembly (W1).

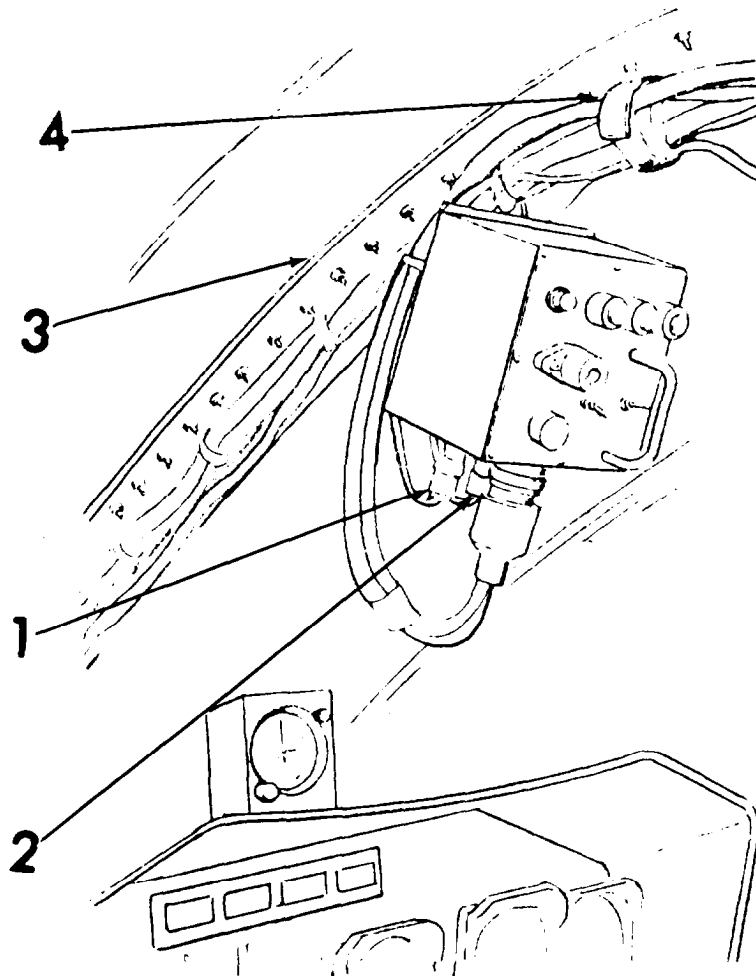

Locate W1 connector P1 (1) on Headset-CKI Cable Assembly. Connect P1 to left connector of CKI.

Locate W1 connector P1 (2) on remaining Headset-CKI Cable Assembly. Connect P1 to remaining connector on side of CKI.

Run W1 cables behind CKI and up center windshield retainer (3). Use attached fastener tape straps (4) to secure W1 cables to the wiring bundles.

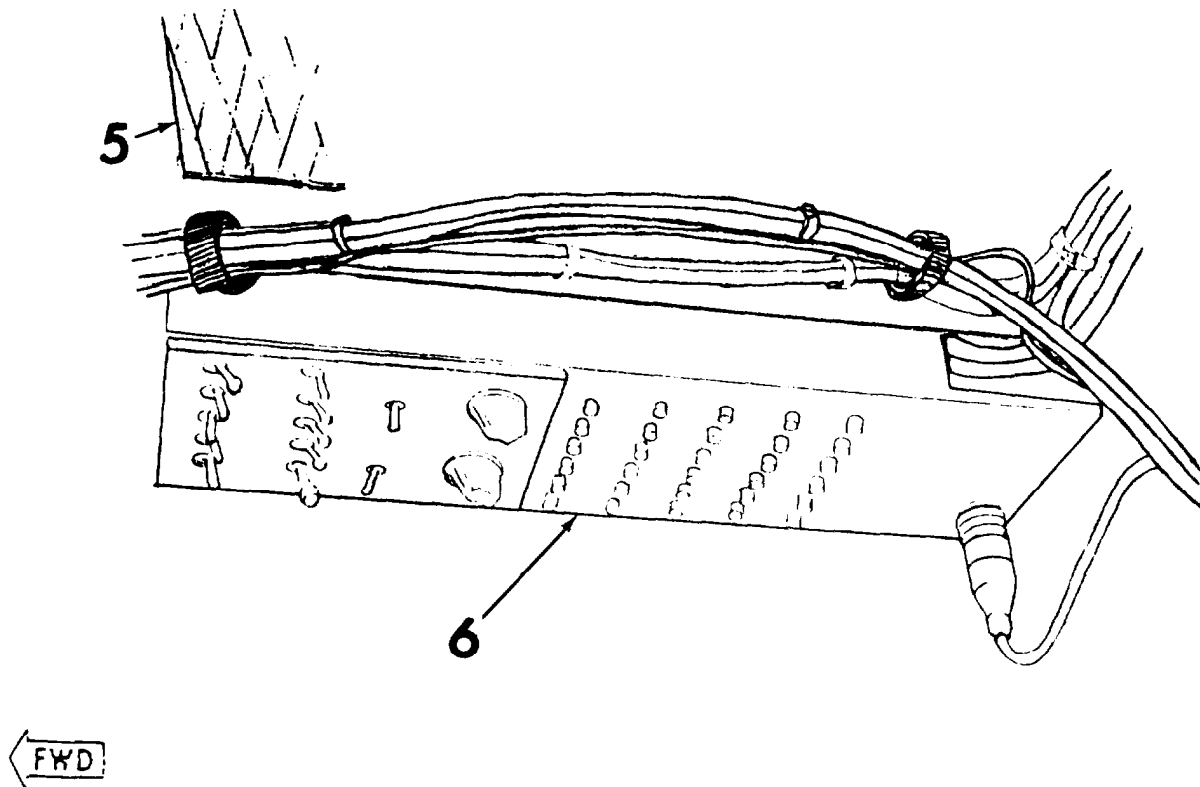

Unfasten and fold back soundproofing blanket (5) above pilot's and copilot's seat. Run W1 cables along left and right side of overhead console (6).

When you reach area immediately above copilot's seat back, run W1 cable along area above copilot's seat back to left door.

When you reach area immediately above pilot's seat back, route W1 cable to pilot's Intercom connector.

Cabling Installation Task 3: Install Headset-CKI Cable Assembly (W1) (Cont)

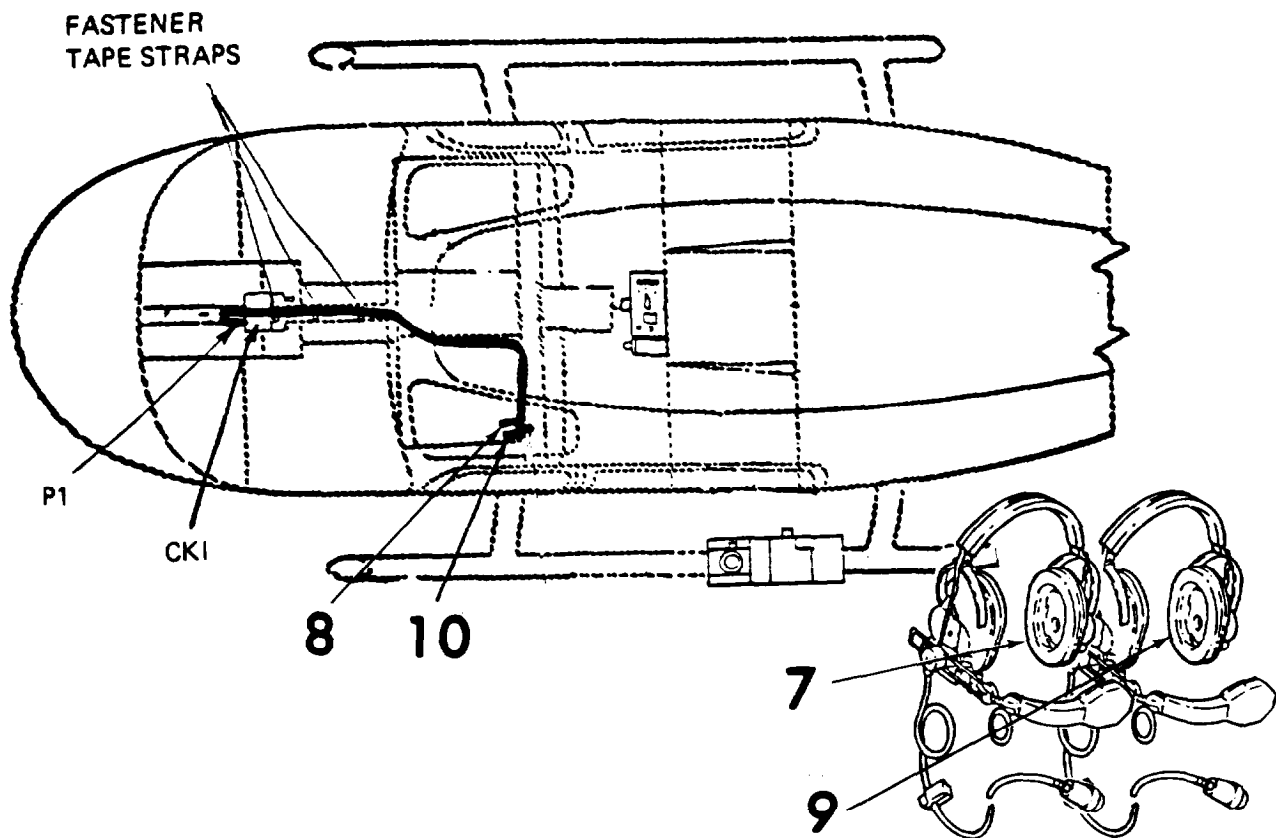

Plug both P2 connectors into aircraft intercom connector.

Copilot will plug his headset (7) into one P3 (8).

Pilot will plug his headset (9) into remaining P3 (10).

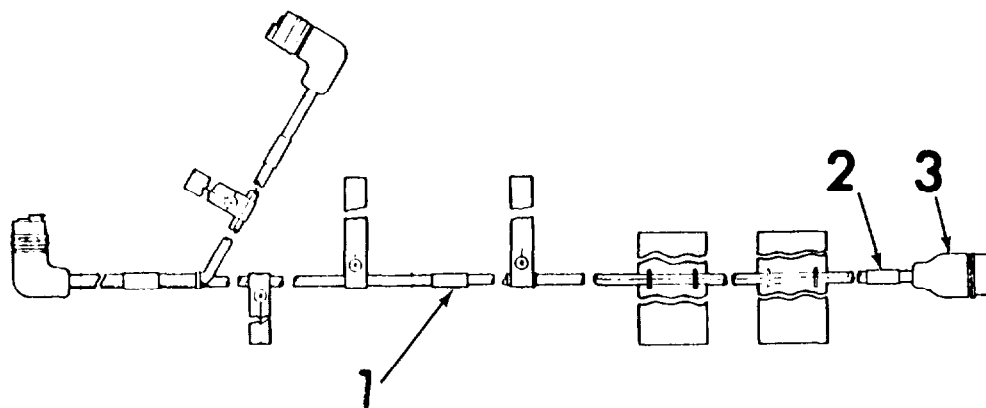
Cabling Installation Task 4: Inspect AKI/Smoke-ACIA Cable Assembly (W2).

Find cable assembly (1) labelled AKI/Smoke-ACIA (W2). Each cable segment should have label (2) showing where it goes. Check all connectors (3) for obvious damage.

Report any damage on DA Form 2402. Replace AKI/Smoke-ACIA Cable Assembly only if not operable.

Cabling Installation Task 5: Install AKI/Smoke-ACIA Cable Assembly (W2).

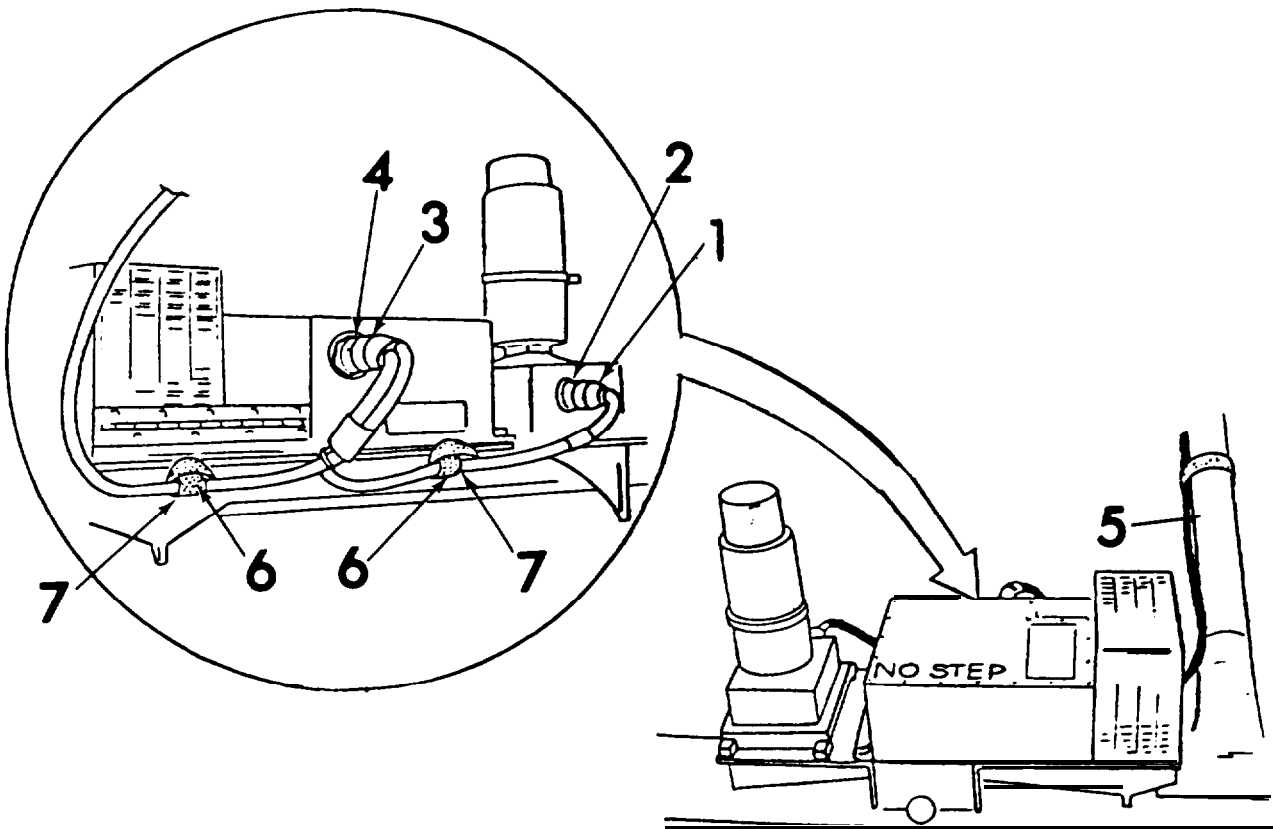

Mate connector P3 (1) with receptacle (2) on side of AKI.

Mate connector P1 (3) with receptacle (4) on side of smoke assembly.

Run W2 cable to aft crosstube (5). Secure W2 cable to AKI/Smoke mount using attached fastener tape straps (6) through two slots (7).

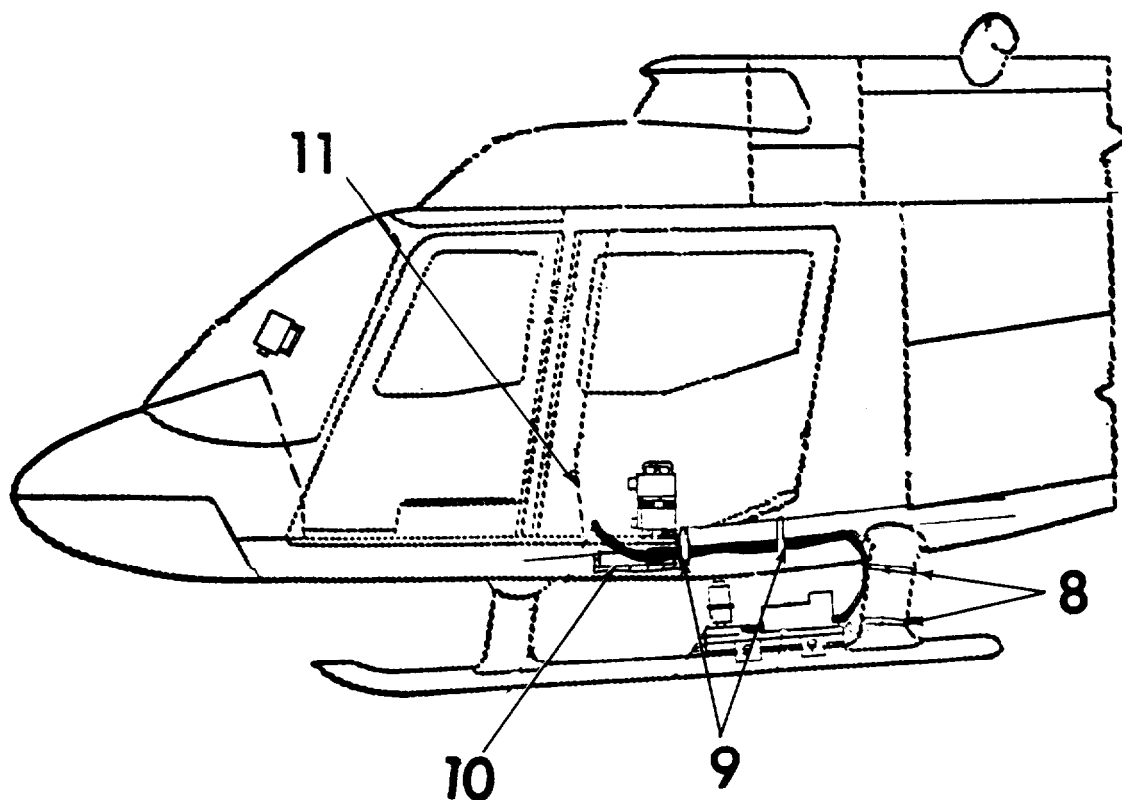

Proceed up aft cross tube to lower left fuselage. Use attached fastener tape straps (8) to secure W2 cable to aft crosstube.

Run W2 cable forward along bottom side of lower left belt. Use fastener tape straps (9) attached to belt to secure W2 cable to bottom of belt.

WARNING

Make sure cables are secured below
belt and NOT behind it.

Press cable pad (10) against fastener tape on fuselage below passenger door (11).

Open left passenger door (11). Lay rest of W2 cable and connector P2 on left side of passenger compartment floor. Press cable pad against fastener tape on inside of passenger compartment below door.

Cabling Installation Task 6: Inspect ACIA Interface Cable Assembly (W3).

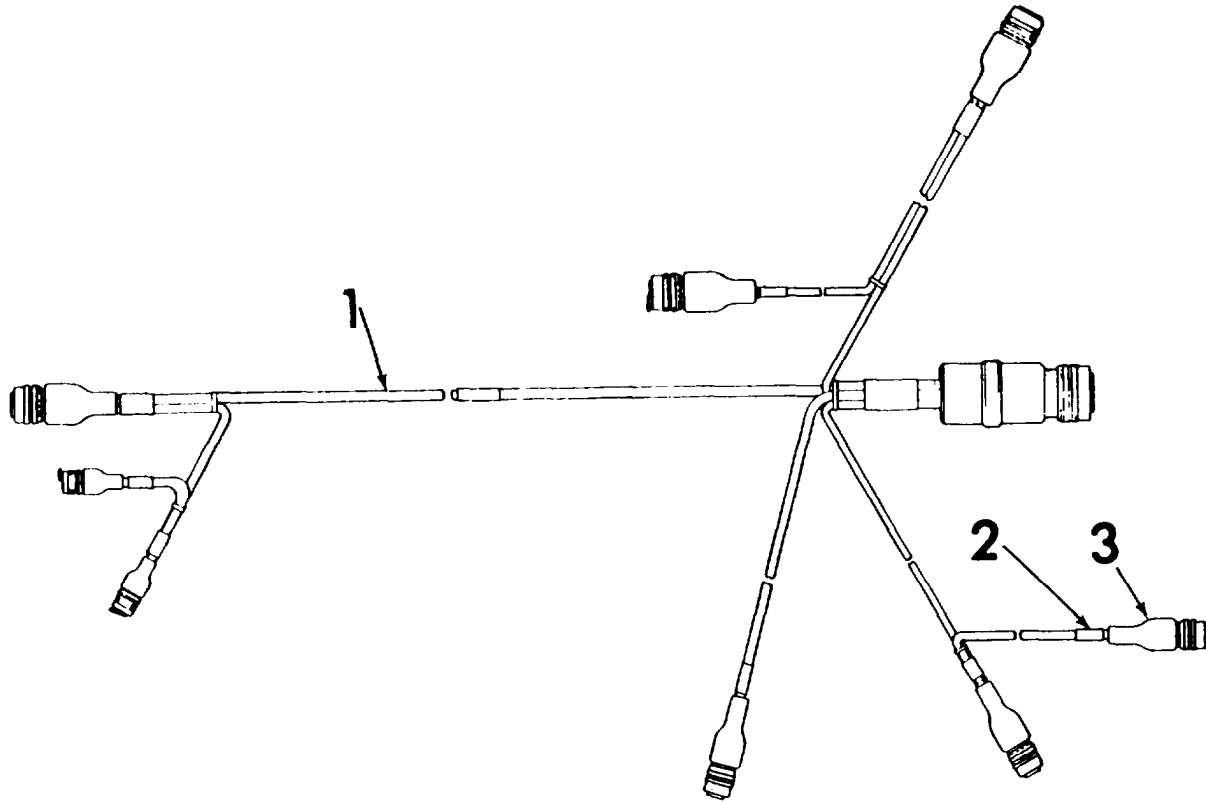

Find cable assembly (1) labeled ACIA INTFC (W3)

Each cable segment should have label (2) showing where it goes. Check all connectors (3) for obvious damage.

Report damage on DA Form 2404. Replace ACIA Interface Cable Assembly only if not operable.

Cabling Installation Task 7: Install ACIA Interface Cable Assembly (W3).

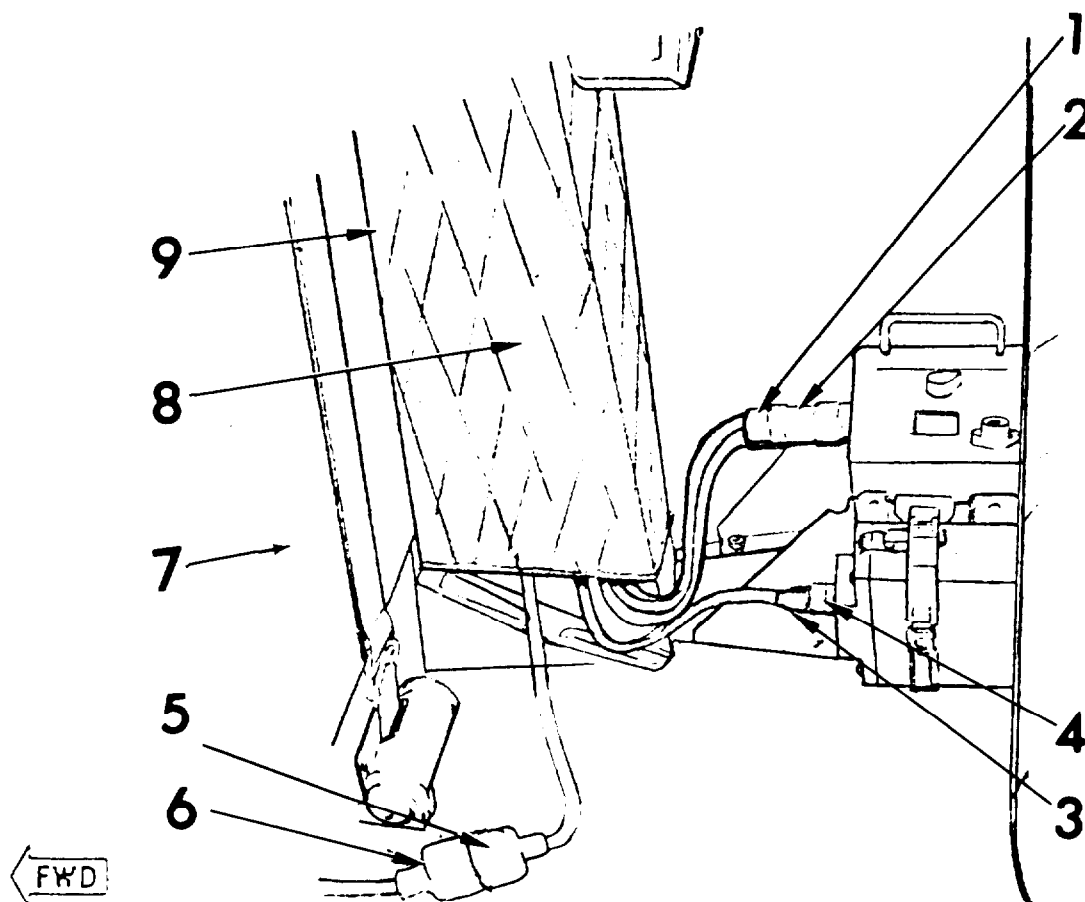

Connect W3 connector P1 (1) into receptacle (2) on side of ACIA.

Connect W3 connector P3 (3) into receptacle (4) on lid of battery box.

Mate connector P8 (5) of W3 cable with connector P2 (6) of W2 cable. Position mated cables on left side of passenger compartment floor, just aft of crew seat bulkhead (7).

Unfasten and fold back soundproofing blanket (8) on left side of center post (9).

Route W3 connectors P2 and P7 up center post between center post and soundproofing blanket.

Cabling Installation Task 7: Install ACIA Interface Cable Assembly (W3) (Cont).

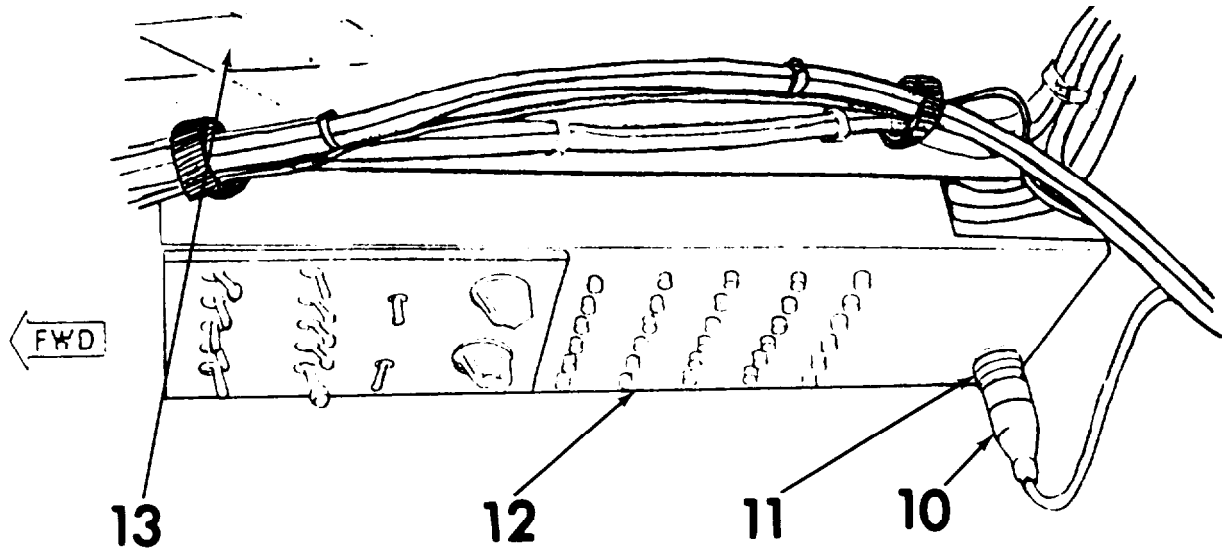

Attach connector P7 (10) to signal light receptacle (SIG LT RECP) (11) on overhead console (12). Route connector P2 along left side of overhead console.

Run W3 connector P2 along center windshield retainer (14) behind CKI. Attach W3 connector P2 (16) to receptacle (17) on CKI bottom. Secure W3 and W1 cables to wire bundles using fastener tape straps (15) attached to W1 cable.

Secure soundproofing blanket (13) above copilot's seat and on left side of center post.

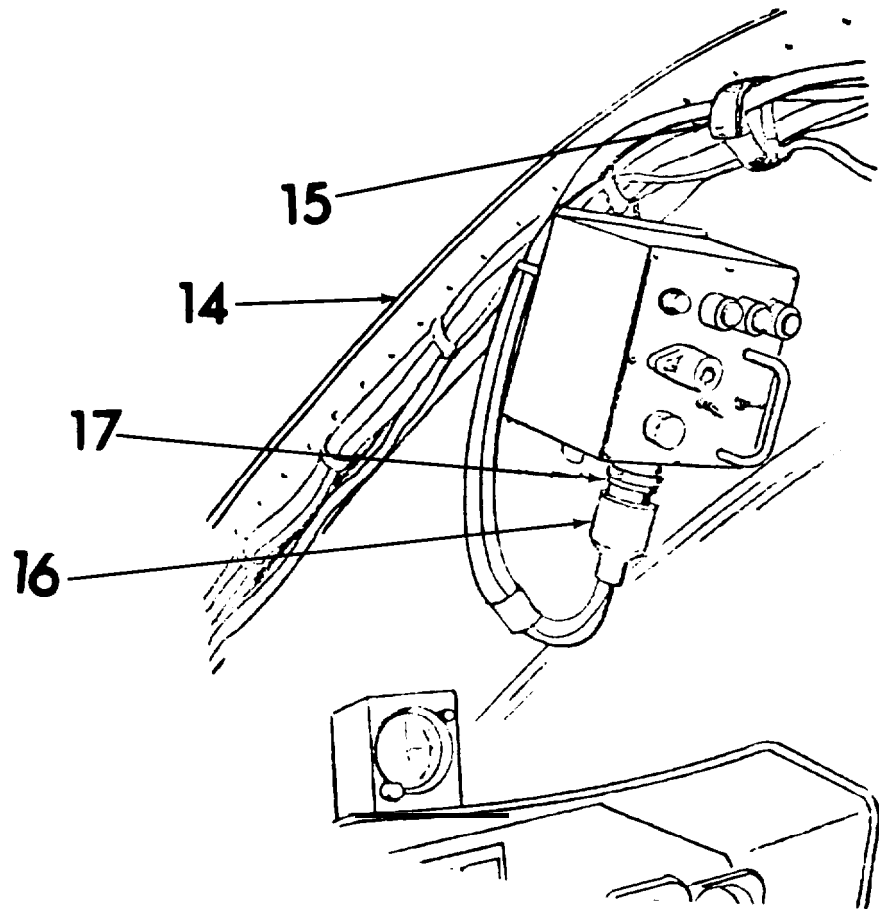

Cabling Installation Task 8: Install Remains Cables

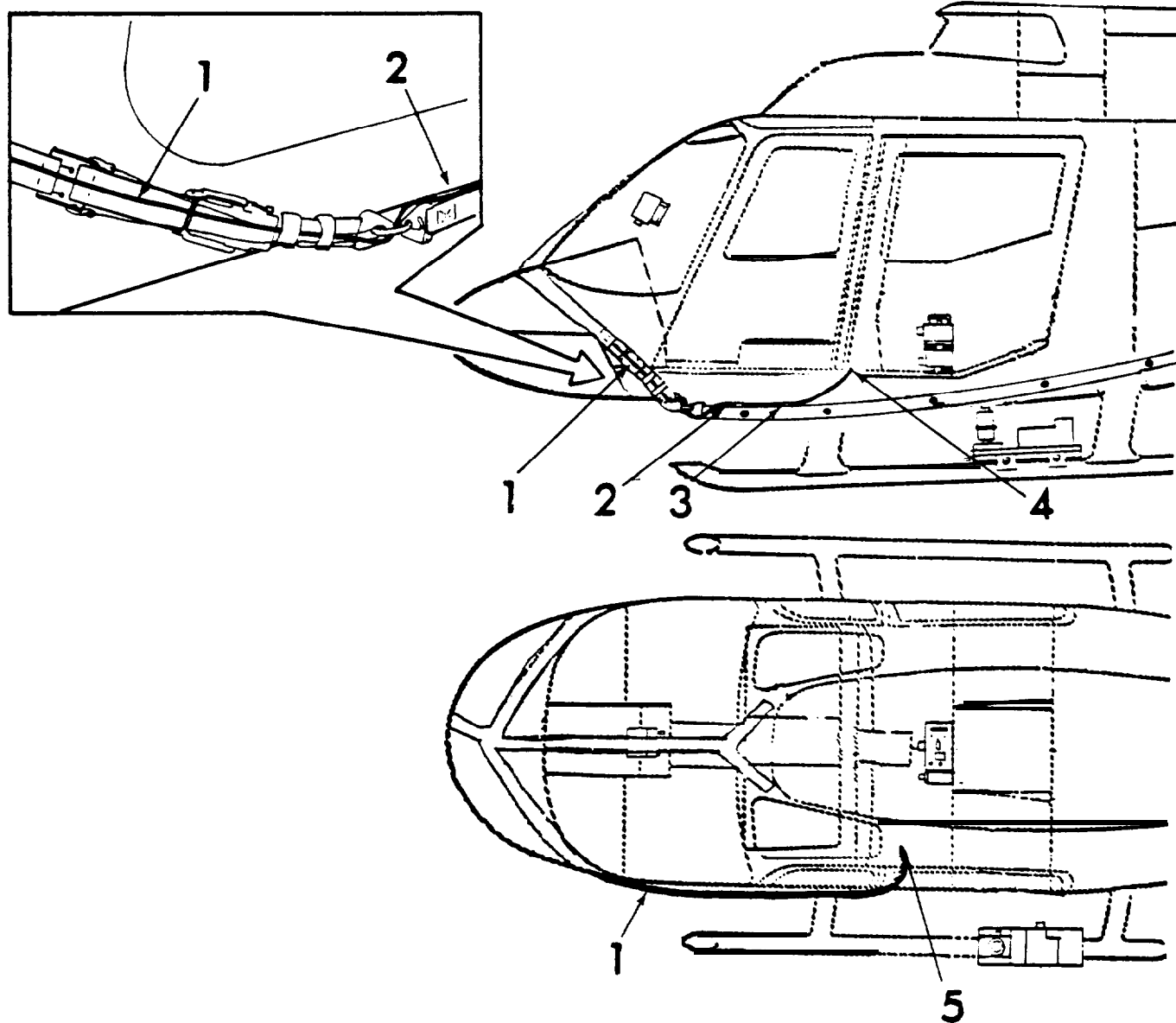

Run nose belt cable (1) aft through elastic loops on nose belt and through ring assembly along top of lower left belt (2). Secure cable to belt using fastener tape straps (3) attached to belt.

Run nose belt cable into interior of helicopter through left passenger door (4).

Connect nose belt cable connector (5) to connector P5 of W3 cable. Position mated connectors on left side of passenger compartment floor, just aft of copilot seat bulkhead.

Cabling Installation Task 8: Install Remaining Cables (Cont).

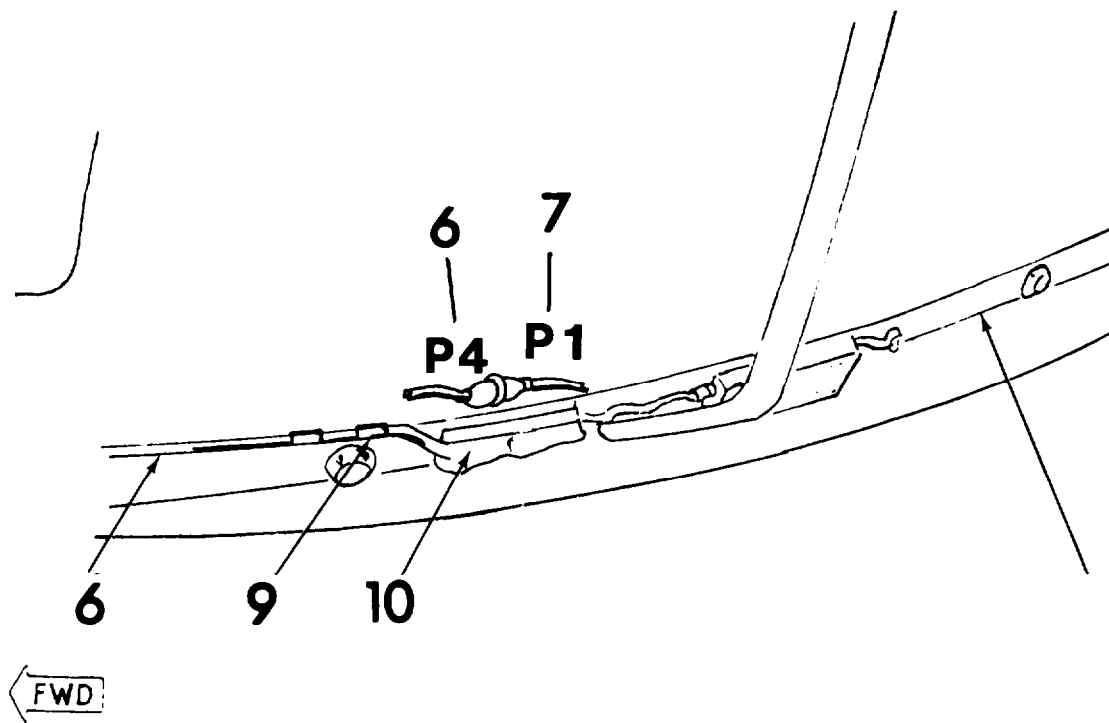

Route connector P4 (6) out left passenger door aft and connect to connector P1 (7). Secure cable to top of lower left belt (8) using fastener tape straps (9) attached to belt.

Fold flap (10) over mated connectors and secure flap with attached fastener tape.

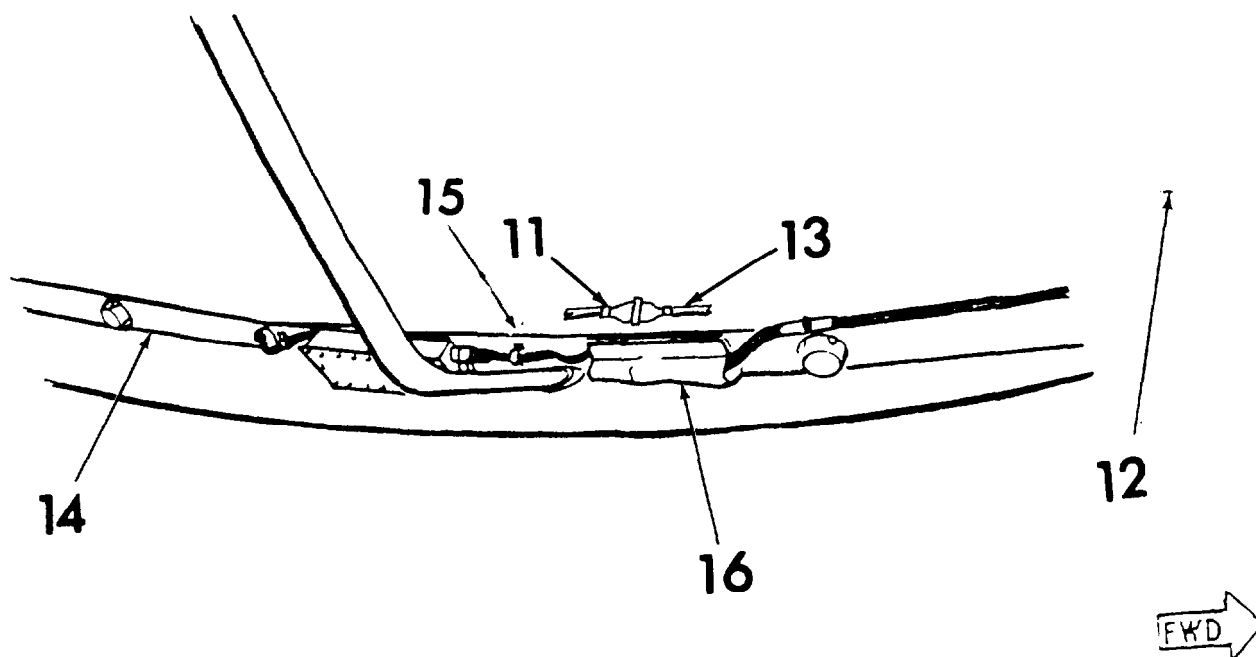

Run connector P6 (11) out right passenger door (12) aft and connect to connector P1 (13). Secure cable to top of lower right belt (14) using fastener tape straps (15) attached to belt.

Fold flap (16) over mated connectors and secure flap with attached fastener tape.

Cabling Installation Task 8: Install Remaining Cables (Cont).

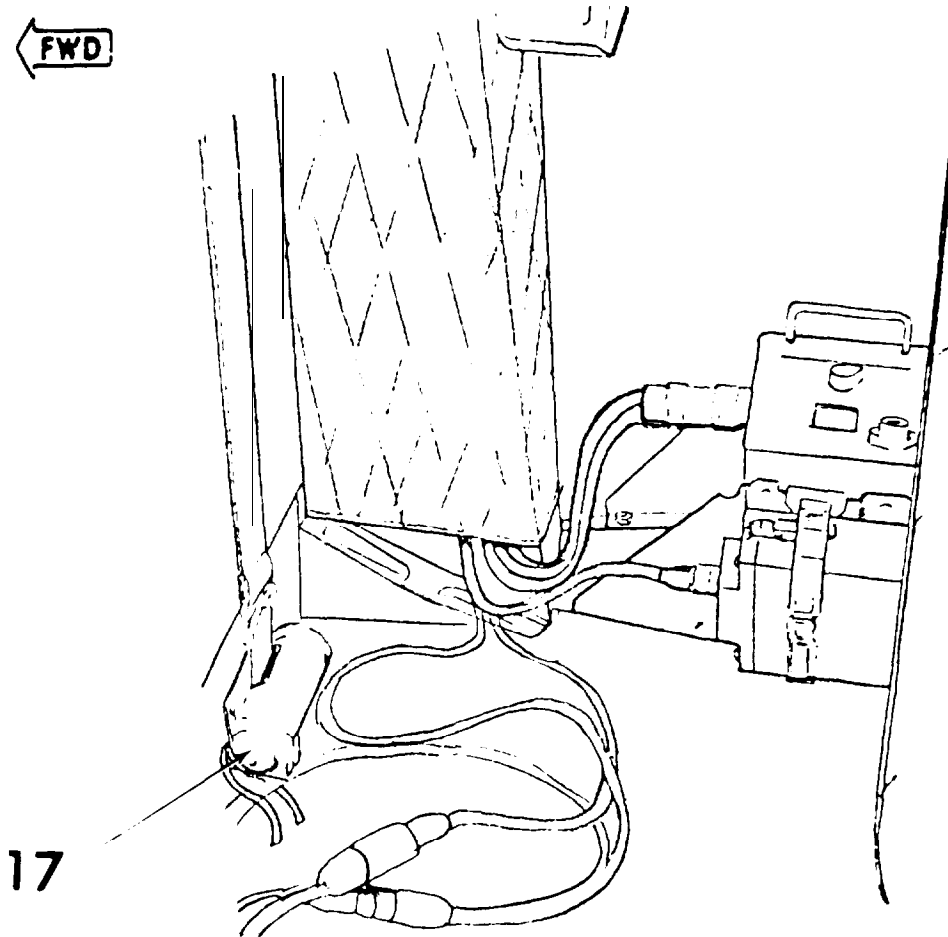

Secure cables on left side of passenger compartment floor to copilot inertia reel (17) using fastener tape strap.

Secure cables coming through left side of passenger door under P4 fastener pad. Attach to fastener tape inside, under passenger door.

INITIAL ADJUSTMENTS, DAILY CHECKS AND SELF TEST

<u>Task</u>	<u>Page</u>
Alignment Task	2-61
Test Tasks	2-62

Alignment Task. Some of the detectors on each belt are movable. They must be aligned by turning the movable detectors to the proper color index marks (1). The index marks are located on the ferrule (2) at the base of each detector (3).

There are three different color dots - red, green, and white. The detectors on each belt are turned to one of these colors as given in Table 2-4.

Pull up spring loaded plunger (4) and hold in up position.

Turn detector until index line (5) on side of detector base points to proper color index mark (1) as listed in Table 2-4.

Release plunger. Make sure plunger fully seats in its down position.

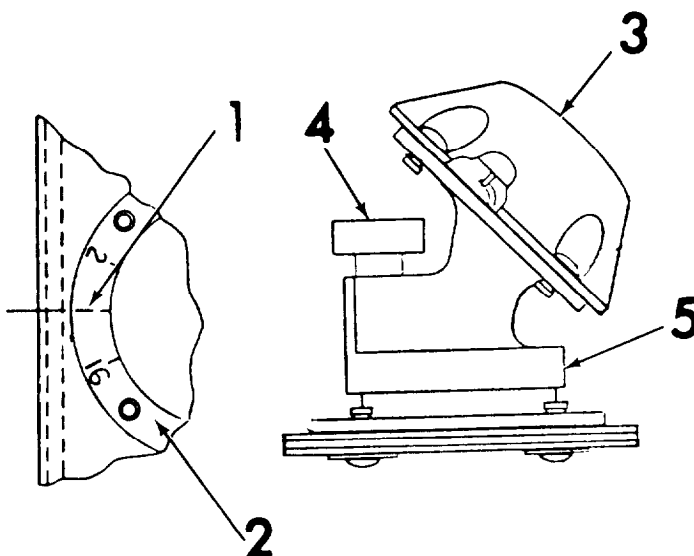

Table 2-4. Detector Belt Color Codes

Detector Belt	Color
Top Left	Red or White
Bottom Left	Red or White
Top Right	Green or White
Bottom Right	Green or White
Nose	White

Test Tasks

WARNING

Make sure a grenade is NOT installed in Smoke Indicator.

Open up Smoke Indicator housing cover (1) and pull extractor shaft (2) out to its extended position.

Make sure two 6 V batteries have been installed in battery box (3) and that aircraft 24 V dc (auxiliary power circuit) is on.

Ensure that system switch (4) on CKI is ON.

Turn switch (6) to HIT/KILL WPN IDENT. Push PRESS TO READ button (5) on ACIA. Verify display (7) indicates 00.

If any indication is not correct. turn to Troubleshooting, Page 3-1.

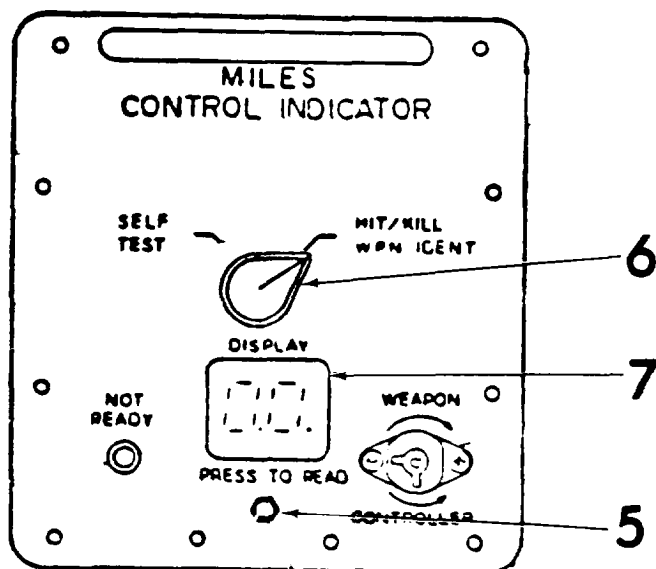
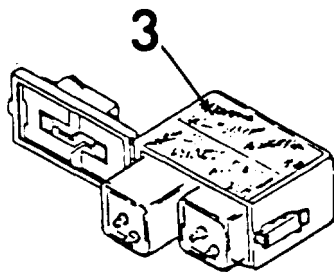
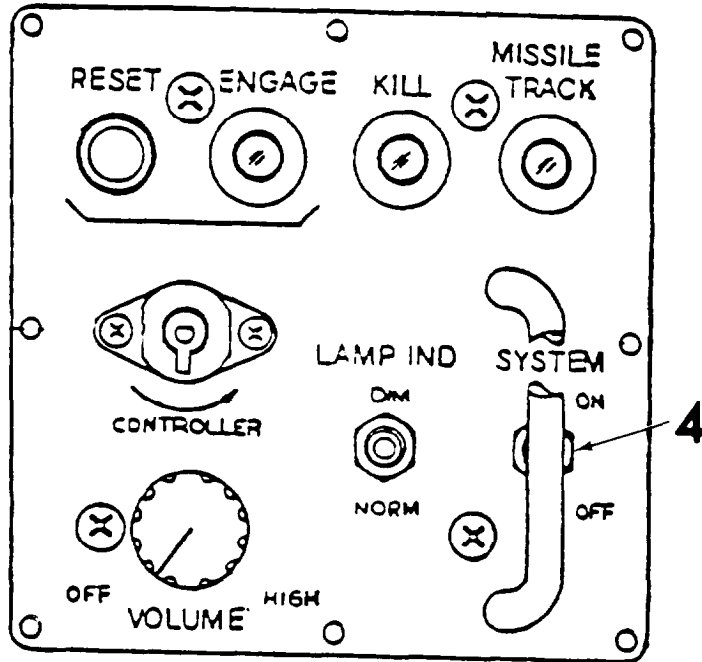
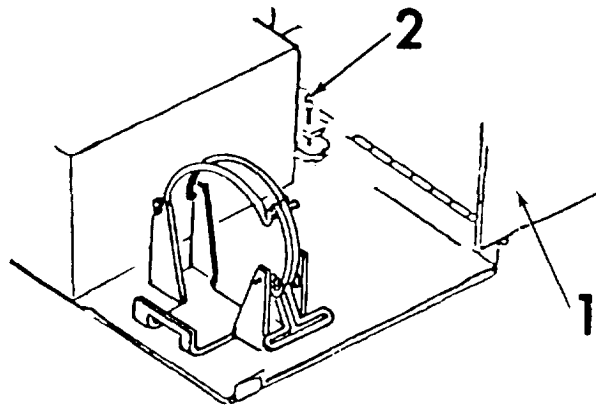

Ask Controller to insert his green Controller Key in receptacle (8) on the ACIA. turn to CONTROLLER position momentarily. then remove key.

Turn switch (6) to SELF TEST. Verify display (7) indicates 88.

Verify NOT READY light (9) is OFF

If any indication is not correct. turn to Troubleshooting. page 3•1

Have Controller Insert an orange weapon key in receptacle (6) on ACIA and turn to the WEAPON position.

Turn switch (6) to HIT/KILL WPN IDENT. Push PRESS TO READ button (5) on ACIA Verify display (7) indicates 99.

Verify NOT READY light (9) is on.

Verify AKI (10) flashes continuously.

Verify CKI ENGAGE light (11) is OFF.

Verify CKI KILL light (12) is ON

Verify intercom tone is OFF.

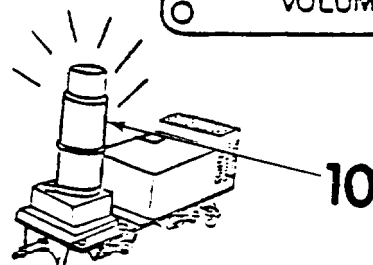
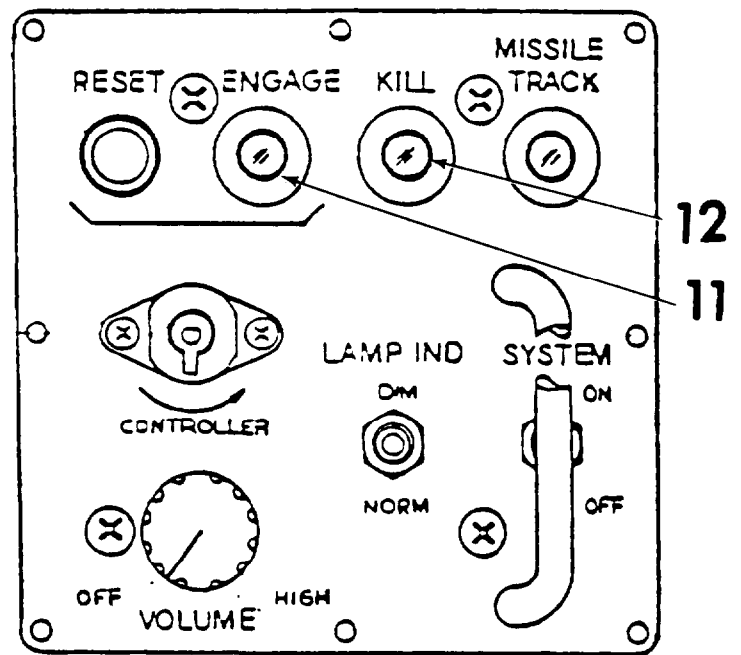
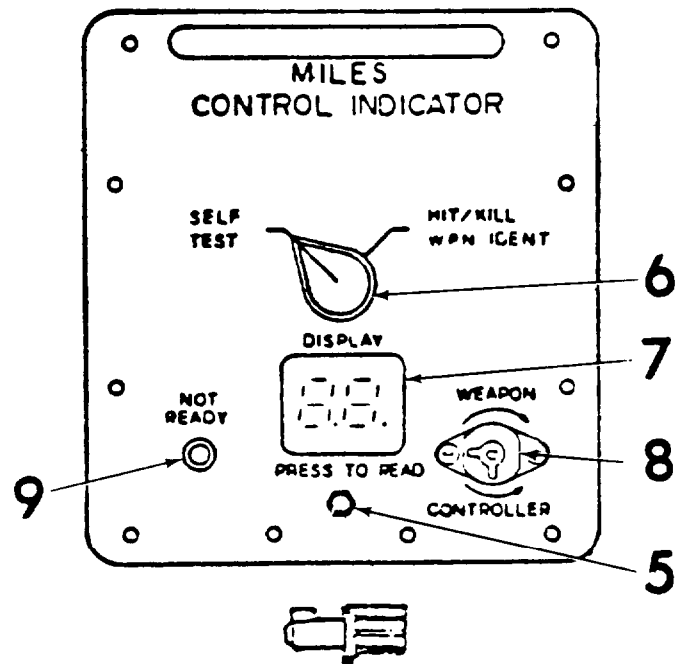

Test Tasks (Cont)

NOTE

The TRACK light is not used on the OH-58 MILES system and will always be OFF.

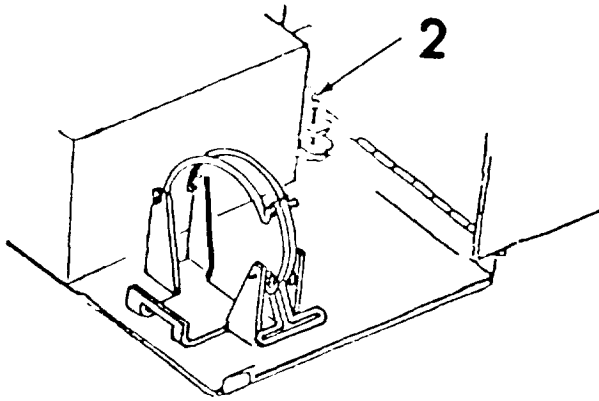

On Smoke Indicator verify that extractor shaft (2) moves into smoke indicator housing.

Remove weapon key.

Verify intercom tone is ON. Turn VOLUME knob (13) to check.

If any indication is not correct, go to Troubleshooting, page 3-1.

Have Controller insert Controller Key in CKI receptacle (14) and turn to CONTROLLER position, then remove key. If ENGAGE light on CKI is ON, push RESET button. Verify AKI (10) IS off.

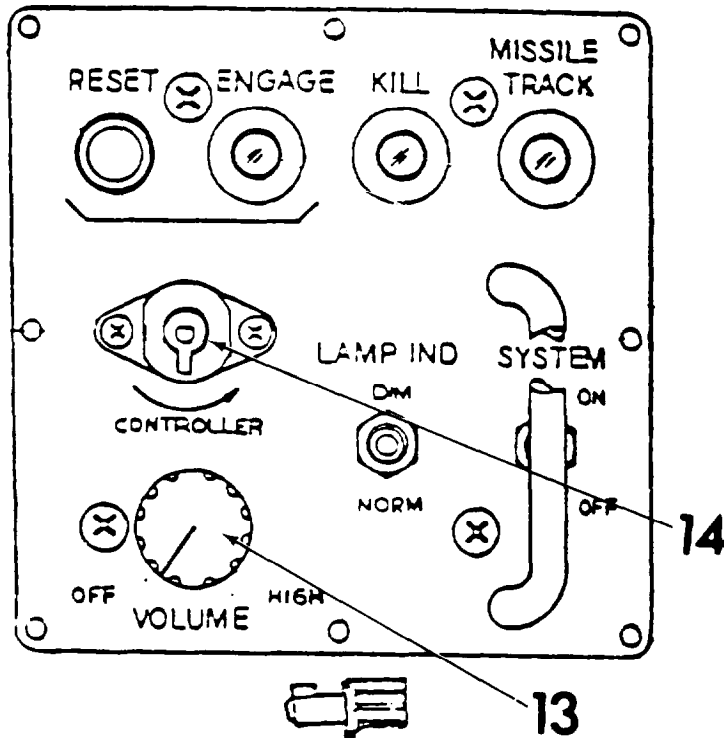

Turn ACIA switch (6) to SELF TEST. Push PRESS TO READ button (5). Verify display (7) indicates 88.

Verify NOT READY light (9) IS OFF.

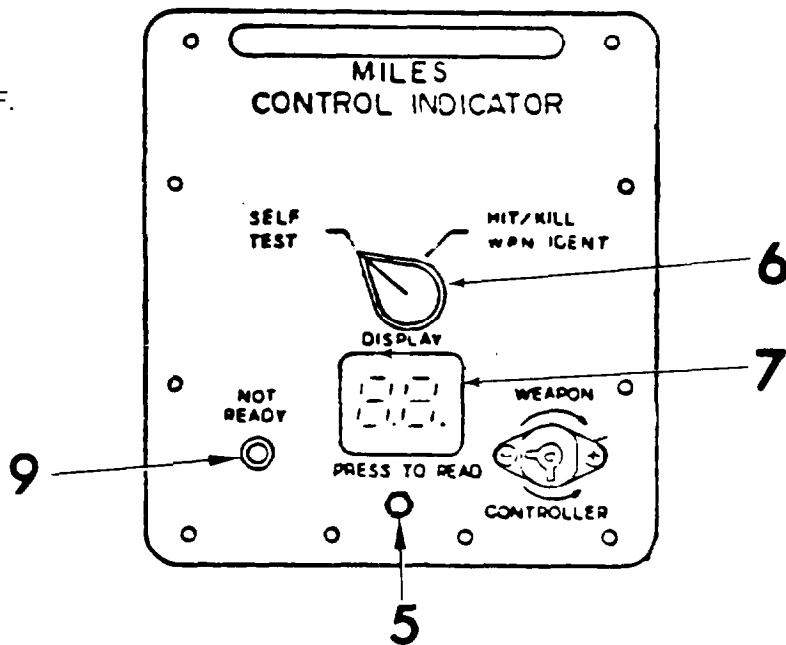
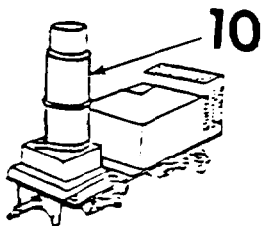

Verify CKI KILL light (12) is OFF.

Verify CKI ENGAGE light (11) is OFF.

Verify intercom tone is OFF. Check VOLUME knob (13)

If any indication is not correct, turn to Troubleshooting, page 3-1.

Reset Smoke Indicator by pulling extractor shaft (2) out to its extended position.

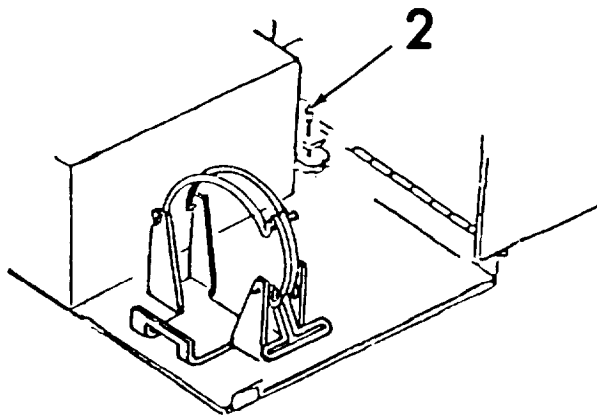
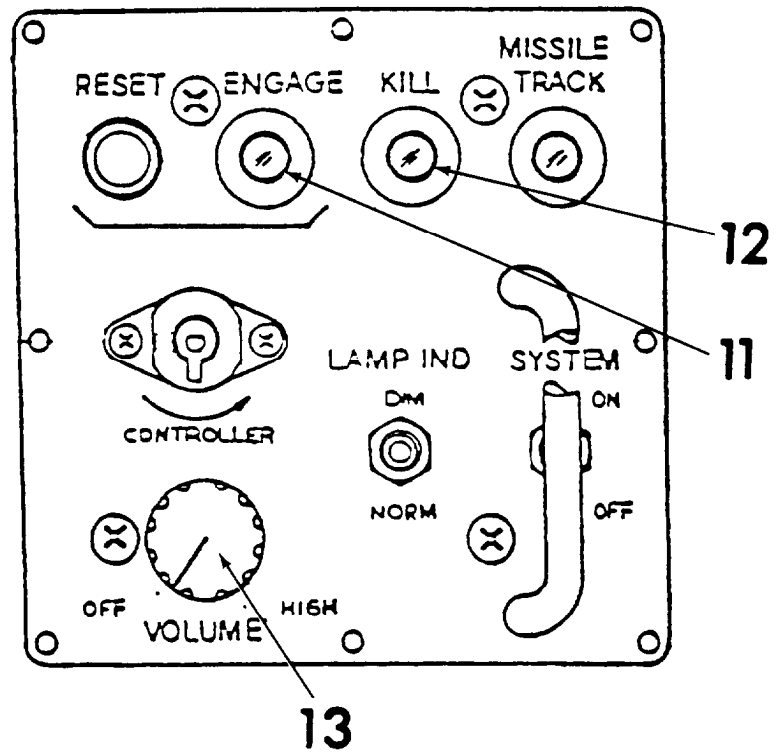

Test Tasks (Cont)

Have Controller fire once at each detector with Controller Gun (15) set in NEAR MISS mode. Fire from a distance of at least 5 feet. Verify AKI (10) flashes twice and extractor shaft (2) in Smoke indicator does not move.

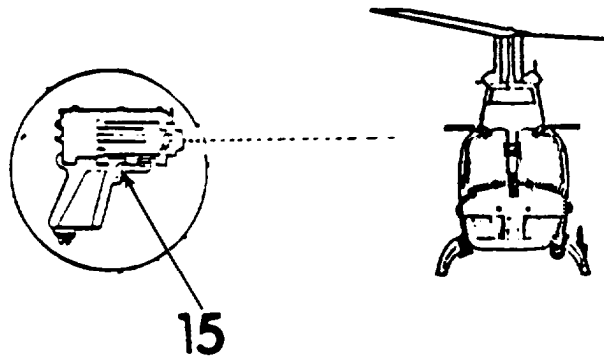

Verify CKI KILL light (12) is OFF

Verify CKI ENGAGE light (11) is ON.

Verify intercom tone beeps twice.

NOTE

It is OK for one detector to be bad on each belt.

If any indication is not correct, turn to Troubleshooting page 3-1.

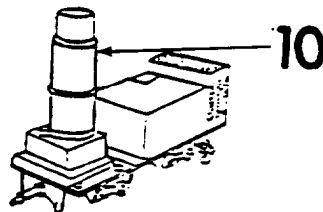
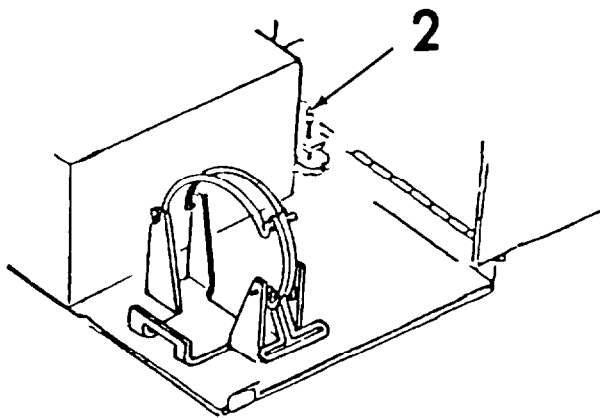
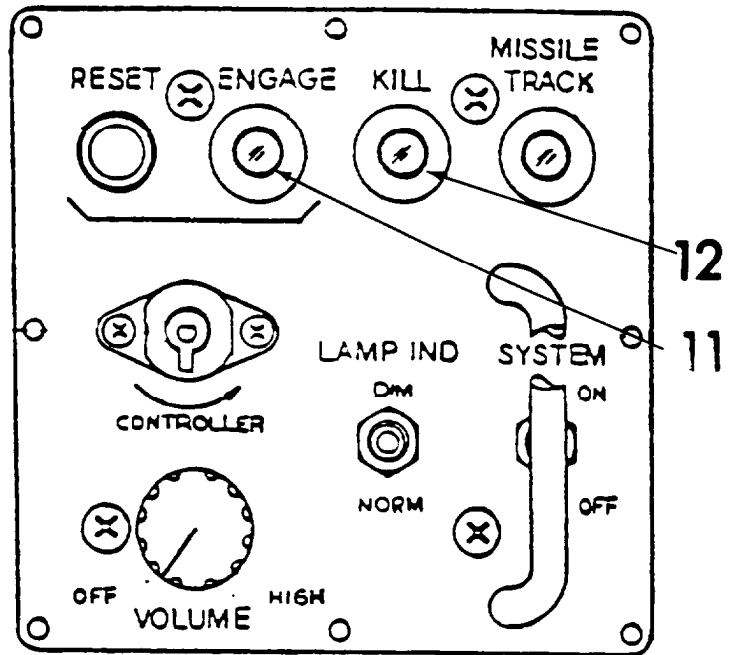

Depress RESET switch (16) on CKI and verify that ENGAGE light (11) is OFF.

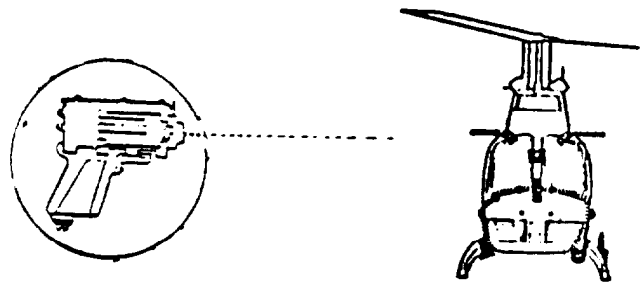

Have Controller fire at a detector with one burst of UNIVERSAL KILL words and verify AKI (10) flashes continuously and extractor shaft (2) on the Smoke Indicator moves in. Verify CKI KILL light (12) is ON.

Verify CKI ENGAGE light (11) is OFF.

Verify intercom tone is ON.

Turn switch (6) to HIT/KILL WPN IDENT. Push PRESS TO READ button (5) on ACIA. Verify display (7) indicates 00.

Turn ACIA switch (6) to SELF TEST. Verify display (7) indicates 00.

Verify ACIA NOT READY light (9) is ON.

If any indication is not correct, turn to Troubleshooting page 3-1.

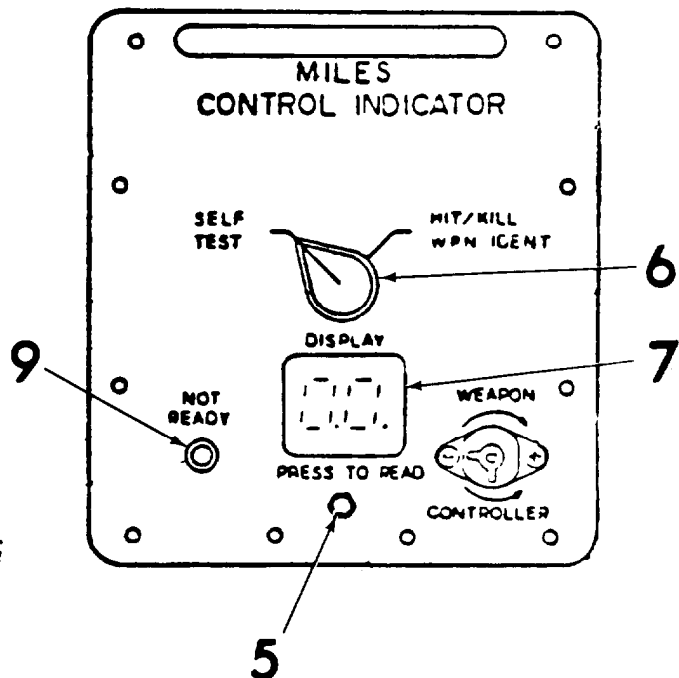
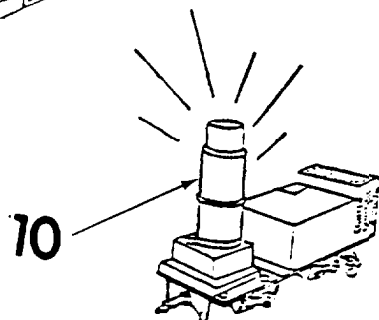
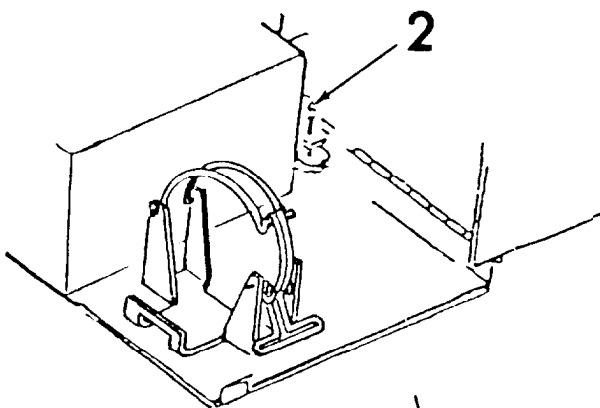
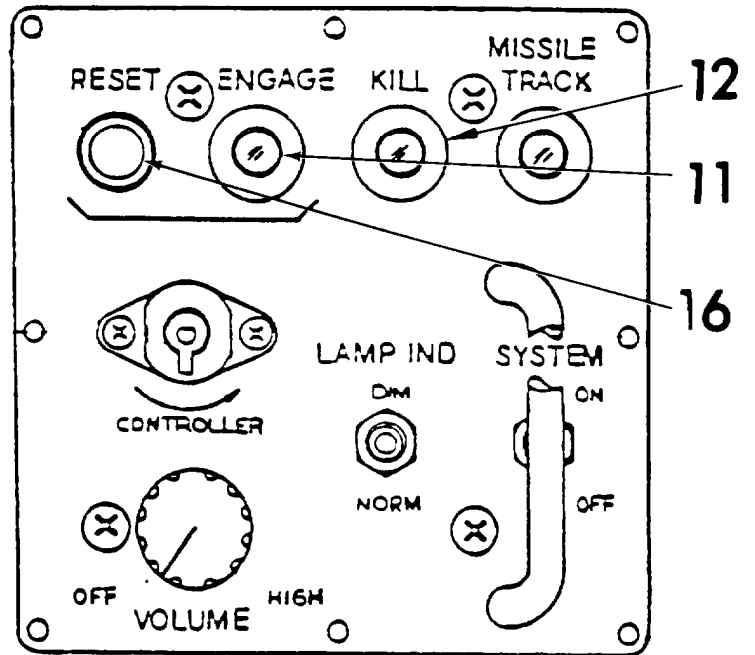

OPERATING PROCEDURE

OPERATIONAL TASKS - LIST

<u>Task</u>	<u>Title</u>	<u>Page</u>
1.	Complete Operator and Crew Member Checklist	2-69
2.	Initialize MILES System	2-72
3.	Install Smoke Grenade	2-73
4.	Night Operations	2-74
5.	Emergency Operations	2-74
6.	Recognizing Enemy Fire	2-75
7.	Resetting After a "KILL"	2-77

Operational Task 1: Complete Operator and Crew Member Checklist.

Perform the following Operator and Crew Member Checklist:

BEFORE INTERIOR AND EXTERIOR CHECK

WARNING

Do not preflight until all safety switches are set to their SAFE positions.

EXTERIOR CHECKFUSELAGE, FRONT

- | | | |
|----|--|-------|
| 1. | Nose belt snugly mounted against fuselage. | CHECK |
| 2. | Detector modules aligned with white dot. | CHECK |
| 3. | Belt end assemblies fastened to right and left side ring assemblies and nose belt with securely fastened lanyards. | CHECK |

FUSELAGE, LEFT SIDE

- | | | |
|----|---|-------|
| 1. | Lower belt snugly mounted against fuselage. | CHECK |
| 2. | Lower belt fastened to ring assembly and secured with lanyard. | CHECK |
| 3. | Lower belt fastened to rear harness assembly and secured with lanyard. | CHECK |
| 4. | Upper belt fastened to nose belt and secured with lanyard. | CHECK |
| 5. | Upper belt fastened to rear harness assembly and secured with lanyard. | CHECK |
| 6. | AKI/Smoke device secured to SKID. | CHECK |
| 7. | Cable connectors P1 and P3 mated with AKI/Smoke receptacles. | CHECK |
| 8. | W2 cable secured to AKI/Smoke mount. aft cross tube and lower fuselage using fastener strap ties and mounting pads and ties as detector belt. | CHECK |

Operational Task 2: Complete Operator and Crew Member Checklist (Cont).

FUSELAGE, LEFT SIDE

- | | | |
|-----|---|-------|
| 9. | Nose belt cable secured to detector belt using fastener ties. | CHECK |
| 10. | W3 cable connected to rear belt and fastened with belt ties. | CHECK |
| 11. | Belt cable connectors covered with flaps. | CHECK |

FUSELAGE, RIGHT SIDE

- | | | |
|----|--|-------|
| 1. | Lower belt snugly mounted against fuselage. | CHECK |
| 2. | Lower belt fastened to ring assembly and secured with lanyard. | CHECK |
| 3. | Lower belt fastened to rear harness assembly and secured with lanyard. | CHECK |
| 4. | Upper belt fastened to nose belt and secured with lanyard. | CHECK |
| 5. | Upper belt fastened to rear harness assembly and secured with lanyard. | CHECK |
| 6. | Belt cable connectors covered with flaps. | CHECK |

INTERIOR CHECK

PILOT/COPILOT AREA

- | | | |
|----|---|-------|
| 1. | CKI secured fastened to windshield retainer. | CHECK |
| 2. | CKI electrical connectors securely mounted and cables fastened with cable straps. | CHECK |
| 3. | Intercom functioning in headsets. | CHECK |

Passenger Area

- | | | |
|----|--|-------|
| 1. | ACIA/Battery box securely mounted | CHECK |
| 2. | Electrical connections scurely made | CHECK |
| 3. | Cable secured to inertia reels with fastener tape. | CHECK |

BEFORE TAKEOFF

1. Load smoke device with M18 smoke grenade only.

LOADED

BEFORE LEAVING HELICOPTER

1. ACIA DISPLAY switch.

HIT/KILL WPN
IDENT

2. PRESS TO READ

Momentarily press.
Read and note
number.

Operational Task 2: Initialize MILES System.

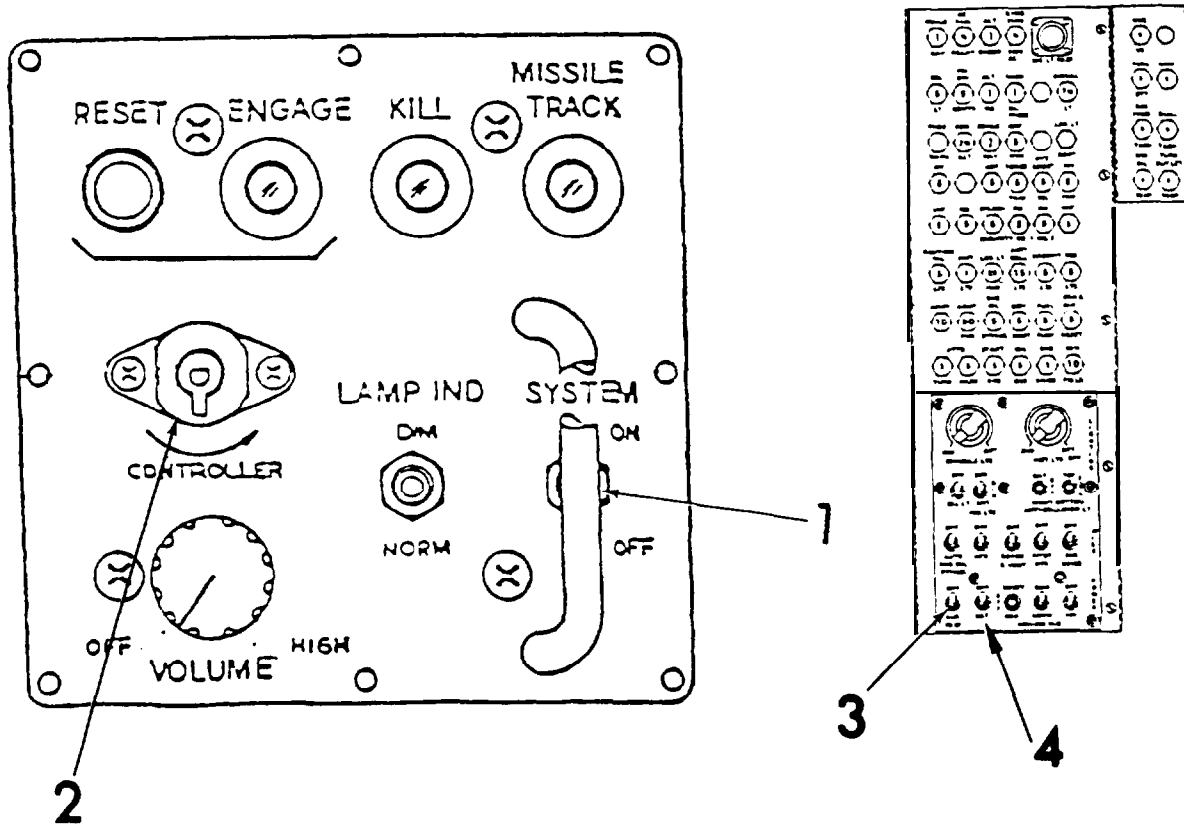

The SYSTEM ON/OFF switch is for emergency use only. It shuts down the MILES system and isolates it from other aircraft systems. If switch is turned OFF during an exercise. MILES will no longer operate until reset by a controller.

Turn CKI system power ON/OFF switch (1) to ON.

Initialize MILES OH-58 systems by having Controller insert controller key (green) in either CKI or ACIA receptacles (2). Cycle key to and from CONTROLLER position. Remove key.

Make sure aircraft power is ON. Use either Auxiliary Power Circuit breaker (3) or Battery Power switch (4).

Operational Task 3: Install Smoke Grenade

WARNING

M18 Smoke Canisters are the ONLY canisters authorized for use with the AKI Smoke Assembly. Care should be taken when handling expended canisters as they are initially hot to the touch. Failure to comply may result in Injury to Personnel.

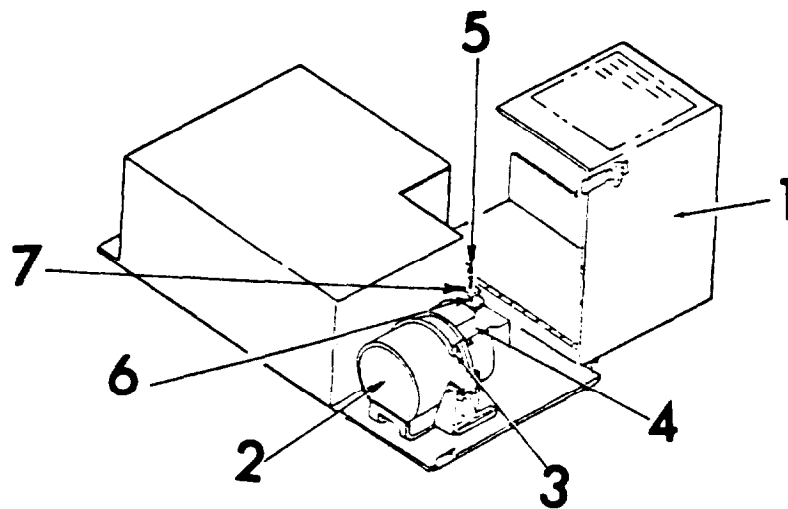

JUST PRIOR TO TAKEOFF on a MILES training mission, install an M18 smoke grenade in the smoke indicator mounted on left skid tube.

Unlatch and swing open canister cover (1).

Install M18 smoke grenade (2) (Item 8, Section II, Appendix D) in canister clamp (3) with spoon up. Secure grenade by securing clamp. Ensure that clamp does not restrict movement of grenade spoon (5).

Pull extractor shaft out to its extended position.

Connect clip (6) of extractor shaft to ring (7) of M18 smoke grenade. Insert locking pin.

Close and latch canister cover (1).

If operating without a smoke grenade, make sure extractor shaft is pushed into the smoke indicator housing.

Operational Task 4: Night Operations.

Irises are built into CKI light displays. When night vision goggles are worn these irises should be dimmed.

Turn LAMP IND switch (1) to DIM.

Turn each iris clockwise (2) to dim light.

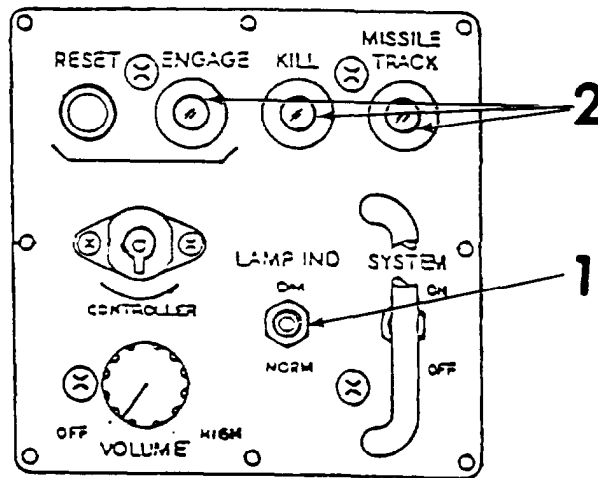

Operational Task 5: Emergency Operations.

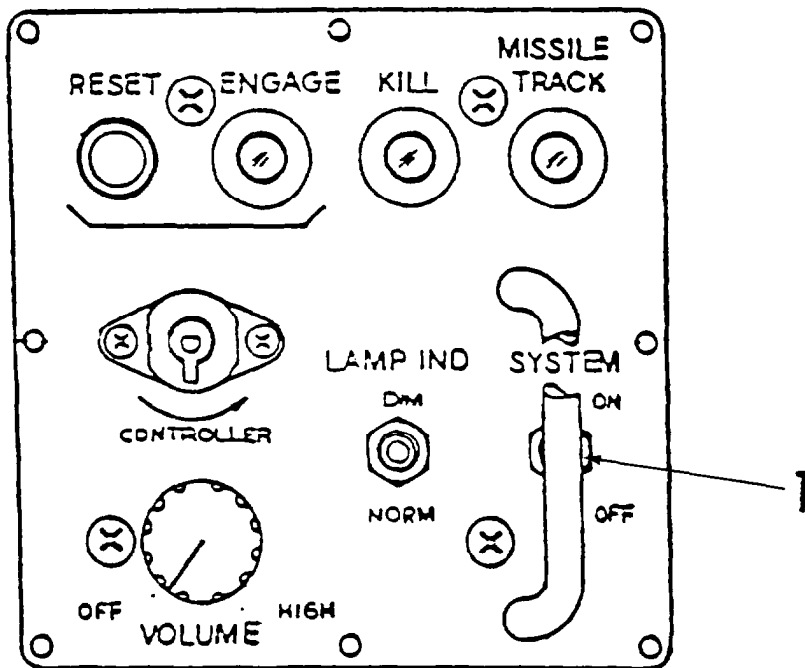

In an emergency the MILES system is shut off by turning CKI system switch (1) to OFF.

Operational Task 6: Recognizing Enemy Fire.

1. If you are hit by laser fire, the AKI (1) will flash. You will also hear tones on the intercom unit. A brief alarm (two AKI flashes and two intercom beeps) means a "NEAR MISS." Repeated alarm (four to six intercom tones and four to six AKI flashes) means a "HIT." Continuous AKI flashing and intercom tone indicates a "KILL."

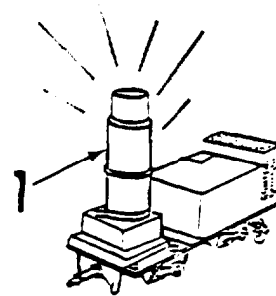

2. To determine what kind of weapon has fired on you, turn the switch (2) on the ACIA to HIT/KILL position. Press PRESS TO READ button (3). Display (4) will show a number. Use the chart below to match number on display with type of weapon firing on you.

<u>Display Number</u>	<u>Weapon</u>
00	Controller Gun
07	TOW
08	Dragon
12	105 mm
13	152 mm
14	2.75 inch Rocket
15	Viper
16	120 mm
22	25 mm
23	20 mm Cannon
24	M2/M85
25	Chaparral
26	Stinger
27	M16 or M60 Machine Gun
99	Self-Kill

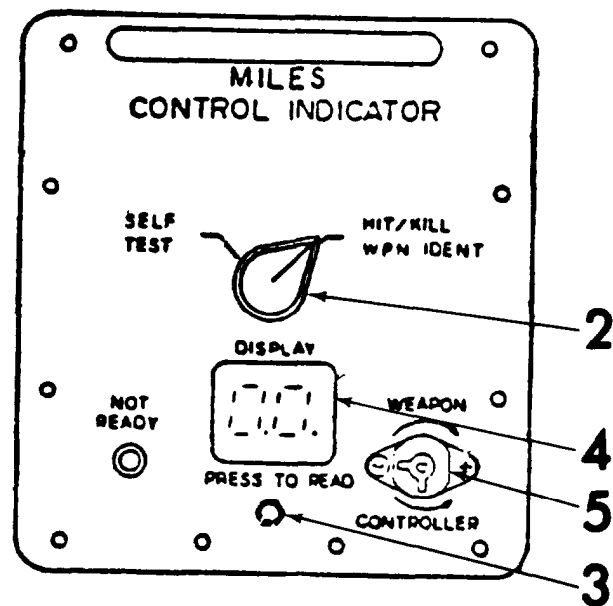

Operational Task 6: Recognizing Enemy Fire (Cont).

WARNING

Although the laser light emitted by MILES laser transmitters is considered eye safe by the Bureau of Radiological Health, suitable precautions must be taken to avoid possible eye damage from overexposure to this radiated energy. Precautionary measures include the following:

Avoid viewing laser emitter at close range (less than 12 meters). Increasing the eye-to-laser distance greatly reduces the risks of overexposure.

Avoid viewing emitter directly along optical axis of radiated beam.

Especially avoid viewing emitter through magnifying optics at engagement ranges of less than 75 meters for Stinger, Vulcan, and TOW, and 110 meters for the Chaparral.

Avoid allowing personnel with optics of higher transmission or magnifying power than normal tank optics to view Stinger, Vulcan, or TOW within 150 meters or the Chaparral within 330 meters.

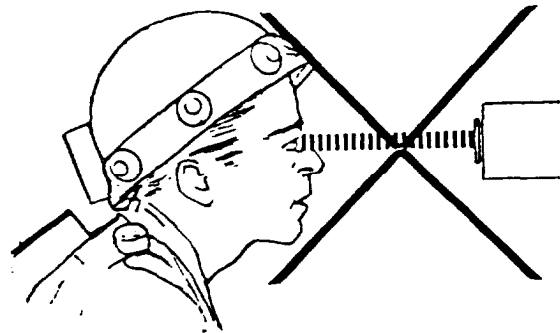
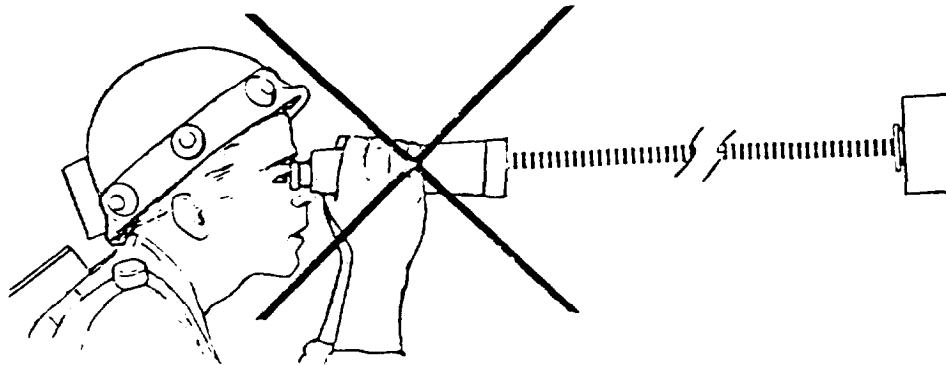

Operational Task 7: Resetting After a KILL.

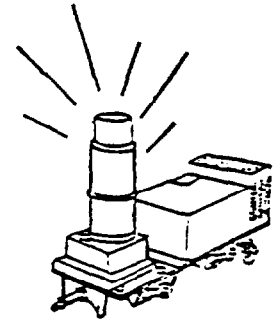
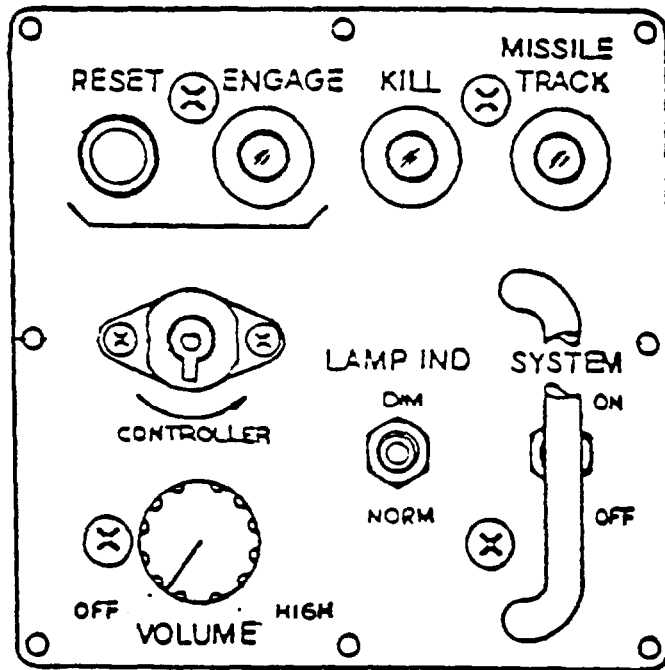

NOTE

If your helicopter is "KILLED," return to your base (unless otherwise instructed). Your OH-58/MILES system must be reset by the Controller and the spent smoke grenade replaced.

ENGAGE light on CKI may be reset any any time by pressing PUSH TO RESET button.

AKI strobe and KILL light on CKI must be reset by a Controller after helicopter lands.

WARNING

In inclement weather, you should shut off the AKI strobe to prevent experiencing vertigo during flight. AKI strobe is extinguished with circuit breaker for SIG LT RECT.

Operational Task 7: Resetting After a KILL (Cont).

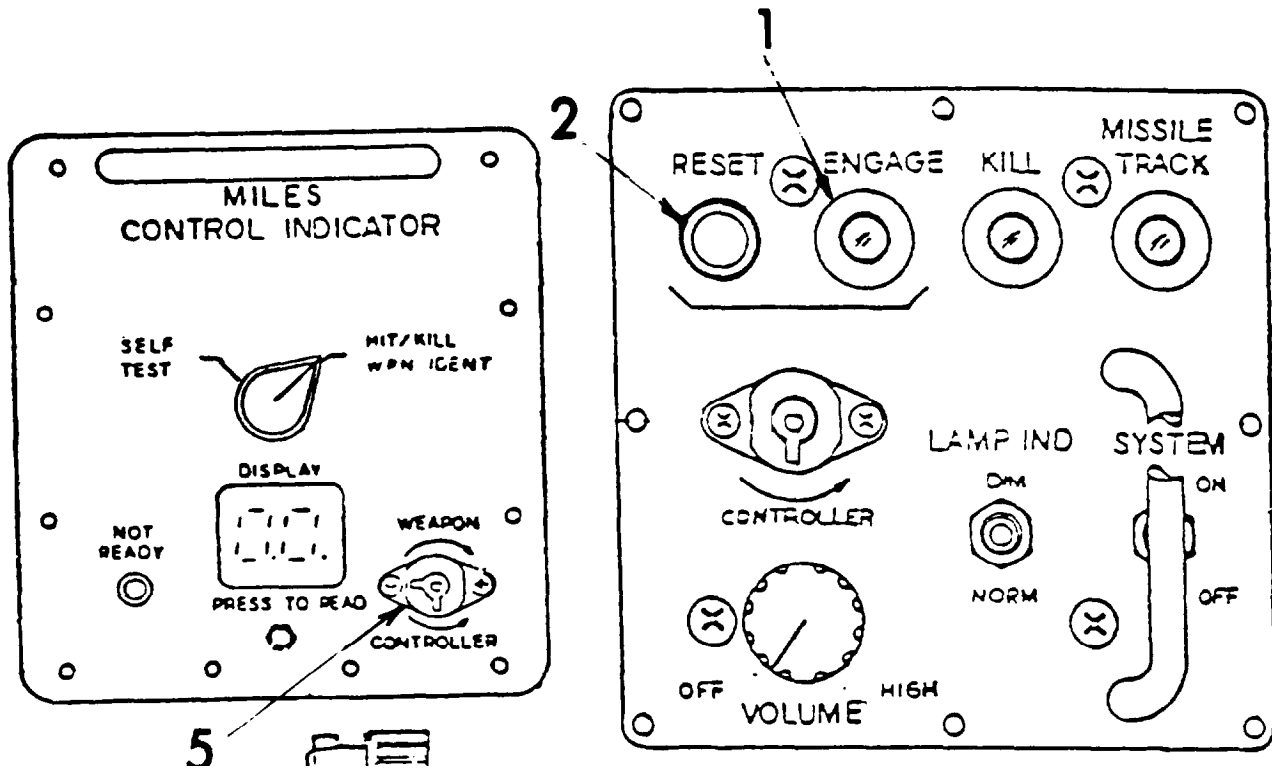

The Controller resets the system by inserting his Controller (green) key in receptacle (5) on ACIA or CKI, turning to CONTROLLER position momentarily, then removing key.

NOTE

If ENGAGE light (1) on CKI comes on when Controller resets system, depress RESET button (2) and ENGAGE light should extinguish.

WARNING

M18 Smoke Canisters are the ONLY canisters authorized for use with the AKI Smoke Assembly.

Care should be taken when handling expended canisters as they are initially hot to the touch

Failure to comply may result in Injury to Personnel

Remove and replace spent smoke grenade.

Have Controller check condition of batteries using MILES Systems Test Set

POSTOPERATIONAL TASKS - LIST

<u>Task</u>	<u>Title</u>	<u>Page</u>
1.	Inside Postoperational Task	2-79
2.	Outside Postoperational Task	2-80
3.	Transit Case Packing Instructions	2-81
4.	Return Equipment	2-81

Postoperational Task 1: Inside Postoperational Task,

Remove batteries from battery box. See Inside Installation Task 3 (Page 2-42).

Remove smoke grenade from smoke indicator. Dispose of grenade in accordance with local EOD procedures. See Operational Task 3 (Page 2-73).

Disconnect plugs from ACIA and battery box. Remove battery box/ACIA. Replace four screws and flat washers in cover on cargo platform. See Cabling Installation Task 7 and Inside Installation Task 3 (Pages 2-55 and 2-42).

Disconnect plugs from CKI. Remove CKI. Tighten two screws and nuts in center windshield retainer. See Cabling Installation Tasks 3 and 7. Inside Installation Task 5 (Pages 2-48, 2-55 and 2-44).

Disconnect plug from intercom cable. Release fastener tape straps from wire bundle at forward windshield. Disconnect plug from SIG LT RECP. Feed cable from crew compartment to center post. Remove W1 cable. Feed W3 cable down center post. Ensure that soundproofing blanket is secure over copilot's seat and on center post. See Cabling Installation Tasks 3 and 7 (Pages 2-48 and 2-55).

Postoperational Task 2: Outside Postoperational Task .

Disconnect W3 cable from W2 cable. Disconnect W3 cable from nose belt cable and two bottom belt cables. Remove W3 cable. See Cabling Installation Task 7 (Page 2-56).

Disconnect plugs at AKI and smoke indicator. Release fastener tape straps securing W2 cable to aft crosstube. Remove W2 cable. See Cabling Installation Task 5 (Page 2.52).

Remove Quick release pin from AKI/smoke. Loosen three jam nuts and withdraw three swivel screws. Remove AKI/smoke. See Outside Installation Task 12 (Page 2-38).

Disconnect top and bottom belt cable connectors. Unfasten four safety lanyards. Release tension in top and bottom belts. See Outside Installation Tasks 9 and 10 (Pages 2•34 and 2.36).

Disconnect bottom belts from rear harness assembly. Disconnect bottom belts from ring assembly. Remove bottom belts. See Outside Installation Tasks 7 and 8 (Pages 2•28 and 2•30).

Disconnect top belts from rear harness assembly. Disconnect top belts from nose belt. Remove top belts. See Outside Installation Tasks 5 and 6 (Pages 2-24 and 2-26).

NOTE

Do not remove fastener tape that is glued to helicopter

Unfasten rear harness safety lanyard. Remove rear harness assembly. See Outside Installation Tasks 4 and 9 (Pages 2-22 and 2-32).

Unfasten nose belt safety lanyards. Release tension in nose belt. Unfasten nose belt from ring assemblies. Remove nose belt. See Outside Installation Tasks 3 and 9 (Pages 2-18 and 2-32).

Remove ring assemblies from forward tiedown fittings. See Outside Preparation Task 2 (Page 2-10).

Postoperational Task 3: Transit Case Packing Instructions. Store MILES equipment in appropriate locations in transit case.

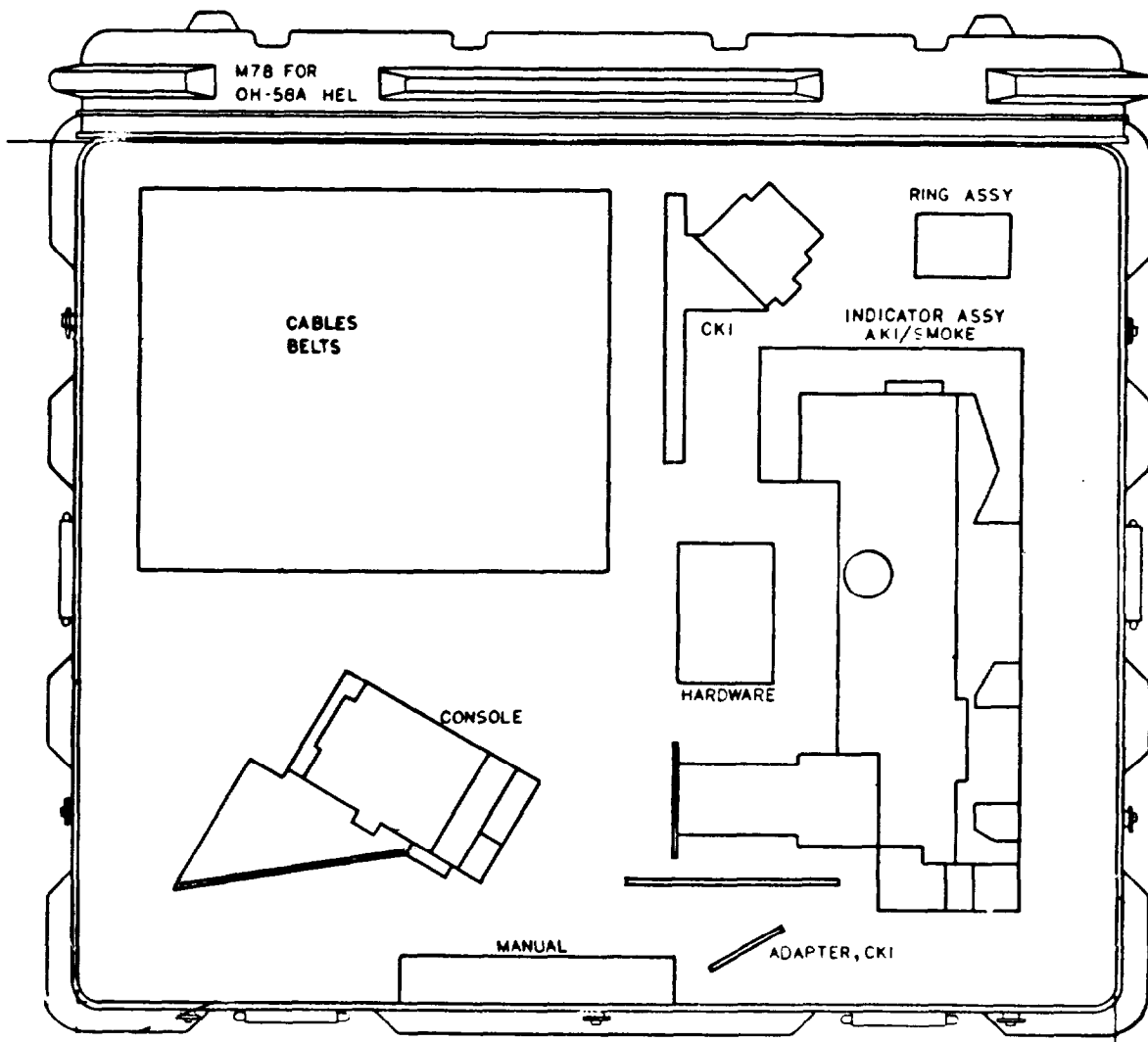

Postoperational Task 4: Return Equipment.

Include:

- MILES OH-58A transit case and equipment
- Unused M18 Smoke Grenades
- Authorized Materials

SECTION IV. OPERATION UNDER UNUSUAL CONDITIONS

Under unusual conditions, operational procedures for the MILES equipment have the same limitations as the OH-58 Observation Helicopter.

CHAPTER 3

MAINTENANCE INSTRUCTIONS

SECTION I. LUBRICATION INSTRUCTIONS

MILES equipment for the OH-58A/OH-58C helicopter requires no operator lubrication.

SECTION II. TROUBLESHOOTING PROCEDURES

Tables 3-1 and 3-2 list the common malfunctions which you may find during the operation or maintenance of the MILES simulator system for the OH-58 helicopter, or its components. You should perform the tests/inspections and corrective actions in the order listed.

Table 3-1 lists corrective actions by removing and replacing components,

Table 3-2 requires use of troubleshooting test equipment shown in figure 3-1.

This manual cannot list all malfunctions that may occur, nor all tests or inspections and corrective actions. If a malfunction is not listed or is not corrected by listed corrective actions, notify your supervisor.

Troubleshooting procedures in table 3-2 require the assistance of a Controller, a MILES System Test Set (MSTS) (Section II, Appendix C), and a Controller Gun (Section II, Appendix C).

The Controller will obtain, provide, and use this equipment. Crew members shall assist the Controller. Figure 3-2 is a component connection diagram and should be used as a reference.

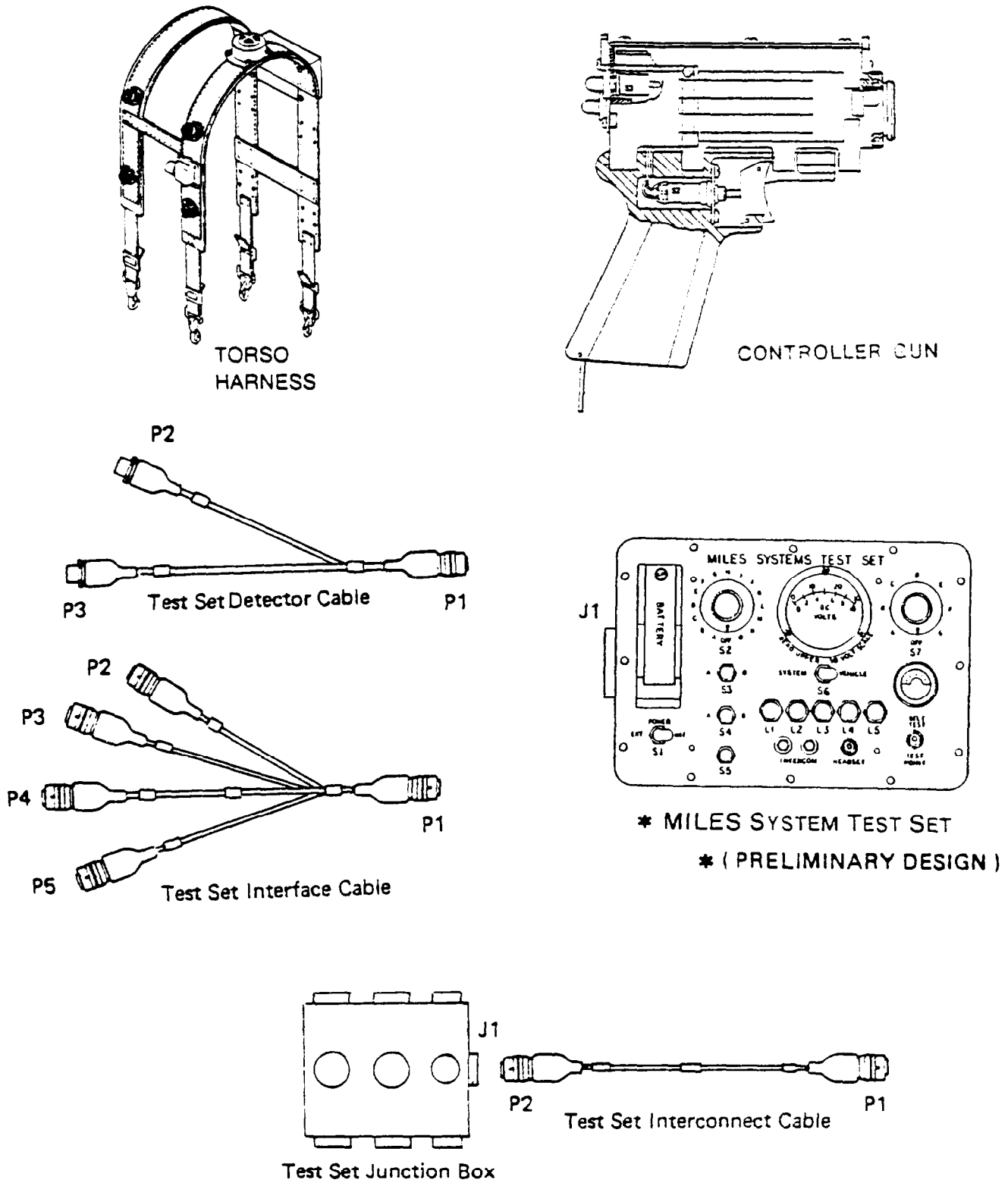

Figure 3-1, MILES OH-58 Helicopter Troubleshooting Equipment

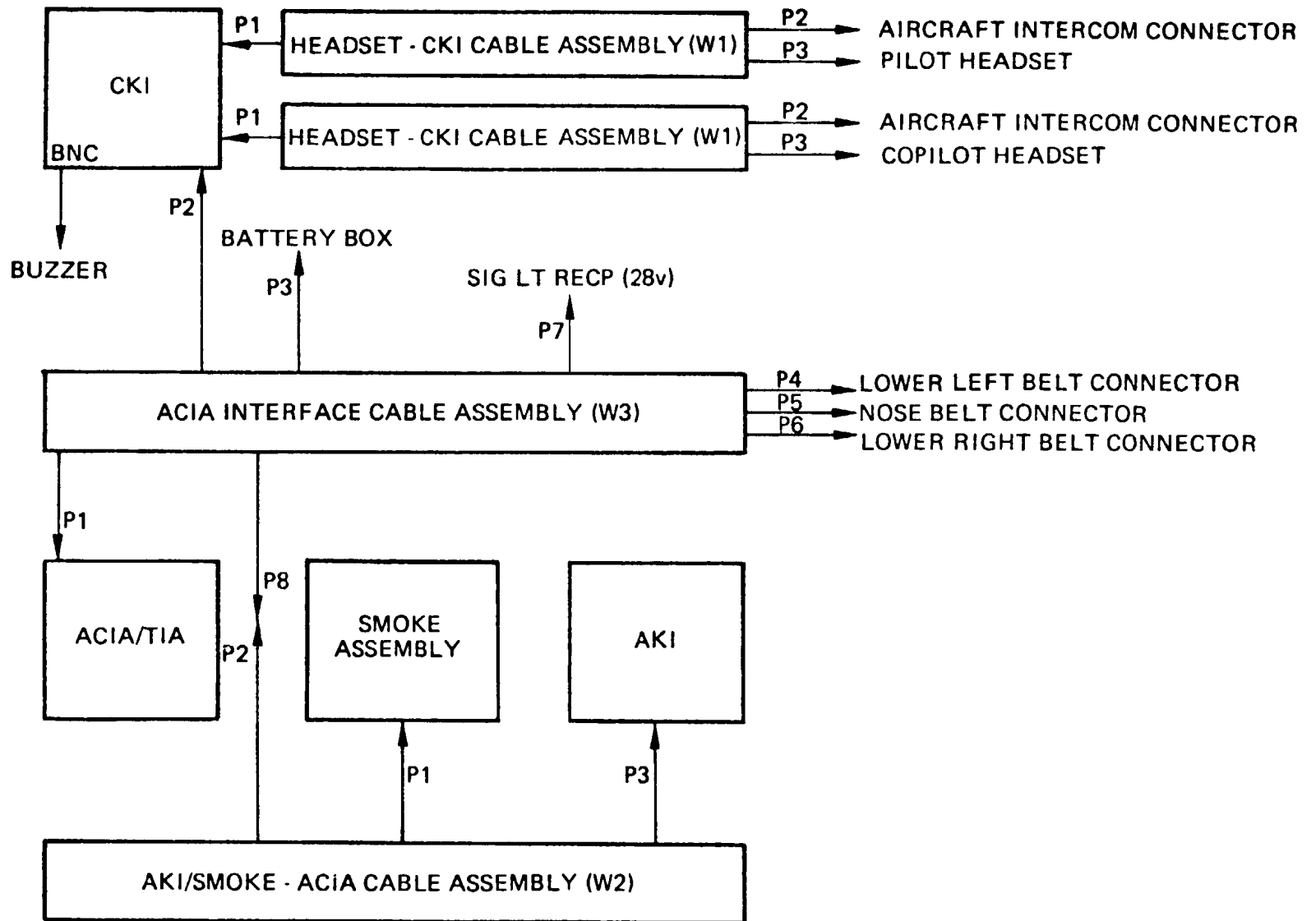

Figure 3-2. MILES OH-58 System Interconnect Diagram

WARNING

If task requires Vehicle Equipment Power to be turned ON, ensure Vehicle Equipment Power is turned OFF upon completion of task. Failure to comply may result in Personal Injury or Equipment Damage.

NOTE

If no Test Set is available go to Table 3-1 (below). If a MILES System Test Set (MSTS) is available. go to Table 3-2. page 3-13.

**Table 3-1. SYMPTOM INDEX
(NO TEST SET)**

<u>Unit</u>	<u>Symptom</u>	<u>Troubleshooting Procedure Page</u>
1. Aircraft Control Indicator Assembly (ACIA) Test	(1) Display Is Blank	3-5
	(2) Display Does Not Indicate 88	3-6
	(3) Weapon Identification Code Is Not Displayed	3-7
	(4) NOT READY Lamp Does Not Light	3-7
	(5) Display Indicates 33	3-7
2. Cockpit Kill Indicator (CKI) Test	(1) Any Indicator Lamp Does Not Light	3-8
	(2) KILL Lamp Does Not Light When System Is Killed And Smoke Assembly Operates	3-8
	(3) KILL Lamp Does Not Light When System Is Killed And Smoke Assembly Does Not Operate	3-8
	(4) ENGAGE Lamp Does Not Light	3-8
	(5) ENGAGE Lamp Does Not Reset	3-9
3. Smoke Assembly Test	(1) Smoke Assembly Inoperative	3-9
4. Aircraft Kill Indicator (AKI) Test	(1) AKI Inoperative With Correct CKI Lamp indication	3-10
	(2) AKI Inoperative With No CKI ENGAGE Lamp Indication	3-11
5. Aircraft Detector Assemblies Test	(1) Any One Detector Belt Fails	3-11
	(2) All Detector Belts Fail	3-12
6. Headset Test	(1) Headsets Fail	3-12

Table 3-1. Troubleshooting - No MILES System Test Set

MALFUNCTION	TEST OR INSPECTION	CORRECTIVE ACTION
-------------	--------------------	-------------------

NOTE

The following Troubleshooting procedures are common to all malfunctions listed. These should be performed before attempting procedures listed for each item of AGES/AD equipment.

Disconnect connector(s) from unit being tested. Wait one second and reconnect.

If malfunction is corrected, return system to service.

If unit still malfunctions disconnect Battery Box from ACIA Interface Cable Assembly (W3), connector P3. Wait one second and reconnect.

If malfunction is corrected, return system to service

If unit still malfunctions, remove battery from Battery Box. Replace with new battery

If malfunction is corrected, return system to service.

If unit still malfunctions remove Battery Box. Replace with Battery Box known to be usable. Insert new battery.

If malfunction is corrected, return system to service.

1. AIRCRAFT CONTROL INDICATOR ASSEMBLY (ACIA) TEST

(1) Display Is Blank

Place SYSTEM switch on CKI to OFF. Pause one second and place to ON. Check ACIA display.

If display indicates 00, return system to service.

If display is blank, remove ACIA. Replace with ACIA known to be operable. Check ACIA display.

If display indicates 00, return system to service.

If display is blank, reinstall former ACIA. Remove CKI. Replace with CKI known to be operable. Check ACIA display.

If display indicates 00, return system to service.

Table 3-1. Troubleshooting - No MILES System Test Set (Cont)

MALFUNCTION	TEST OR INSPECTION	CORRECTIVE ACTION
1. <u>AIRCRAFT CONTROL INDICATOR ASSEMBLY (ACIA) TEST (CONT)</u>	(1) Display Is Blank (Cont)	<p>If display is blank. reinstall former CKI. Remove ACIA Interface Cable Assembly (W3). Replace with cable assembly known to be usable. Check ACIA display.</p> <p>If display indicates 00, return system to service.</p> <p>If display is blank. reinstall former ACIA Interface Cable Assembly (W3). Each of the assemblies and cable assemblies listed below should be removed and replaced, ONE AT A TIME and IN THE ORDER LISTED. Check display reading between each removal and replacement.</p> <ol style="list-style-type: none"> a. NOSE DETECTOR BELT b. LOWER LEFT DETECTOR BELT c. LOWER RIGHT DETECTOR BELT d. AKI/SMOKE ASSEMBLY e. AKI/SMOKE-ACIA CABLE ASSEMBLY (W2) f. ACIA INTERFACE CABLE ASSEMBLY (W3) <p>If display indicates 00 during any step of the procedure. return system to service.</p> <p>If display still does not indicate 00, verify Aircraft Electrical System is operational.</p> <p>If electrical system is operational. return system to service.</p> <p>If electrical system is not operational, correct electrical system malfunction (refer to TM 55-1520-210-10). Return system to service.</p>
(2) Display Does Not Indicate 88	Failure of ACIA to display 88 indicates a malfunction of the ACIA.	Replace defective ACIA. Return system to service.

MALFUNCTION**TEST OR INSPECTION****CORRECTIVE ACTION**

(3) Weapon Identification Code Is Not Displayed

Failure of ACIA to display a Weapon Identification Code indicates a malfunction of the ACIA.

Replace defective ACIA. Return system to service

(4) NOT READY Lamp Does Not Light

Failure of NOT READY lamp to light when a KILL response is indicated by AKI/Smoke Assembly and CKI. indicates a malfunction of the ACIA.

Replace defective ACIA. Return system to service.

(5) Display Indicates 33

Place SYSTEM switch on CKI to OFF. Pause one second and place SYSTEM switch to ON.

Insert a Controller Key into Controller key receptacle on CKI. Turn counterclockwise to CONTROLLER position. Turn back and remove key.

Turn ACIA Select switch to HIT/KILL WPN IDENT, turn to SELF TEST. Check ACIA display.

If display indicates 88, return system to service

If display does not indicate 88, remove ACIA. Replace with ACIA known to be operable. Check ACIA display.

If display indicates 88, return system to service

If display does not indicate 88, reinstall former ACIA. Remove CKI. Replace with CKI known to be operable. Check display reading.

If display indicates 88, return system to service.

If display does not indicate 88, reinstall former CKI.

Replace defective ACIA Interface Cable Assembly (W3). Return system to service.

Table 3-1. Troubleshooting - No MILES System Test Set (Cont)

MALFUNCTION	TEST OR INSPECTION	CORRECTIVE ACTION
2. <u>COCKPIT KILL INDICATOR (CKI) TEST</u>		
(1) Any Indicator Lamp Does Not Light		<p>Momentarily depress each indicator lamp on CKI.</p> <p>If any indicator lamp fails to light, replace defective CKI. Return system to service.</p>
(2) KILL Lamp Does Not Light When System Is Killed And Smoke Assembly Operates		<p>Failure of the KILL lamp to light when Smoke Assembly is operating properly, indicates a malfunction of the CKI.</p> <p>Replace defective CKI. Return system to set-vice.</p>
(3) KILL Lamp Does Not Light When System Is Killed And Smoke Assembly Does Not Operate		<p>Remove CKI and replace with CKI known to be operational. Check KILL lamp.</p> <p>If KILL lamp lights, return system to service</p> <p>If KILL lamp does not light. reinstall former CKI. Remove ACIA. Replace with ACIA known to be operable. Check KILL lamp</p> <p>If KILL lamp lights. return system to service.</p> <p>If KILL lamp does not light, reinstall former ACIA.</p> <p>Replace defective ACIA Interface Cable Assembly (W3). Return system to service.</p>
(4) ENGAGE Lamp Does Not Light		<p>Remove CKI. Replace with CKI known to be operational. Check ENGAGE light.</p> <p>If ENGAGE lamp lights, return system to service.</p> <p>If ENGAGE lamp does not light, reinstall former CKI.</p> <p>Replace defective ACIA Interface Cable Assembly (W3). Return system to service.</p>

 MALFUNCTION

TEST OR INSPECTION

CORRECTIVE ACTION

 (5) ENGAGE Lamp Does Not Reset

Remove CKI. Replace with CKI known to be operational. Check ENGAGE lamp for reset.

If ENGAGE lamp resets. return system to service.

If ENGAGE lamp does not reset, reinstall former CKI. Remove ACIA. Replace with ACIA known to be operable. Check ENGAGE lamp for reset.

If ENGAGE lamp resets, return system to service.

If ENGAGE lamp does not reset, reinstall former CKI. Remove AKI. Replace with AKI known to be operable. Check ENGAGE lamp for reset.

If ENGAGE lamp resets, return system to service.

If ENGAGE lamp does not reset, reinstall former AKI. Remove AKI/Smoke-ACIA Cable Assembly (W2). Replace with cable assembly known to be usable. Check ENGAGE lamp for reset.

If ENGAGE lamp resets. return system to service

If ENGAGE lamp does not reset, reinstall former AKI/Smoke-ACIA Cable Assembly (W2).

Replace defective ACIA Interface Cable Assembly (W3). Return system to service.

3. SMOKE ASSEMBLY TEST

(1) Smoke Assembly Inoperative

Check the following:

ACIA Interface Cable Assembly (W3), connector P7, is properly connected to the Overhead Signal Light receptacle (SIG LT RECP).

BAT circuit breaker on overhead console switch is ON.

If Smoke Assembly does not operate. remove CKI. Replace with CKI known to be operable. Retest Smoke Assembly.

If assembly operates correctly (extractor is pulled into housing), return system to service.

Table 3-1. Troubleshooting - No MILES System Test Set (Cont)

MALFUNCTION	TEST OR INSPECTION	CORRECTIVE ACTION
-------------	--------------------	-------------------

3. SMOKE ASSEMBLY TEST (CONT)

(1) Smoke Assembly Inoperative (Cont)

If Smoke Assembly does not operate. reinstall former CKI. Remove Smoke Assembly. Replace with assembly known to be operable. Retest Smoke Assembly.

If assembly operates correctly, return system to service.

If Smoke Assembly does not operate. reinstall former Smoke Assembly. Remove AKI/Smoke-ACIA Cable Assembly (W2). Replace with cable assembly known to be usable. Retest Smoke Assembly.

If assembly operates correctly, return system to service.

If Smoke Assembly does not operate. reinstall former AKI/Smoke-ACIA Cable Assembly (W2). Remove ACIA Interface Cable Assembly (W3). Replace with cable assembly known to be usable. Retest Smoke Assembly.

If assembly operates correctly, return system to service.

If Smoke Assembly does not operate, reinstall former ACIA Interface Cable Assembly (W3). Verify Aircraft Electrical System is operational.

If electrical system is operational, return system to service.

If electrical system is not operational, correct electrical system malfunction (refer to TM 55-1520-210-10). Return system to service.

4. AIRCRAFT KILL INDICATOR (AKI) TEST

(1) AKI Inoperative With Correct CKI Lamp Indication

Check the following:

ACIA Interface Cable Assembly (W3), connector P7, is properly connected to the Overhead Signal Light receptacle (SIG LT RECP).

BAT circuit breaker switch is ON.

If AKI does not operate, remove AKI. Replace with AKI known to be operable. Retest AKI.

If AKI operates correctly, return system to service.

MALFUNCTION

TEST OR INSPECTION

CORRECTIVE ACTION

If AKI does not operate, reinstall former AKI. Remove ACIA Interface Cable Assembly (W3). Replace with cable assembly known to be operable. Retest AKI.

If AKI operates properly, return system to service

If AKI does not operate, reinstall former ACIA Interface Cable Assembly (W3). Remove AKI/Smoke-ACIA Cable Assembly (W2). Replace with cable assembly known to be usable. Retest AKI.

If AKI operates correctly, return system to service

If AKI does not operate, reinstall former AKI/Smoke-ACIA Cable Assembly (W2). Verify Aircraft Electrical System is operational.

If electrical system is operational, return system to service

If electrical system is not operational, correct electrical system malfunction (refer to TM 55-1520-210-10). Return system to service.

(2) AKI Inoperative With No CKI ENGAGE Lamp Indication

If AKI does not operate and CKI ENGAGE lamp does not light, remove ACIA. Replace with ACIA known to be operable. Retest AKI.

If AKI operates and CKI ENGAGE lamp lights, return system to service.

If AKI does not operate and CKI ENGAGE lamp does not light, reinstall ACIA.

Replace ACIA Interface Cable Assembly (W3). Return system to service

5. AIRCRAFT DETECTOR ASSEMBLIES TEST

(1) Any One Detector Belt Fails

If a detector belt fails, remove belt. Replace with belt known to be usable. Retest system.

If detector belt responds correctly, return system to service.

If detector belt still fails, reinstall former detector belt.

Replace defective ACIA Interface Cable Assembly (W3). Return system to service.

Table 3-1. Troubleshooting - No MILES System Test Set (Cont)

MALFUNCTION	TEST OR INSPECTION	CORRECTIVE ACTION
-------------	--------------------	-------------------

5. AIRCRAFT DETECTOR ASSEMBLIES TEST (CONT)

(2) All Detector Belts Fail

If all Detector Belts fail, each of the assemblies and cable assemblies listed should be removed and replaced. Each removal/replacement should be done ONE AT A TIME and IN THE ORDER LISTED. Retest system between each removal and replacement.

- a. NOSE DETECTOR BELT
- b. TOP LEFT DETECTOR BELT
- c. BOTTOM LEFT DETECTOR BELT
- d. TOP RIGHT DETECTOR BELT
- e. BOTTOM RIGHT DETECTOR BELT
- f. ACIA INTERFACE CABLE ASSEMBLY (W3)

6. HEADSET TEST

(1) Headset(s) Fail

Remove CKI. Replace with CKI known to be operable. Retest System.

If audio tone is heard, return system to service.

If no tone IS heard, reinstall former ACIA Interface Cable Assembly (W3). Remove Headset-CKI Cable Assembly (W1). Replace with cable assembly known to be usable. Retest system.

If audio tone is heard, return system to service.

If no tone IS heard. reinstall former Headset-CKI Cable Assembly (W1).

Replace aircraft headsets. Return system to service.

**Table 3-2. SYMPTOM INDEX
(MILES SYSTEM TEST SET)**

<u>Unit</u>	<u>Symptom</u>	<u>Troubleshooting Procedure Page</u>
1. Aircraft Control Indicator Assembly (ACIA) Test	(1) Display Is Blank	3-14
	(1.1) Display Is Blank-incorrect Voltage	3-16
	(1.2) Display is Blank-Belt/Cable Test	3-17
	(2) Display Does Not Indicate 88	3-18
	(3) Weapon Identification Code Is Not Displayed	3-19
	(4) NOT READY Lamp Does Not Light	3-19
	(5) Display Indicates 33	3-20
2. Cockpit Kill Indicator (CKI) Test	(1) Any indicator Lamp Does Not Light	3-23
	(2) KILL Lamp Does Not Light When System Is Killed And Smoke Assembly Operates	3-23
	(3) KILL Lamp Does Not Light When System Is Killed And Smoke Assembly Does Not Operate	3-23
	(4) ENGAGE Lamp Does Not Light	3-25
	(5) ENGAGE Lamp Does Not Reset	3-27
3. Smoke Assembly Test	(1) Smoke Assembly Inoperative	3-28
	(1.1) Smoke Assembly Inoperative-Correct Voltage	3-31
4. Aircraft Kill Indicator (AKI) Test	(1) AKI Inoperative With Correct CKI Lamp Indication	3-33
	(1.1) AKI Inoperative With Correct CKI Lamp Indication-Correct Voltage	3-35
	(2) AKI Inoperative With No CKI ENGAGE Lamp Indication	3-36
5. Aircraft Detector Assemblies Test	(1) Nose Detector Belt Fails	3-37
	(2) Top Detector Belts Fails	3-38
	(3) Bottom Detector Belt Fails	3-39
	(4) Top And Bottom Belts On Same Side Fail	3-39
	(5) All Detector Belts Fail	3-41
	(5.1) All Detector Belts Fail-Controller Gun Test	3-43
	(5.2) All Detector Belts Fail-Controller Gun Test-Nose	3-44
	(5.3) All Detector Belts Fail-Controller Gun Test-Left	3-45
6. Headset Test	(1) Headsets Fail	3-46
	(1.1) Headsets Fail-Audio Tone	3-48

Table 3-2. Troubleshooting - With MSTS

MALFUNCTION	TEST OR INSPECTION	CORRECTIVE ACTION
-------------	--------------------	-------------------

1. AIRCRAFT CONTROL INDICATOR ASSEMBLY (ACIA) TEST

(1) Display Is Blank

Place SYSTEM switch on CKI to OFF. Pause for one second. Place SYSTEM switch to ON. Check ACIA display.

If display indicates 00, return system to service.

If display is blank. disconnect ACIA Interface Cable Assembly (W3), connector P2, from CKI.

Connect Test Set Interconnect Cable. connector P1, to test set, connector J1. Connect Test Set Interconnect Cable, connector P2, to Test Set Junction Box, connector J1.

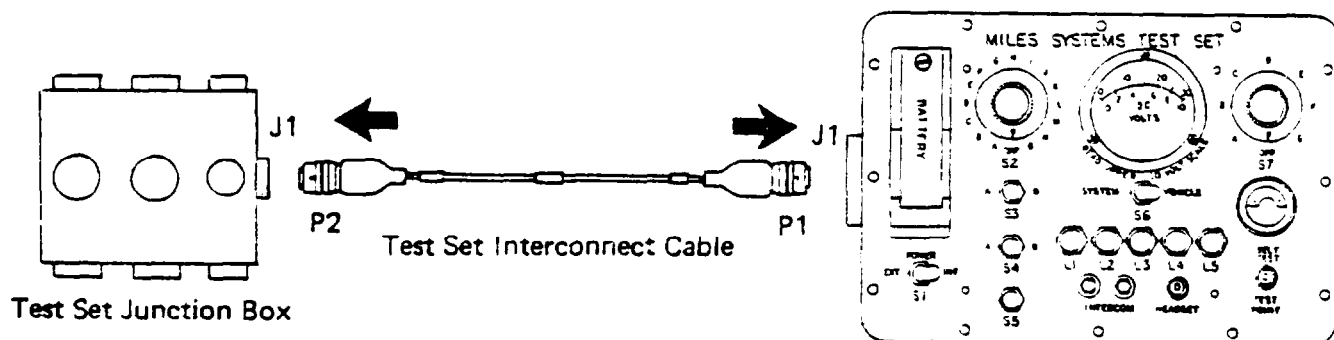

Connect ACIA Interface Cable Assembly (W3), connector P2, to connector J7 on Test Set Junction Box.

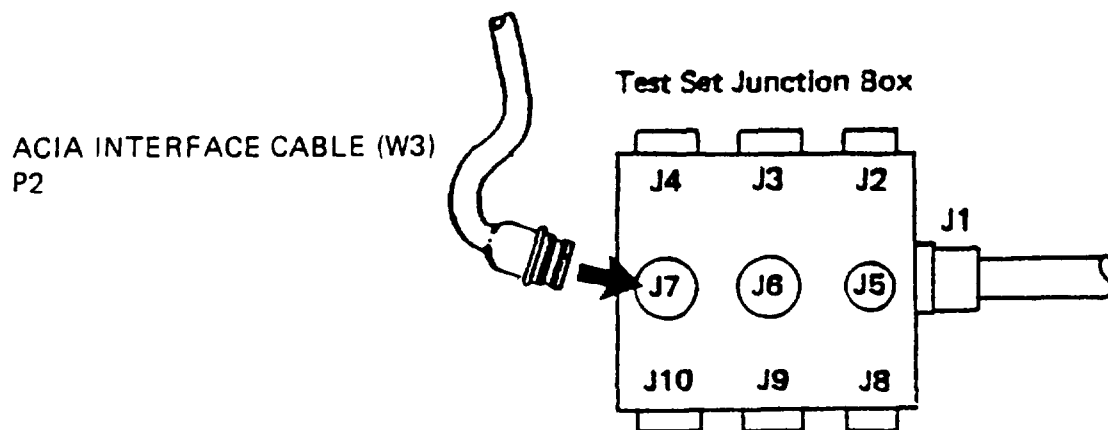

MALFUNCTION

TEST OR INSPECTION

CORRECTIVE ACTION

Place test set switch S1 to EXT.

Place test set switch S6 to SYSTEM.

Read voltage on voltmeter.

If voltage reading is less than 8.5 volts, proceed to (1.1) Display Is Blank - Incorrect Voltage.

If voltage is 8.5 to 13 volts. place test set switch S2 to 0. (Note that test set indicator lights L2 and L4 are ON. These indications do not affect troubleshooting procedures.)

Check ACIA display.

If display reads 00, replace defective CKI. Return system to service.

If display is still blank, disconnect ACIA Interface Cable Assembly (W3), from Test Set Junction Box. Reconnect to CKI.

Place test set switch S2 to OFF.

Disconnect ACIA Interface Cable Assembly (W3), connector P1 from ACIA. Connect to Test Set Junction Box Cable, connector J4.

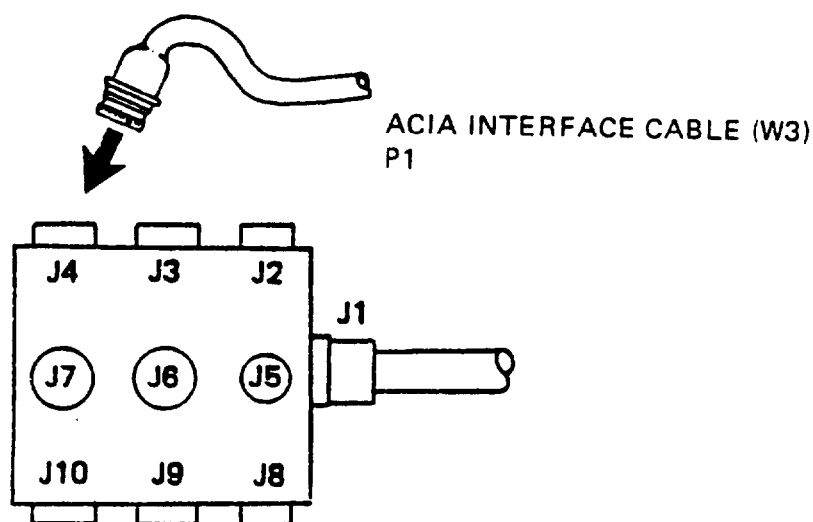

Verify SYSTEM switch on CKI is ON

Table 3-2. Troubleshooting - With MSTs (Cont)

MALFUNCTION	TEST OR INSPECTION	CORRECTIVE ACTION
-------------	--------------------	-------------------

1. AIRCRAFT CONTROL INDICATOR ASSEMBLY (ACIA) TEST (CONT)

(1) Display Is Blank (Cont)

Read voltage on voltmeter.

If voltage reading is 8.5 to 13 volts, replace defective ACIA. Return system to service.

If voltage reading is less than 8.5 volts. replace defective ACIA Interface Cable Assembly (W3). Return system to service.

(1-1) Display Is Blank - Incorrect Voltage

Disconnect ACIA Interface Cable Assembly (W3), from Test Set Junction Box. Disconnect Test Set Interconnect Cable from test set.

Connect Test Set Interface Cable, connector P1, to Test Set, connector J1.

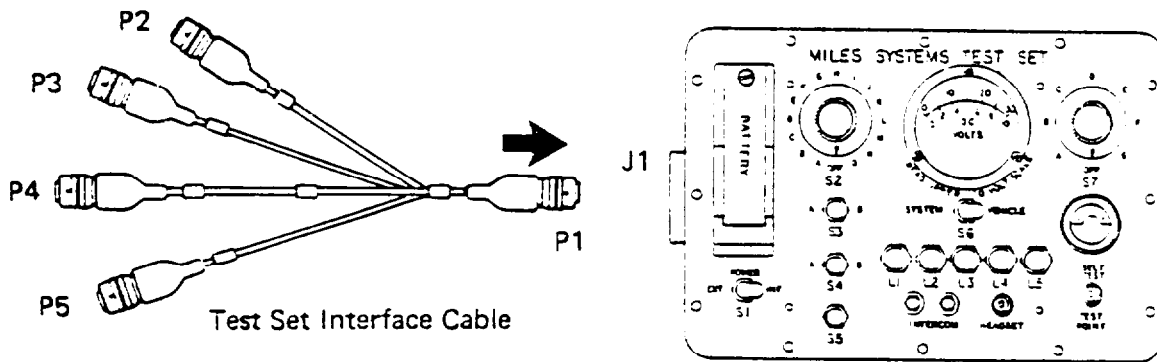

Disconnect ACIA Interface Cable Assembly (W3), from battery box. Connect battery box to Test Set Interface Cable, connector P4.

Place test set switch S6 to SYSTEM.

Read voltage on voltmeter.

If voltage reading is 8.5 to 13 volts, go to (1.2) Display Is Blank - Belt/Cable Test.

MALFUNCTION

TEST OR INSPECTION

CORRECTIVE ACTION

If voltage reading is less than 8.5 volts, install two new 6 V batteries in battery box.

Read voltage on voltmeter.

If voltage reading is 8.5 to 13 volts, discard old batteries. Return system to service.

If voltage reading is less than 8.5 volts, replace defective battery box. Return system to service.

(1.2) Display is Blank - Belt/Cable Test

Disconnect Test Set interface Cable from battery box. Reconnect to ACIA Interface Cable Assembly (W3). Disconnect Test Set Interface Cable from test set. Reconnect Test Set Interface Cable, connector P1, to test set, connector J1. Make sure Test Set Junction Box is still attached to cable.

Disconnect ACIA Interface Cable Assembly (W3), connector P1, from ACIA. Connect ACIA Interface Cable Assembly (W3), connector P1, to connector J4 on Test Set Junction Box.

Disconnect ACIA Interface Cable Assembly (W3), connector P5, from Nose belt connector. Check voltage on voltmeter.

If voltage reading is 8.5 to 13 volts, replace defective detector belt connector. Return system to service.

If voltage is less than 8.5 volts, reconnect Nose belt connector. Disconnect ACIA Interface Cable Assembly (W3), connector P6, from Lower Right belt connector. Check voltage on voltmeter.

If voltage reading is 8.5 to 13 volts, replace defective detector belt. Return system to service.

If voltage is less than 8.5 volts, reconnect Lower Right belt connector. Disconnect ACIA Interface Cable Assembly (W3), connector P4, from Lower Left belt connector. Check voltage on voltmeter.

If voltage reading is 8.5 to 13 volts, replace defective detector belt. Return system to service.

If voltage is less than 8.5 volts reconnect Lower Left belt connector. Disconnect ACIA Interface Cable Assembly (W3), connector P1 and AKI/Smoke-ACIA Cable Assembly (W2), connector P3. Check voltage on voltmeter.

Table 3-2. Troubleshooting - With MSTs (Cont)

MALFUNCTION	TEST OR INSPECTION	CORRECTIVE ACTION
-------------	--------------------	-------------------

AIRCRAFT CONTROL INDICATOR ASSEMBLY (ACIA) TEST (CONT)

(1.2) Display is Blank - Belt/Cable Test (Cont)

If voltage reading is 8.5 to 13 volts, replace defective AKI/Smoke Assembly. Return system to service.

If voltage is less than 8.5 volts reconnect ACIA Interface Cable Assembly (W3), to AKI/Smoke Assembly. Disconnect AKI/Smoke-ACIA Cable Assembly (W2), connector P2, from ACIA Interface Cable Assembly (W3), connector P8, Check voltage on voltmeter.

If voltage reading is 8.5 to 13 volts, replace defective AKI/Smoke-ACIA Cable Assembly (W2). Return system to service.

If voltage reading is less than 8.5 volts, replace defective ACIA Interface Cable Assembly (W3). Return system to service.

(2) Display Does Not indicate 88

Place SYSTEM switch on CKI to OFF. Pause one second. Place SYSTEM switch to ON.

Insert Controller Key into WEAPON Key receptacle on ACIA. Turn key counterclockwise to CONTROLLER position. Turn back and remove key.

Turn ACIA select switch to HIT/KILL. Then turn to SELF TEST. Check display.

If display reads 88, return system to service.

If display does not read 88, connect Test Set Interconnect Cable. connector P1, to Test Set. connector J1. Connect Test Set Interconnect Cable, connector P2, to Test Set Junction Box. connector J1.

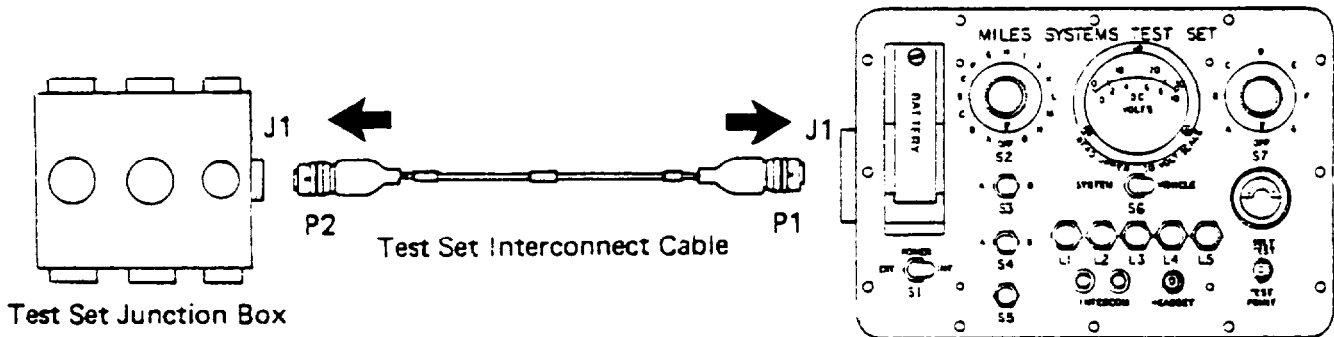

MALFUNCTION

TEST OR INSPECTION

CORRECTIVE ACTION

Disconnect ACIA Interface Cable Assembly (W3), connector P1, from ACIA. Connect to Test Set Junction Box, connector J4.

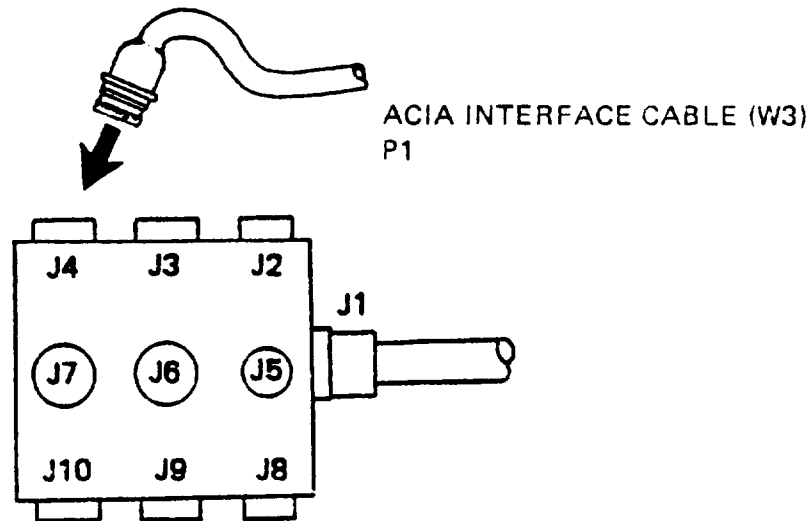

Place test set switch S6 to SYSTEM. Read voltage on voltmeter

If voltage reading is 8.5 to 13 volts, replace defective ACIA. Return system to service.

If voltage reading is less than 8.5 volts, discard old batteries. Install two new 6 V batteries. Return system to service.

(3) Weapon Identification Code Is Not Displayed

Failure of ACIA to display a Weapon Identification Code indicates a malfunction of the ACIA.

Replace defective ACIA. Return system to service.

(4) NOT READY Lamp Does Not Light

Failure of NOT READY lamp to light when a KILL response is being given by AKI, CKI, and Smoke Assembly, indicates a malfunction of the ACIA.

Replace defective ACIA. Return system to service

Table 3-2. Troubleshooting - With MSTs (Cont)

MALFUNCTION

TEST OR INSPECTION

CORRECTIVE ACTION

1. AIRCRAFT CONTROL INDICATOR ASSEMBLY (ACIA) TEST (CONT)

(5) Display Indicates 33

Place SYSTEM switch on CKI to OFF Pause one second. Place SYSTEM switch to ON.

Insert Controller Key into CONTROLLER Key receptacle on CKI. Turn counterclockwise to CONTROLLER position. Turn back and remove key.

Turn ACIA select switch to HIT/KILL WPN IDENT. Then turn to SELF TEST Check ACIA display.

If display reads 88, return system to service.

If display does not read 88, disconnect ACIA Interface Cable Assembly (W3), connector P2, from CKI.

Connect Test Set Interconnect Cable. connector P1, to test set, connector J1. Connect Test Set Interconnect Cable. connector P2, to Test Set Junction Box, connector J1.

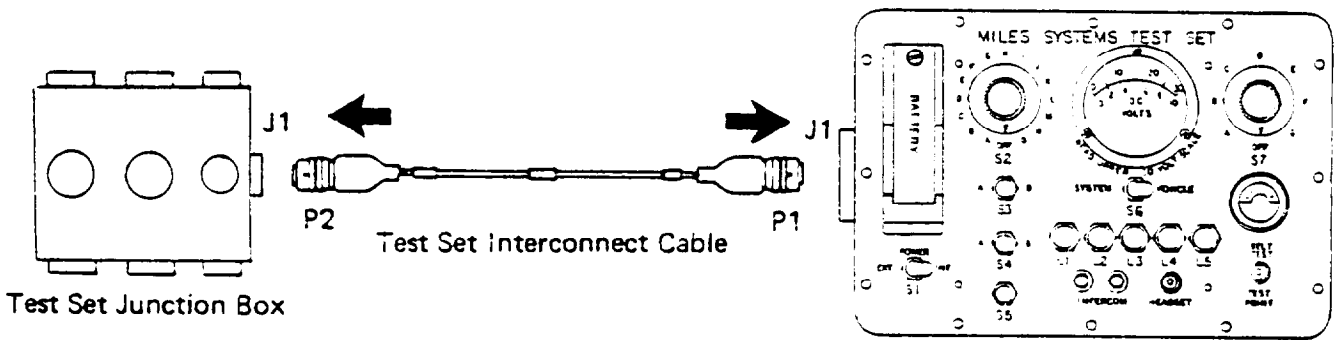

Place test set switch S1 to EXT.

Connect ACIA Interface Cable Assembly W3), connector P2, to Test Set Junction Box. connector J7.

MALFUNCTION

TEST OR INSPECTION

CORRECTIVE ACTION

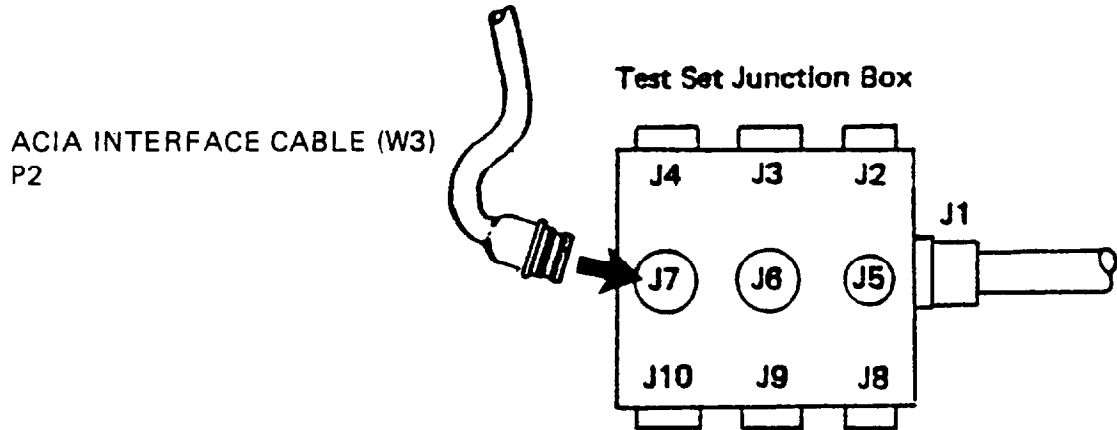

Place test set switch S2 to 0. (Note that test set indicator lights L2 and L4 may be ON. These indications have no effect on troubleshooting procedures.)

Insert Controller Key into WEAPON Key receptacle on ACIA. Turn key counterclockwise to CONTROLLER position. Turn back and remove key. Turn ACIA switch to HIT/KILL, then to SELF TEST. Check ACIA display.

If display reads 88, replace defective CKI. Return system to service

If display does not read 88, check test set indicator lamp 1-4.

If lamp L4 is ON, replace defective ACIA. Return system to service.

If lamp L4 does not light, disconnect ACIA Interface Cable Assembly (W3), from Test Set Junction Box. Reconnect to CKI.

Place test set switch S2 to OFF.

Table 3-2. Troubleshooting - With MSTS (Cont)

MALFUNCTION	TEST OR INSPECTION	CORRECTIVE ACTION
-------------	--------------------	-------------------

1. AIRCRAFT CONTROL INDICATOR ASSEMBLY (ACIA) TEST (CONT)

(5) Display Indicates 33 (Cont)

Disconnect ACIA Interface Cable Assembly (W3), connector P1, from ACIA. Connect to Test Set Junction Box, connector J4.

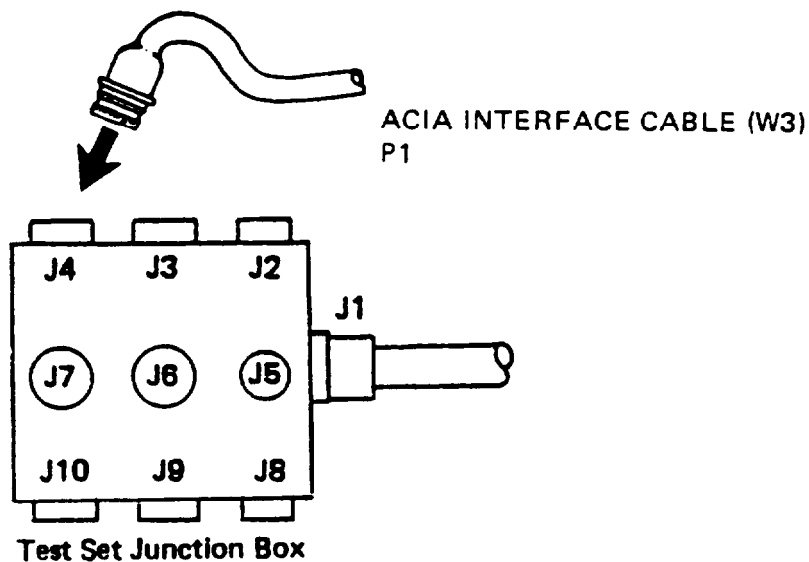

Place test set switch S7 to G. Depress test set switch S5. Check Indicator lamp L4.

If lamp L4 is ON, replace defective ACIA. Return system to service.

If lamp L4 is OFF, replace defective ACIA Interface Cable Assembly (W3). Return system to service.

MALFUNCTION

TEST OR INSPECTION

CORRECTIVE ACTION

2. COCKPIT KILL INDICATOR (CKI) TEST

(1) Any Indicator Lamp Does Not Light

Momentarily depress each indicator lamp on CKI.

If any indicator lamp does not light, replace defective CKI. Return system to service.

(2) KILL Lamp Does Not Light When System Is Killed And Smoke Assembly Operates

Failure of KILL lamp to light when Smoke Assembly is properly responding to a "KILL" indicates a malfunction of the CKI.

Replace defective CKI. Return system to service.

(3) KILL Lamp Does Not Light When System Is Killed And Smoke Assembly Does Not Operate

Connect Test Set Interconnect Cable, connector P1, to test set, connector J1. Connect Test Set Interconnect Cable, connector P2, to Test Set Junction Box, connector J1.

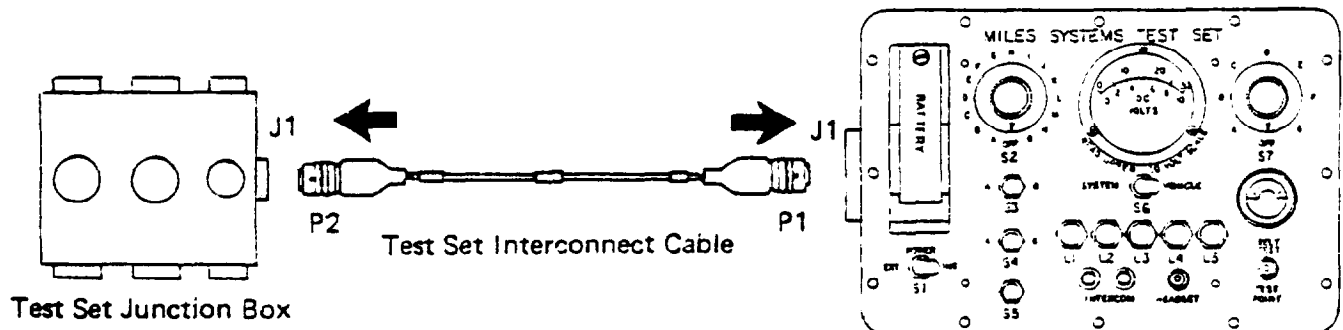

Place test set switch S1 to EXT.

Table 3-2. Troubleshooting - With MSTs (Cont)

MALFUNCTION	TEST OR INSPECTION	CORRECTIVE ACTION
-------------	--------------------	-------------------

2. COCKPIT KILL INDICATOR (CKI) TEST (CONT)

(3) KILL Lamp Does Not Light When System Is Killed And Smoke Assembly Does Not Operate (Cont)

Disconnect ACIA Interface Cable Assembly (W3), connector P2, from CKI. Connect to Test Set Junction Box. connector J7.

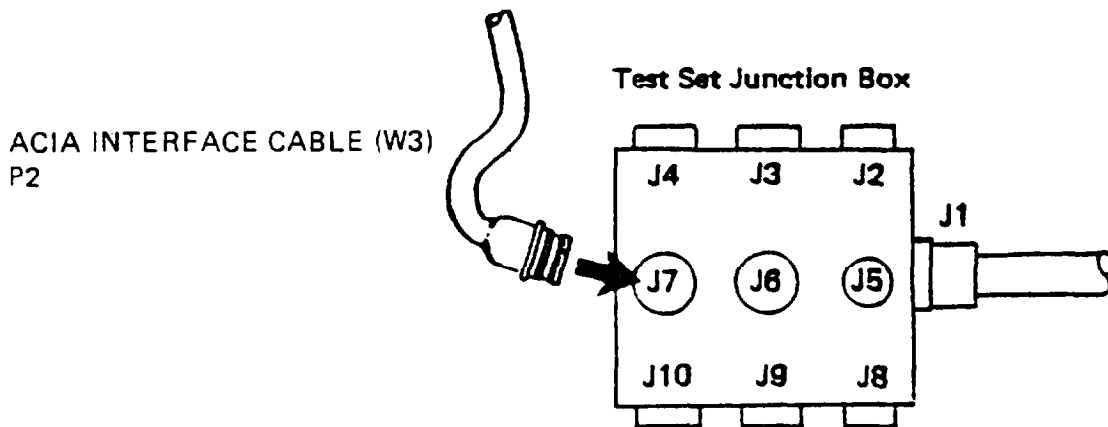

Place test set switch S2 to 0. (Note test set Indicator lamps L2 and L4 may be ON. These indications have no effect on troubleshooting procedures.)

Insert Controller Key into WEAPON Key receptacle on ACIA. Turn key counterclockwise to CONTROLLER position. Turn back and remove key.

Insert Vehicle (Orange) Key into WEAPON Key receptacle on ACIA. Turn key clockwise to "SELF KILL" system.

(Note test set Indicator lamp L4 may be ON and indicator lamp L2 may continuously flash ON/OFF. These indications have no effect on troubleshooting procedures.) Check indicator lamp L1.

If lamp L1 is ON. replace defective CKI. Return system to service

If lamp L1 does not light. disconnect ACIA Interface Cable Assembly (W3), from Test Set Junction Box. Reconnect to CKI.

Place test set switch S2 to OFF.

MALFUNCTION

TEST OR INSPECTION

CORRECTIVE ACTION

Disconnect ACIA interface Cable Assembly (W3), connector P1, from ACIA. Connect to Test Set Junction Box, connector J4.

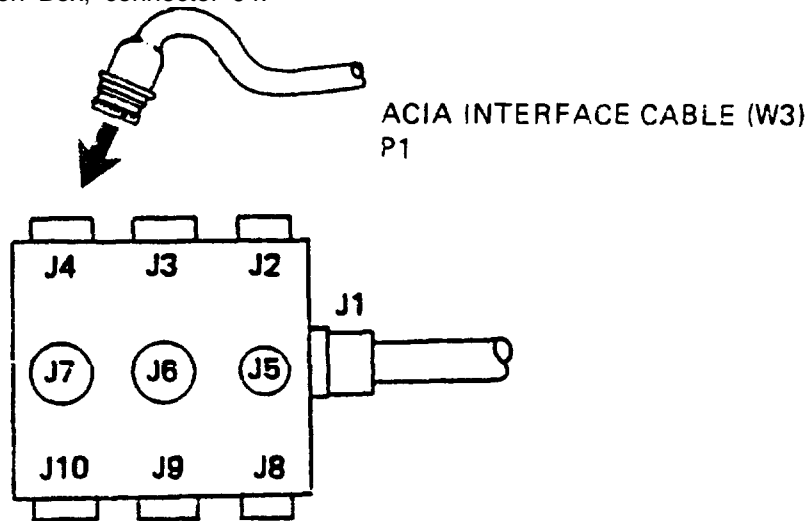

Place test set switch S7 to F. Depress test set switch S5. Check KILL lamp on CKI.

If KILL lamp comes ON, replace defective ACIA. Return system to service.

If KILL lamp does not light, replace defective ACIA Interface Cable Assembly (W3). Return system to service.

(4) ENGAGE Lamp Does Not Light

Connect Test Set Interconnect Cable, connector P1, to test set, connector J1. Connect Test Set Interconnect Cable, connector P2, to Test Set Junction Box, connector J1.

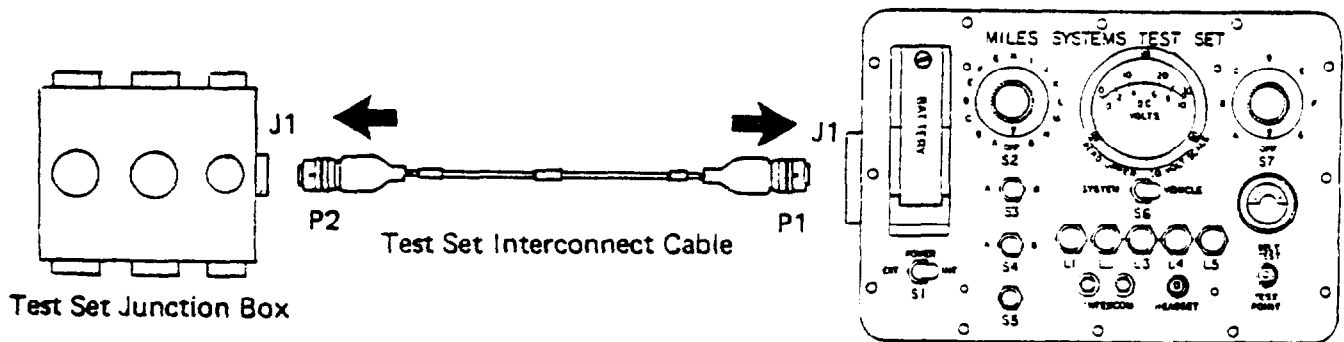

Table 3-2. Troubleshooting - With MSTS (Cont)

MALFUNCTION	TEST OR INSPECTION	CORRECTIVE ACTION
-------------	--------------------	-------------------

2. COCKPIT KILL INDICATOR (CKI) TEST (CONT)

(4) ENGAGE Lamp Does Not Light (Cont)

Disconnect ACIA Interface Cable Assembly (W3), connector P2, from CKI. Connect to Test Set Junction Box, connector J7.

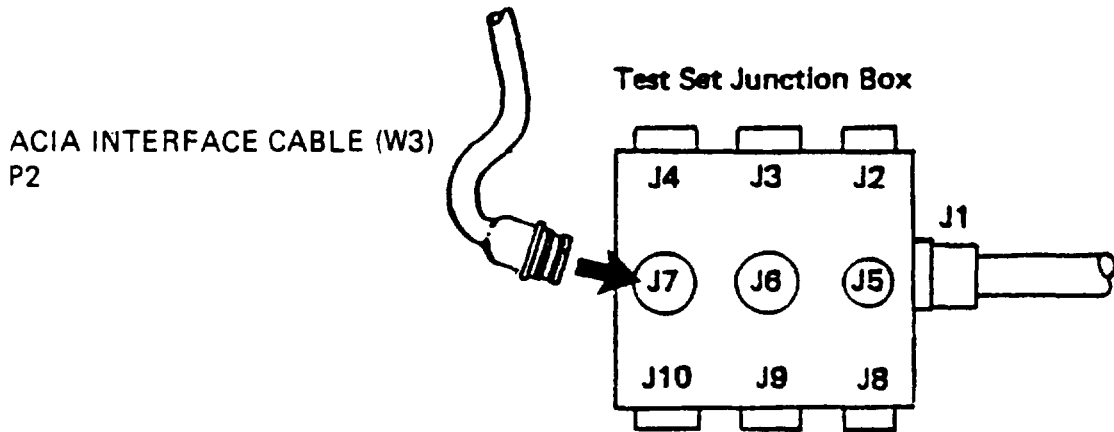

Place test set switch S2 to 0. (Note that test set indicator lamps L2 and L4 may be ON. These indications have no effect on troubleshooting procedures.)

Insert Controller Key into WEAPON Key receptacle on ACIA. Turn key counterclockwise to CONTROLLER position. Turn back and remove key.

Check test set indicator lamp L2.

If lamp L2 does not light, replace defective ACIA Interface Cable Assembly (W3). Return system to service.

If lamp L2 is ON, aim Controller Gun at detector belts. Fire a "NEAR-MISS" signal. Check test set indicator lamp L2.

If lamp L2 flashes ON/OFF, replace defective CKI. Return system to service.

If lamp L2 does not flash ON/OFF, replace defective ACIA Interface Cable Assembly (W3). Return system to service.

MALFUNCTION

TEST OR INSPECTION

CORRECTIVE ACTION

(5) ENGAGE Lamp Does Not Reset

Connect Test Set Interconnect Cable. connector P1, to Test Set, connector J1. Connect Test Set Interconnect Cable. connector P2, to Test Set Junction Box, connector J1.

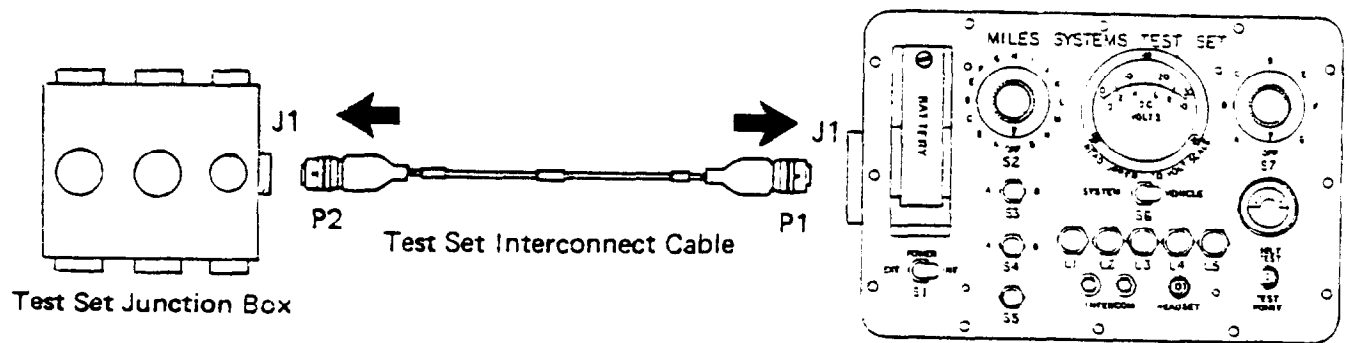

Place test set switch S1 to EXT.

Disconnect ACIA Interface Cable Assembly (W3), connector P2, from CKI. Connect to Test Set Junction Box, connector J7.

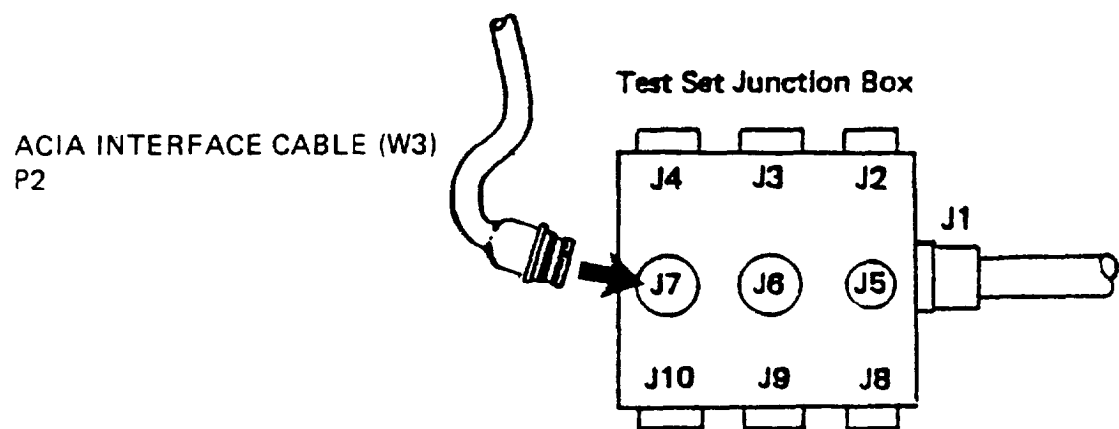

Place test set switch S2 to N. Check test set indicator lamp L2.

If lamp L2 is ON, replace defective CKI. Return system to service.

Table 3-2. Troubleshooting - With MSTs (Cont)

MALFUNCTION	TEST OR INSPECTION	CORRECTIVE ACTION
2. <u>COCKPIT KILL INDICATOR (CKI) TEST (CONT)</u>		
(5) ENGAGE Lamp Does Not Reset (Cont)		
	If lamp L2 does not light, disconnect AKI/Smoke-ACIA Cable Assembly (W2), connector P3, from AKI. Check test set indicator lamp L2.	if lamp L2 is ON, replace defective AKI. Return system to service
	If lamp L2 does not light. reconnect AKI/Smoke-ACIA Cable Assembly (W2), connector P3 to AKI. Disconnect AKI/Smoke-ACIA Cable Assembly (W2), connector P2, from ACIA Interface Cable Assembly (W3), connector P8. Check test set indicator lamp L2.	
		If lamp L2 is ON, replace defective AKI/Smoke-ACIA Cable Assembly (W2). Return system to service.
	If lamp L2 does not light. reconnect AKI/Smoke-ACIA Cable Assembly (W2), connector P2, to ACIA Interface Cable Assembly (W3). Disconnect ACIA Interface Cable Assembly (W3), connector P1, from ACIA. Check test set indicator lamp L2.	
		If lamp L2 is ON, replace defective ACIA. Return system to service.
		If lamp L2 does not light, replace defective ACIA Interface Cable Assembly (W3). Return system to service.
3. <u>SMOKE ASSEMBLY TEST</u>		
(1) Smoke Assembly Inoperative		
	Before proceeding check that:	
	ACIA Interface Cable Assembly (W3), connector P7, is connected to Overhead Signal Light Receptacle (SIG LT RECP) located on overhead console.	
		BAT circuit breaker switch on overhead console is ON

MALFUNCTION

TEST OR INSPECTION

CORRECTIVE ACTION

Connect Test Set Interconnect Cable, connector P1, to test set, connector J1. Connect Test Set Interconnect Cable, connector P2, to Test Set Junction Box, connector J1.

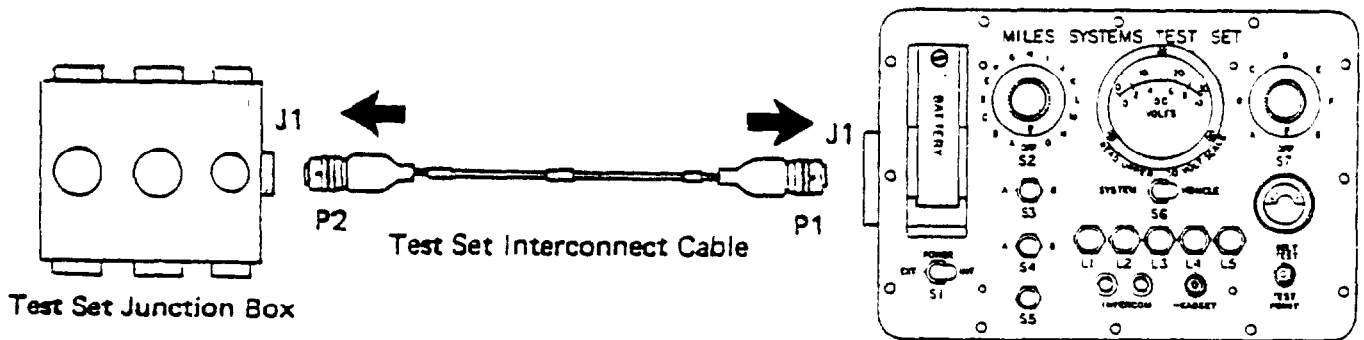

Place test set switch S1 to INT.

Install a 9 V battery in test set battery box.

Disconnect AKI/Smoke-ACIA Cable Assembly (W2), connector P1, from Smoke Assembly Connect to Test Set Junction Box, connector J5.

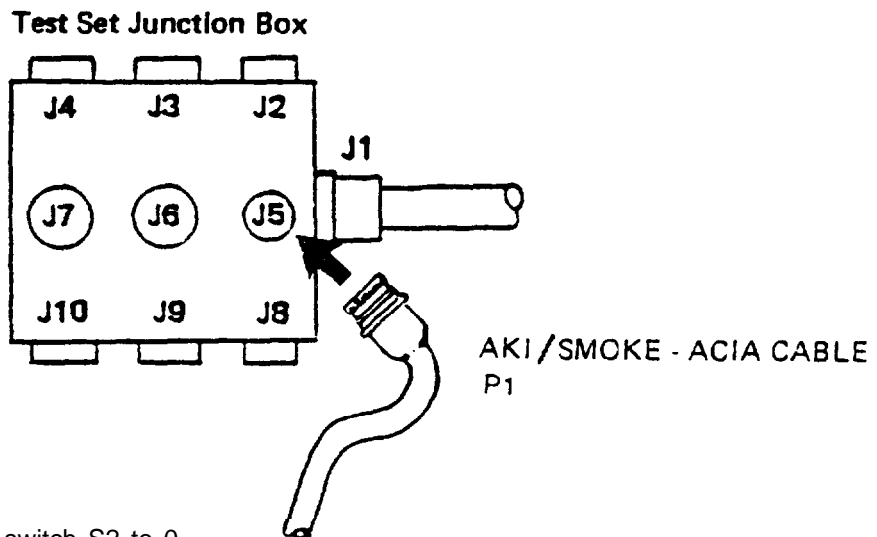

Place test set switch S2 to 0.

Place test set switch S6 to VEHICLE.

Table 3-2. Troubleshooting - With MSTs (Cont)

MALFUNCTION	TEST OR INSPECTION	CORRECTIVE ACTION
-------------	--------------------	-------------------

3. SMOKE ASSEMBLY TEST (CONT)

(1) Smoke Assembly Inoperative (Cont)

Read voltage on voltmeter.

If voltage reading is 20 to 30 volts, proceed to (1.1) Smoke Assembly Inoperative - Correct Voltage.

If voltage reading is less than 20 volts, check aircraft electrical system. (Refer to TM 55-1520-235-10 or TM 55-1520-228-10.) Repair all malfunctions. Return system to service.

If there is no voltage indicated on voltmeter, disconnect AKI/Smoke-ACIA Cable Assembly (W2), from Test Set Junction Box. Reconnect to Smoke Assembly.

Disconnect ACIA Interface Cable Assembly (W3), connector P8, from AKI/Smoke-ACIA Cable Assembly (W2), connector P2. Connect P8 to Test Set Junction Box. connector J5.

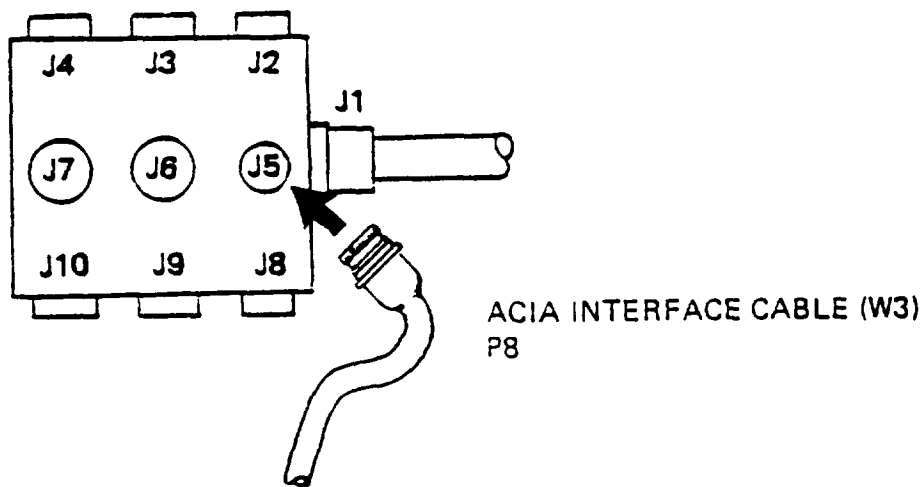

Read voltage on voltmeter

If voltage reading is 20 to 30 volts, replace defective AKI/Smoke-ACIA Cable Assembly (W2). Return system to service.

MALFUNCTION

TEST OR INSPECTION

CORRECTIVE ACTION

If voltage reading is less than 20 volts, verify aircraft electrical system is operational (Refer to TM 55-1520-235-10 or TM 55-1520-228-10)

If electrical system is not operational, correct all malfunctions. Return unit to service.

If electrical system is operational. replace defective ACIA Interface Cable Assembly (W3). Return unit to service.

(1-1) Smoke Assembly Inoperative - Correct Voltage

Place test set switch S7 to G.

Insert Vehicle (Orange) Key into WEAPON Key receptacle on ACIA. Turn key clockwise to WEAPON position.

Check test set indicator light L3.

If lamp L3 is ON, replace defective Smoke Assembly Return system to service.

If lamp L3 does not light, disconnect AKI/Smoke-ACIA Cable Assembly (W2), from Test Set Junction Box. Reconnect to Smoke Assembly.

Disconnect ACIA Interface Cable Assembly (W3), connector P8, from AKI/Smoke-ACIA Cable Assembly (W2), connector P2. Connect P8 to Test Set Junction Box, connector J5.

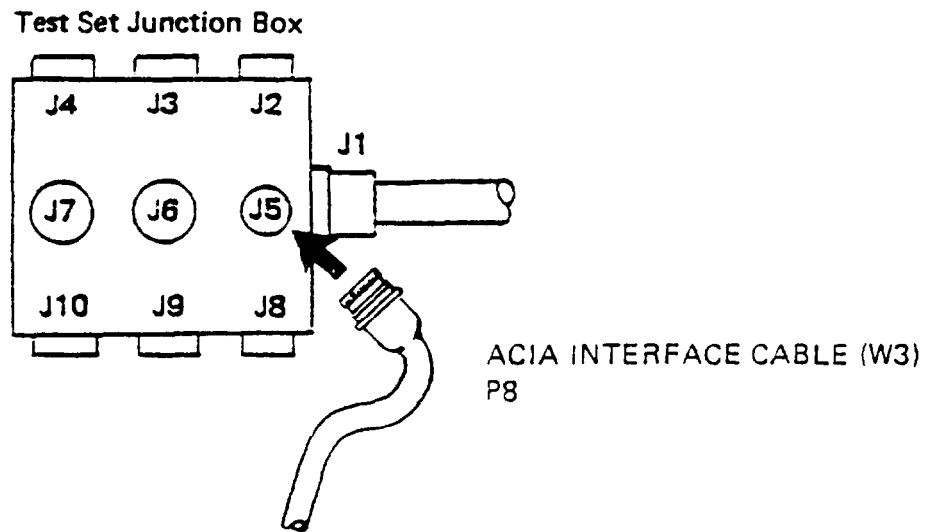

Table 3-2. Troubleshooting - With MSTS (Cont)

MALFUNCTION	TEST OR INSPECTION	CORRECTIVE ACTION
-------------	--------------------	-------------------

3. SMOKE ASSEMBLY TEST (CONT)

(1.1) Smoke Assembly Inoperative - Correct Voltage (Cont)

Check test set indicator light L3.

If lamp L3 is ON, replace defective AKI/Smoke-ACIA Cable Assembly (W2). Return system to service.

If lamp L3 does not light, disconnect ACIA Interface Cable Assembly (W3), from Test Set Junction Box. Reconnect to AKI/Smoke-ACIA Cable Assembly (W2).

Place test set switch S1 to EXT.

Place test set switch S2 to OFF.

Disconnect ACIA Interface Cable Assembly (W3), connector P2, from CKI. Connect to Test Set Junction Box, connector J7.

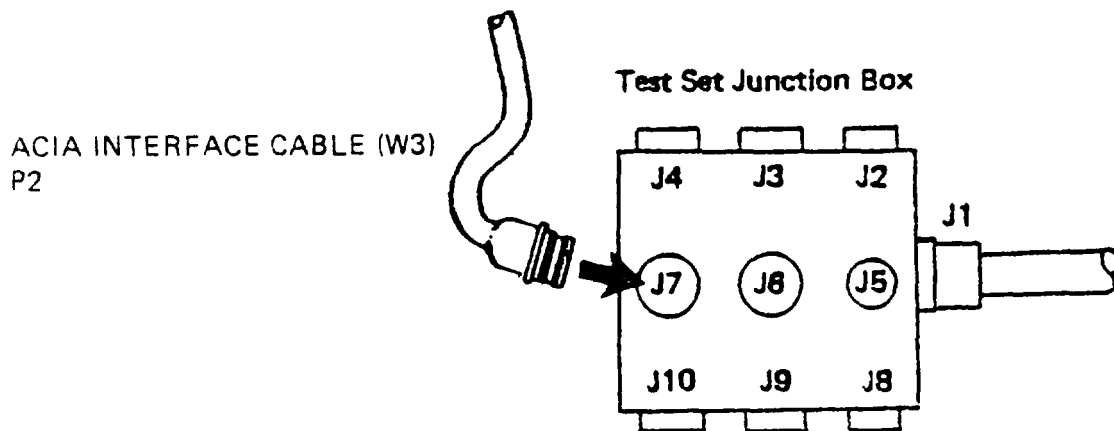

Place test set switch S7 to F. Momentarily depress test set switch S5. Check Smoke Assembly.

If Smoke Assembly extractor shaft moves into smoke indicator housing. replace defective CKI. Return return system to service.

If Smoke Assembly extractor shaft does not move, replace ACIA Interface Cable Assembly (W3), Return system to service.

MALFUNCTION

TEST OR INSPECTION

CORRECTIVE ACTION

4. AIRCRAFT KILL INDICATOR (AKI) TEST

(1) AKI Inoperative With Correct CKI Lamp Indication

Before proceeding check that:

ACIA Interface Cable Assembly (W3), connector P7, is connected to Overhead Signal Light Receptacle (SIG LT RECPT) located on overhead console.

BAT circuit breaker switch on overhead console is ON.

Connect Test Set Interconnect Cable, connector P1, to test set, connector J1. Connect Test Set Interconnect Cable, connector P2, to Test Set Junction Box, connector J1.

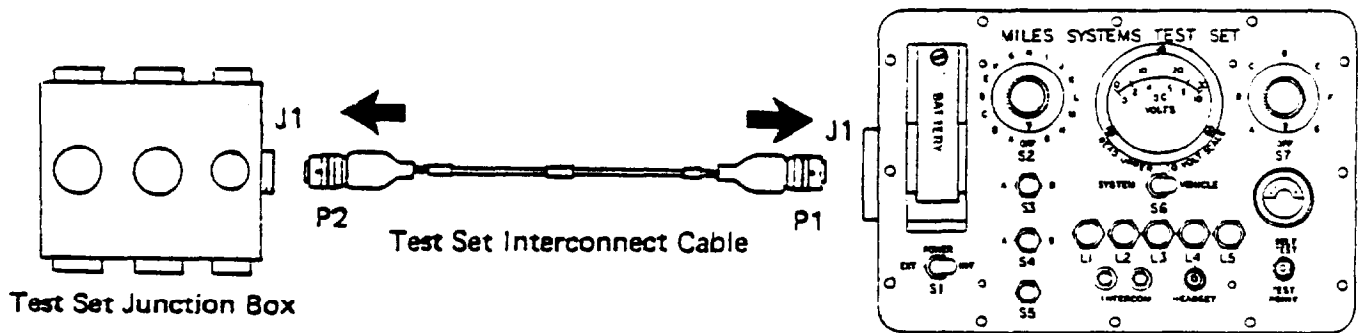

Place test set switch S1 to INT position.

Install a 9 V battery in test set battery box.

Disconnect AKI/Smoke-ACIA Cable Assembly (W2), connector P3, from AKI Assembly. Connect to Test Set Junction Box, connector J5.

Test Set Junction Box

Table 3-2. Troubleshooting - With MSTs (Cont)

MALFUNCTION	TEST OR INSPECTION	CORRECTIVE ACTION
-------------	--------------------	-------------------

4. AIRCRAFT KILL INDICATOR (AKI) TEST (CONT)

(1) AKI Inoperative With Correct CKI Lamp Indication (Cont)

Place test set switch S2 to 0.

Place test set switch S6 to VEHICLE.

Read voltage on voltmeter.

If voltage reading is 20 to 30 volts proceed to (1.1) AKI Inoperative With Correct CKI Lamp Indication - Correct Voltage.

If voltage reading is less than 20 volts, check aircraft electrical system for proper operation, (Refer to TM 55-1520-228-10 or TM 55-1520-235-10.) Correct all malfunctions. Return unit to service.

If voltmeter indicates no voltage, disconnect AKI/Smoke-ACIA Cable Assembly (W2) from Test Set Junction Box. Reconnect to AKI Assembly.

Disconnect ACIA Interface Cable Assembly (W3), connector P8, from AKI/Smoke-ACIA Cable Assembly (W2), connector P2. Connect to Test Set Junction Box, connector J5.

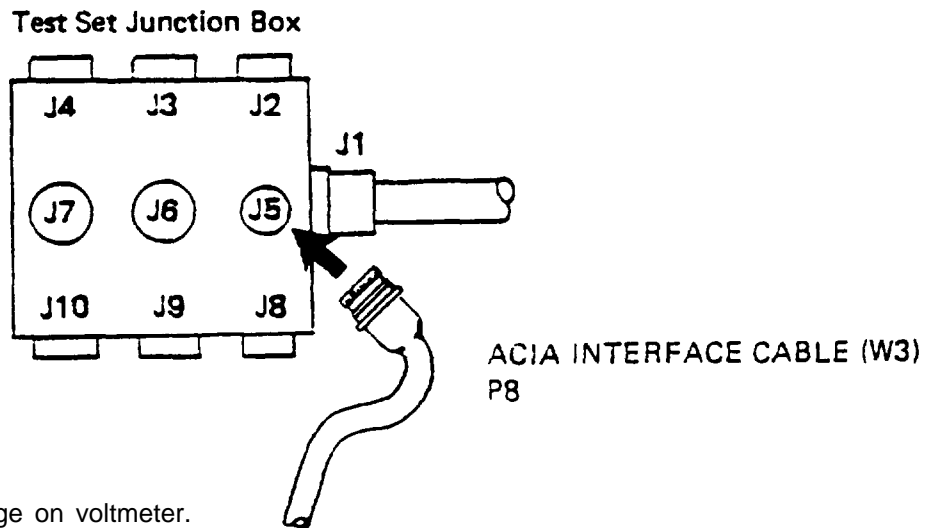

Read voltage on voltmeter.

If voltage reading is 20 to 30 volts, replace defective AKI/Smoke-ACIA Cable Assembly (W2). Return system to service.

If voltage reading is less than 20 volts, verify aircraft electrical system is operational.

MALFUNCTION

TEST OR INSPECTION

CORRECTIVE ACTION

If aircraft electrical system is inoperative, correct ail malfunctions. (Refer to TM 55-1520-228-10 and/or TM 55-1520-235-10). Return unit to service.

If aircraft electrical system has no malfunctions, replace ACIA Interface Cable Assembly (W3). Return system to service.

(1.1) AKI Inoperative With Correct CKI Lamp Indication - Correct Voltage

Turn test set switch S6 to E.

Insert Vehicle (Orange) Key into WEAPON Key receptacle on ACIA. Turn key clockwise to WEAPON Position.

Check test set indicator lamp L2.

If lamp L2 flashes ON/OFF, replace defective AKI Assembly. Return system to service.

If lamp L2 does not flash ON/OFF, disconnect AKI/Smoke-ACIA Cable Assembly (W2), from Test Set Junction Box Reconnect to AKI Assembly.

Disconnect ACIA Interface Cable Assembly (W3), connector P8, from AKI/Smoke-ACIA Cable Assembly (W2), connector P2. Connect P8 to Test Set Junction Box, connector J5.

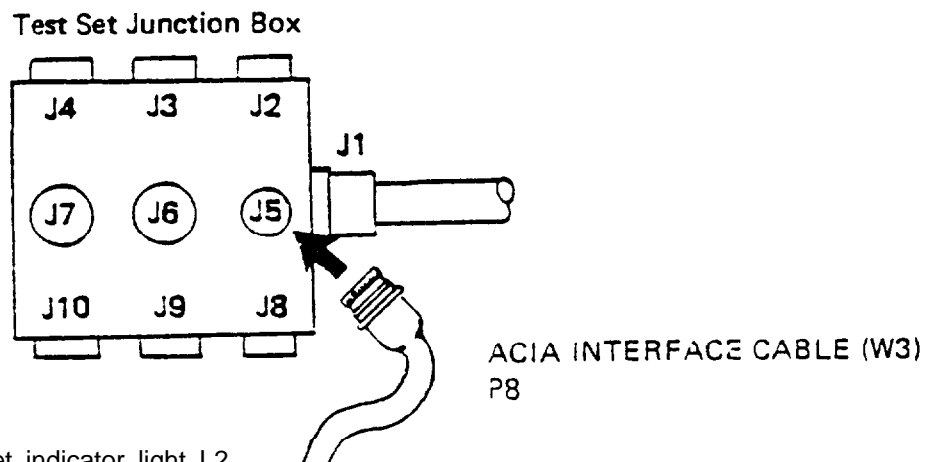

Check test set indicator light L2.

If light L2 flashes ON/OFF, replace defective AKI/Smoke-ACIA Cable Assembly (W2). Return system to service.

If light L2 does not flash ON/OFF. replace defective ACIA Interface Cable Assembly (W3). Return system to service.

Table 3-2. Troubleshooting - With MSTs (Cont)

MALFUNCTION	TEST OR INSPECTION	CORRECTIVE ACTION
-------------	--------------------	-------------------

4. AIRCRAFT KILL INDICATOR (AKI) TEST (CONT)

(2) AKI Inoperative With No CKI ENGAGE Lamp Indication

Connect Test Set Interconnect Cable, connector P1, to test set, connector J1. Connect Test Set Interconnect Cable, connector P2, to Test Set Junction Box, connector J1.

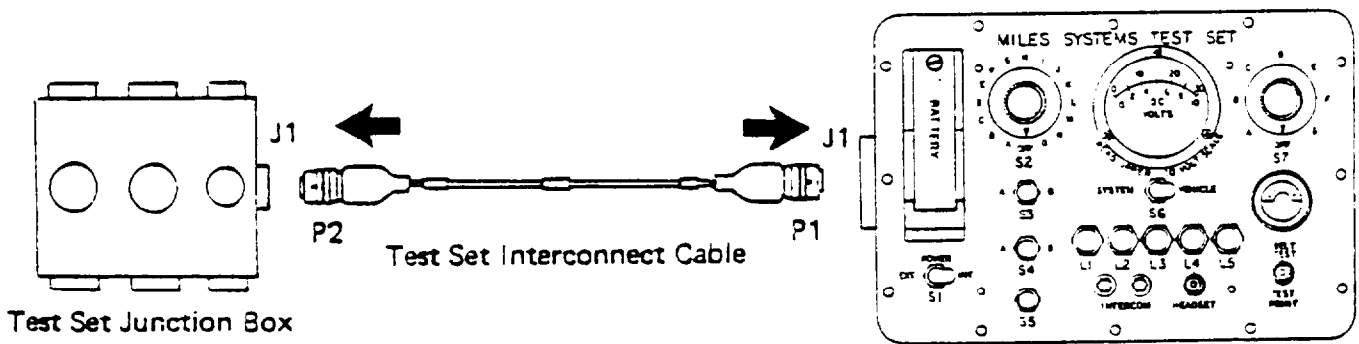

Place test set switch S1 to EXT.

Disconnect ACIA Interface Cable Assembly (W3), connector P1, from ACIA. Connect to Test Set Junction Box. connector J4.

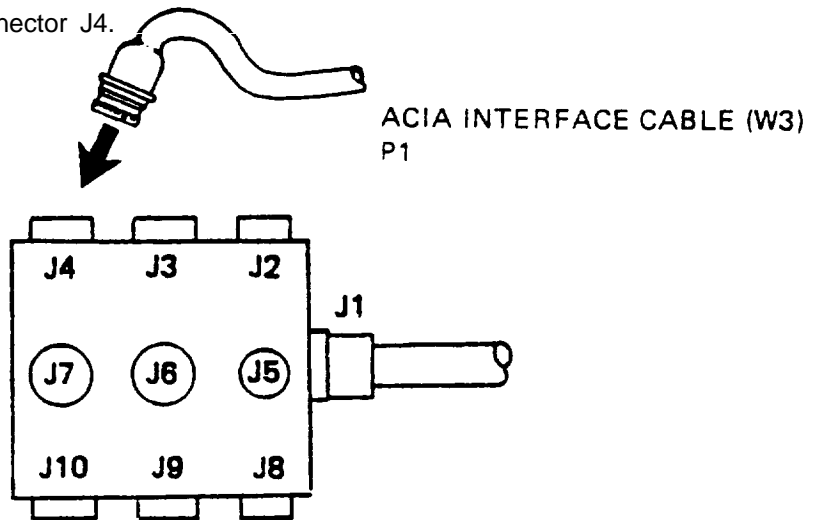

Place test set switch S7 to G. Momentarily depress and release switch S5. Check AKI.

If AKI flashes, replace defective ACIA. Return system to service.

If AKI does not flash, replace ACIA Interface Cable Assembly (W3). Return system to service.

MALFUNCTION

TEST OR INSPECTION

CORRECTIVE ACTION

5. AIRCRAFT DETECTOR ASSEMBLIES TEST

NOTE

If a BOTTOM detector belt is faulty and the TOP detector belt is operational, replace defective BOTTOM detector belt. Return system to service.

(1) Nose Detector Belt Fails

Connect Test Set Detector Cable, connector P1, to test set, connector J1.

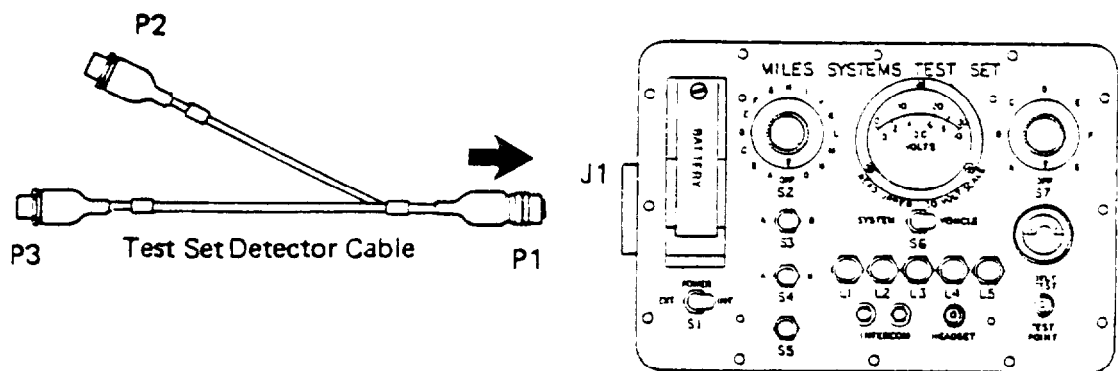

Place test set switch S1 to EXT.

Disconnect ACIA Interface Cable Assembly (W3), connector P5, from Nose Detector Belt.

Connect Test Set Detector Cable, connector P2, to Nose Detector Belt, and connector P3 to ACIA Interface Cable Assembly (W3), connector P5.

Place test set switch S6 to SYSTEM.

Read voltage on voltmeter

If voltage reading is less than 8.5 volts, replace defective ACIA Interface Cable Assembly (W3). Return system to service.

Table 3-2. Troubleshooting - With MSTS (Cont)

MALFUNCTION	TEST OR INSPECTION	CORRECTIVE ACTION
-------------	--------------------	-------------------

5. AIRCRAFT DETECTOR ASSEMBLIES TEST (CONT)

(1) Nose Detector Belt Fails (Cont)

NOTE

When firing Controller Gun at faulty detector belt. maintain a minimum of five feet between Controller Gun and detector belt. At distances less than five feet. a FALSE rate reading is possible.

If voltage reading is 8.5 to 13 volts, aim Controller Gun at Nose Detector Belt. Fire a "NEAR-MISS" signal. Check test set BELT TEST meter.

If BELT TEST meter rate is greater than 96, replace defective ACIA Interface Cable Assembly (W3). Return system to service.

If BELT TEST meter rate is less than 96, replace faulty Nose Detector Belt. Return system to service.

(2) Top Detector Belt Fails

Connector Test Set Detector Cable, connector P1, to test set, connector J1.

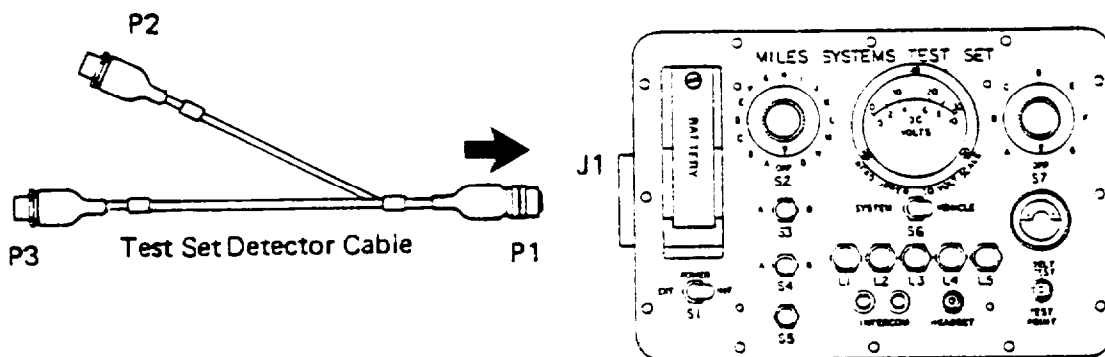

Place test set switch S1 to EXT.

Disconnect Top Detector Belt connector from Bottom Detector Belt cable.

Connect Test Set Detector Cable. connector P2, to Top Detector Belt connector. and connector P3, to Bottom Detector Belt connector.

MALFUNCTION

TEST OR INSPECTION

CORRECTIVE ACTION

Place test set switch S6 to SYSTEM.

Read voltage on voltmeter.

If voltage reading is less than 8.5 volts, replace defective Bottom Detector Belt. Return unit to service.

NOTE

When firing Controller Gun at faulty detector belt, maintain a minimum of five feet between Controller Gun and detector belt. At distances less than five feet, a FALSE rate reading is possible.

If voltage is 8.5 to 13 volts, aim Controller Gun at Top Detector Belt. Fire a "NEAR MISS" signal. Check test set BELT TEST meter.

If BELT TEST meter rate is less than 96, replace defective Top Detector Belt. Return system to service.

If BELT TEST meter rate is greater than 96, replace defective Bottom Detector Belt. Return system to service.

(3) Bottom Detector Belt Fails

If Bottom Detector Belt is faulty and Top Detector Belt on that side is operational replace defective Bottom Detector Belts. Return system to service

(4) Top And Bottom Belts On Same Side Fail

Connect Test Set Detector Cable, connector P1, to test set, connector J1.

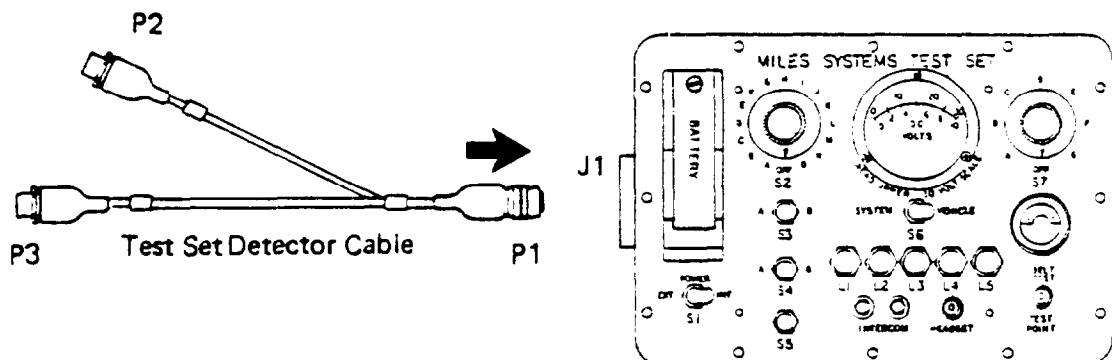

Table 3-2. Troubleshooting - With MSTs (Cont)

MALFUNCTION	TEST OR INSPECTION	CORRECTIVE ACTION
5. <u>AIRCRAFT DETECTOR ASSEMBLIES TEST (CONT)</u>	(4) Top And Bottom Belts On Same Side Fail (Cont)	<p>Disconnect ACIA Interface Cable Assembly (W3), connectors P4 or P6 (LEFT/RIGHT). from the suspect faulty Bottom Detector Belt connector. Connect Test Set Detector Belt. connector P2, to ACIA Interface Cable Assembly (W3) connector disconnected in last step (P4 or P6), and connector P3, to Bottom Detector Belt connector.</p> <p>Place test set switch S1 to EXT.</p> <p>Place test set swtich S6 to SYSTEM.</p> <p>Read voltage on voltmeter.</p> <p style="padding-left: 40px;">If voltage is less than 8.5 volts, replace defective ACIA Interface Cable Assembly (W3). Return unit to service.</p>
NOTE		
<p style="padding-left: 40px;">When firing Controller Gun at faulty detector belt, maintain a minimum of five feet between Controller Gun and detector belts. At distances less than five feet, a FALSE rate reading is possible.</p>		
<p>If voltage is 8.5 to 13 volts, aim Controller Gun at Top Detector Belt. Fire a "NEAR MISS" signal. Check test set BELT TEST meter.</p>		
<p style="padding-left: 40px;">If BELT TEST meter reading is greater than 96, replace defective ACIA Interface Cable Assembly (W3). Return system to service.</p>		
<p style="padding-left: 40px;">If BELT TEST meter reading is less than 96, replace defective Bottom Detector Belt. Return system to service.</p>		

MALFUNCTION

TEST OR INSPECTION

CORRECTIVE ACTION

(5) All Detector Belts Fail

Connect Test Set Interconnect Cable, connector P1, to test set, connector J1. Connect Test Set Interconnect Cable, connector P2, to Test Set Junction Box, connector J1.

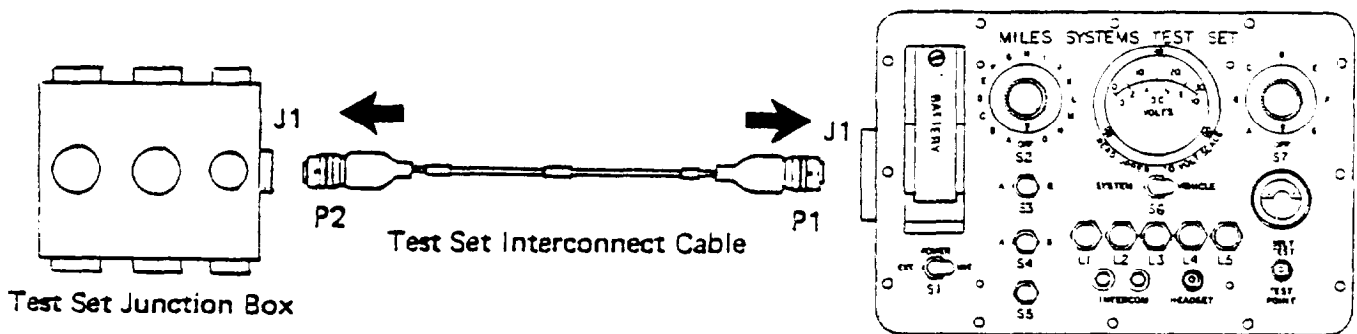

Place test set switch S1 to EXT.

Disconnect ACIA Interface Cable Assembly (W3), connector P1, from ACIA. Connect to Test Set Junction Box, connector J4

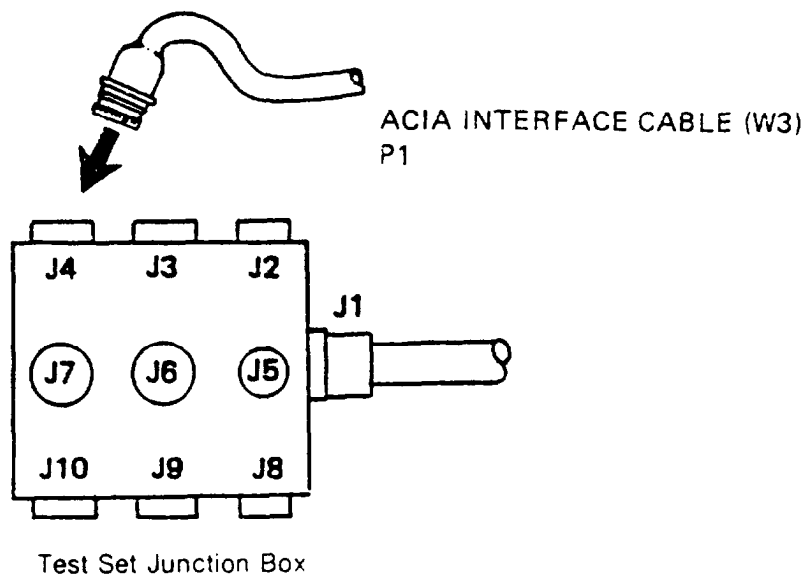

Table 3-2. Troubleshooting - With MSTs (Cont)

MALFUNCTION		
	TEST OR INSPECTION	
		CORRECTIVE ACTION

5. AIRCRAFT DETECTOR ASSEMBLIES TEST (CONT)

(5) All Detector Belts Fail (Cont)

Read rate from detector belts on test set BELT TEST meter See Table 3-2.1 to determine acceptable rate for 5 detector belts.

Table 3-2.1		
Detector Belt Rate		
<u>Number of Belts</u>	<u>Full Sun</u>	<u>Shade</u>
1	0 - 10	0 - 2
2	0 - 15	0 - 4
3	0 - 20	0 - 8
4	0 - 30	0 - 10
5	0 - 40	0 - 12

If BELT TEST meter rate is acceptable. go to (5.1) All Detector Belts Fail-Controller Gun Test.

If BELT TEST meter rate is unacceptable, disconnect NOSE Detector Belt or one of the TOP detector belts.

Read detector belt rate on test set BELT TEST meter. See Table 3-2.1 to determine acceptable rate for 4 detector belts.

If BELT TEST meter rate is acceptable, replace detector belt disconnected Return system to service.

If BELT TEST meter rate was unacceptable, reconnect detector belt previously disconnected. Repeat previous tests on remaining aircraft TOP or NOSE detector belts until faulty belt is isolated.

If both TOP and NOSE detector belts are checked and BELT TEST meter rate is still unacceptable, reconnect those belts. Disconnect one BOTTOM detector belt from ACIA Interface Cable Assembly (W3).

MALFUNCTION
TEST OR INSPECTION**CORRECTIVE ACTION**

Read detector belt rate on test set BELT TEST meter. See Table 3-2.1 to determine acceptable rate for 3 detector belts.

If BELT TEST meter rate is acceptable, replace defective BOTTOM detector belt. Return system to service.

If BELT TEST meter rate is not acceptable, reconnect BOTTOM detector belt to ACIA Interface Cable Assembly (W3).

Disconnect opposite side BOTTOM detector belt, from ACIA Interface Cable Assembly (W3).

Read detector belt rate one test set BELT TEST meter. See Table 3-2.1 to determine acceptable rate for 3 detector belts

If BELT TEST meter rate is acceptable. replace defective BOTTOM detector belt. Return system to service.

If BELT TEST meter rate is not acceptable, replace ACIA Interface Cable Assembly (W3). Return system to service.

(5.1) All Detector Belts Fail - Controller Gun Test

Aim Controller Gun at detector belts. Fire a "NEAR MISS" signal. Check BELT TEST meter.

NOTE

When firing Controller Gun at faulty detector belts, maintain a minimum of 5 feet between Controller Gun and detector belts. At distances less than 5 feet, a FALSE rate reading is possible.

If BELT TEST meter rate is greater than 96, replace defective ACIA Return system to service.

If BELT TEST meter rate is less than 96, disconnect RIGHT SIDE BOTTOM detector belt, connector P1, from ACIA Interface Cable Assembly (W3), connector P6.

Table 3-2. Troubleshooting - With MSTs (Cont)

MALFUNCTION	TEST OR INSPECTION	CORRECTIVE ACTION
5. AIRCRAFT DETECTOR ASSEMBLIES TEST (CONT)		
(5.1) All Detector Belts Fail - Controller Gun Test (Cont)		
	Aim Controller Gun at LEFT SIDE detector belts, Fire a "NEAR MISS" signal. Check test set BELT TEST meter.	
		If BELT TEST meter rate is less than 96, proceed to (5.2) All Detector Belts Fail - Controller Gun Test - NOSE
		If BELT TEST meter rate is greater than 96, reconnect RIGHT SIDE BOTTOM detector belt. Disconnect RIGHT SIDE TOP detector belt from BOTTOM detector Belt.
	Aim Controller Gun at LEFT SIDE detector belts. Fire a "NEAR MISS" signal. Check BELT TEST meter.	
		If BELT TEST meter rate is greater than 96, replace defective RIGHT TOP detector belt. Return system to service.
		If BELT TEST meter rate is less than 96, replace defective RIGHT BOTTOM detector belt. Return system to service.
(5.2) All Detector Belts Fail - Controller Gun Test-NOSE		
	Reconnect RIGHT SIDE BOTTOM detector belt. Disconnect LEFT SIDE BOTTOM detector belt, connector P1, from ACIA Interface Cable Assembly (W3), connector P4.	
	Arm Controller Gun at RIGHT SIDE detector belts Fire a "NEAR MISS" signal. Check test set BELT TEST meter.	
		If BELT TEST meter rate is greater than 96, proceed to (5.3) All Detector Belts Fail - Controller Gun Test - LEFT.

MALFUNCTION

TEST OR INSPECTION

CORRECTIVE ACTION

If BELT TEST meter rate is less than 96, disconnect NOSE Belt.

Aim Controller Gun at RIGHT SIDE detector belts. Fire a "NEAR MISS" signal. Check test set BELT TEST meter.

If BELT TEST meter rate is greater than 96, replace defective NOSE detector belt. Return system to service.

If BELT TEST meter rate is less than 96, replace defective ACIA Interface Cable Assembly (W3). Return system to service.

(5.3) All Detector Belts Fail-Controller Gun Test-LEFT

Reconnect LEFT SIDE BOTTOM Detector Belt. Disconnect LEFT SIDE TOP detector belt from BOTTOM detector belt.

Aim Controller Gun at RIGHT SIDE detector belts, Fire a "NEAR MISS" signal. Check test set BELT TEST meter.

If BELT TEST meter rate is greater than 96, replace defective TOP LEFT detector belt. Return system to service.

If BELT TEST meter rate is less than 96, replace defective BOTTOM LEFT detector belt. Return system to service.

Table 3-2. Troubleshooting - With MSTS (Cont)

MALFUNCTION	TEST OR INSPECTION	CORRECTIVE ACTION
-------------	--------------------	-------------------

6. HEADSETS TEST

(1) Headsets Fail

Connect Test Set Interconnect Cable, connector P1, to test set, connector J1. Connect Test Set Interconnect Cable, connector P2, to Test Set Junction Box, connector J1.

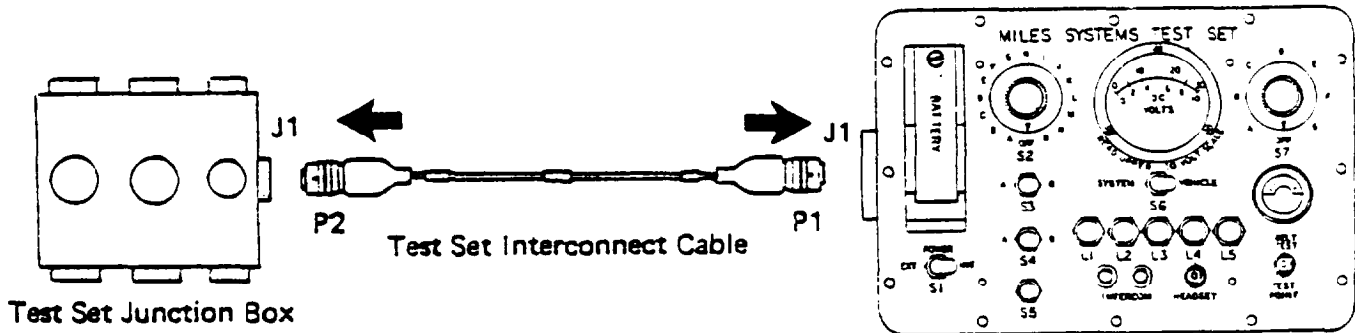

Place test set switch S1 to EXT.

Disconnect ACIA Interface Cable Assembly (W3), connector P2, from CKI. Connect to Test Set Junction Box, connector J7.

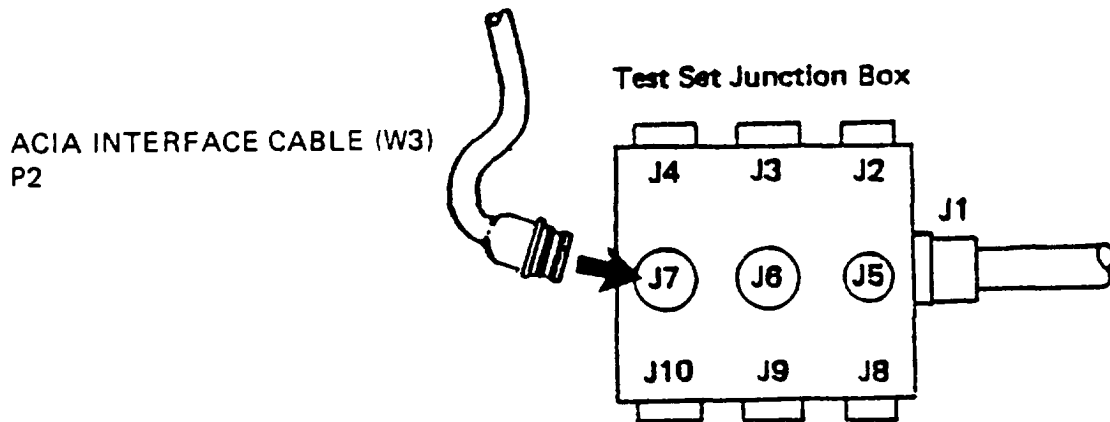

MALFUNCTION

TEST OR INSPECTION

CORRECTIVE ACTION

Place test set switch S2 to 0. (Note that test set indicator lights L2 and L4 may come ON. These indications have no effect on troubleshooting procedures.)

Place test set switch S7 to A.

Insert Controller Key into WEAPON Key receptacle on ACIA. Turn key counterclockwise to CONTROLLER position. Turn back and remove key.

insert Vehicle (Orange) Key into WEAPON Key receptacle on ACIA. Turn clockwise to "SELF KILL" system. Turn back and remove key

Check test set BELT TEST meter

If BELT TEST meter rate is less than 50, proceed to (1.1) Headsets Fail - Audio Tone.

If BELT TEST meter rate is greater than 50, disconnect ACIA Interface Cable Assembly (W3), from Test Set Junction Box. Connect to CKI.

Disconnect Headset Cable with suspect fault from CKI. Connect to test set connector labeled HEADSET.

Place test set switch S7 to 8.

Install 9 V battery in test set.

Place test set switch to INT.

Depress S5. Verify AUDIO TONE is heard in aircraft headset

If AUDIO TONE is present, replace defective CKI. Return system to service.

If no AUDIO TONE is present, verify aircraft headset is operational.

If headset is not operational, repair all malfunctions. Return unit to service.

If headset is operational, replace Headset Cable. Return unit to service

Table 3-2. Troubleshooting - With MSTs (Cont)

MALFUNCTION	TEST OR INSPECTION	CORRECTIVE ACTION
-------------	--------------------	-------------------

6. HEADSETS TEST (CONT)

(1 1) Headset Fail -Audio Tone

Disconnect ACIA Interface Cable Assembly (W3), from Test Set Junction Box. Reconnect to CKI. Ensure Headset Cable in question is connected to CKI.

Disconnect ACIA Interface Cable Assembly (W3), connector P1, from ACIA. Connect to Test Set Junction Box, connector J4.

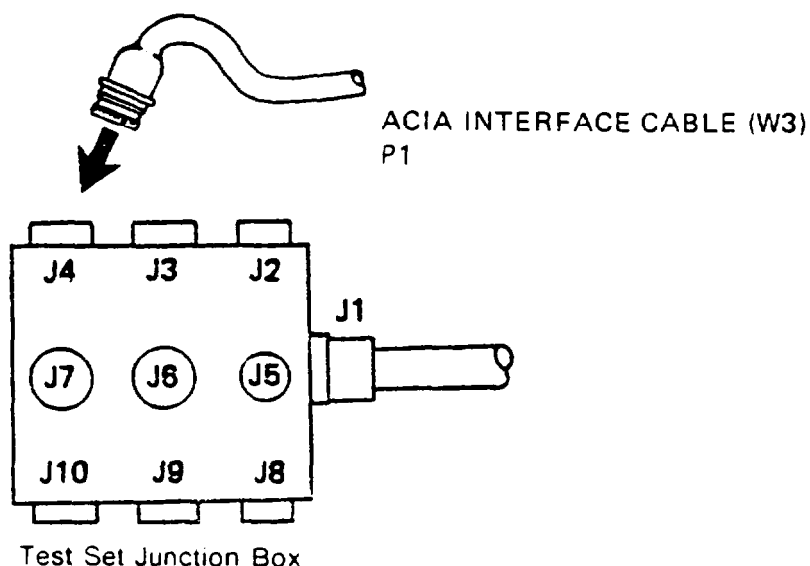

Place test set switch S7 to B. Depress test set switch S5. Listen for AUDIO TONE in aircraft headset.

If AUDIO TONE is present, replace defective ACIA. Return system to service.

If no AUDIO TONE present. replace defective ACIA Interface Cable Assembly (W3). Return system to service.

CHAPTER 4

AMMUNITION



AR 101029A

WARNINGS

Never carry hand grenades or handle them by safety pull ring attached to safety pin.

Handle grenade canisters with care at all times.

Expended canisters may be initially hot to touch. Wait 5 minutes after being fired before attempting to remove.

Dispose of malfunctioning and expended grenade canisters in accordance with EOD procedures.

The M18 Smoke Hand Grenades (Yellow) (NSN 1330-00-289-6854) are the only grenade canisters authorized to be fired during MILES training simulations on helicopters.

APPENDIX A

REFERENCES

A-1. SCOPE

This appendix lists all Forms, Field Manuals, Technical Manuals and miscellaneous publications referenced in this manual.

A-2. FORMS

SF 368	Quality Deficiency Report
DA Form 2028-2	Recommended Changes to DA Publications
DA Form 2062	Hand Receipt
DA Form 2402	Exchange Tag
DA Form 2404	Equipment Inspection and Maintenance Work Sheet

A-3. FIELD MANUALS

FM 21-11	Field Manual: First Aid for Soldiers
----------	--------------------------------------

A-4. TECHNICAL MANUALS

TM 9-1270-222-10-HR	Hand Receipt for Simulator System, Firing, Laser: M78 for OH-58 Helicopter
TM 55-1520-228-10	Operator's Manual. Army Model OH-58A Helicopter
TM 55-1520-235-10	Operator's Manual. Army Model OH-58C Helicopter

A-5. MISCELLANEOUS PUBLICATIONS

AR 310-2	Identification and Distribution of DA Publications
SB 11-6	Dry Battery Supply Data
DA PAM 738-750	The Army Maintenance Management System

APPENDIX B

COMPONENTS OF END ITEM AND BASIC ISSUE ITEMS LISTS

SECTION I. INTRODUCTION

B-1. SCOPE

This appendix lists components of end item and basic issue items for the MILES OH-58 Helicopter System to help you inventory items required for safe and efficient operation.

B-2. GENERAL

The Components of End Item and Basic Issue Items Lists are divided into the following sections:

a. Section II, Components of End Item. This listing is for informational purposes only, and is not authority to requisition replacements. These items are part of the end item, but are removed and separately packaged for transportation or shipment. As part of the end item, these items must be with the end item whenever it is issued or transferred between property accounts. Illustrations are furnished to assist you in identifying the items.

b. Section III, Basic Issue Items. These are the minimum essential items required to place the MILES OH-58 helicopter system in operation, to operate it, and to perform emergency repairs. Although shipped separately packaged, BII must be with the MILES OH-58 helicopter system during operation and whenever it is transferred between property accounts. The illustrations will assist you with hard-to-identify items. This manual is your authority to request/requisition replacement BII, based on TOE/MTOE authorization of the end item.

B-3. EXPLANATION OF COLUMNS

The following provides an explanation of columns found in the tabular listings:

a. Column (1) - Illustration Number. This column indicates the number of the illustration in which the item is shown.

b. Column (2) - National Stock Number. Indicates the National stock number assigned to the item and will be used for requisitioning purposes. **NOTE**

National stock numbers (NSNs) have not been assigned to all COEI, BII, and AAL items because these items are presently supported by contractor logistics support (CLS). When decision is made to assume Government support, NSNs will be assigned, and hand receipt entries (columns a, c, d, and e) will be furnished.

c. Column (3) - Description. Indicates the Federal item name and, if required a minimum description to Identify and locate the item. The last line for each item indicates the FSCM (in parentheses) followed by the part number.

d. Column (4) - Unit of Measure (U/M). Indicates the measure used in performing the actual operational/maintenance function. This measure is expressed by a two-character alphabetical abbreviation (e.g.. ea, in. pr).

e. Column (5) - Quantity required (Qty rqr). Indicates the quantity of the item authorized to be used with/on the equipment.

SECTION II. COMPONENTS OF END ITEM

(1) Illustration Number	(2) National Stock Number	(3) Description FSCM & Part Number Usable On Code	(4) U/M	(5) Qty. rqr.
1	*	Adapter Assembly, Cockpit Kill Indicator (19200) 9339399-3	EA	1
2	*	Adapter Assembly, Simulator System, Laser: Console (19200) 9339393	EA	1
3	*	Adapter Set, Simulator System, Laser: OH-58 Helicopter (19200) 9339549	EA	1
Line Item/Part Number 9339549 consists of the following components:				
3-A	*	Belt End Assembly (19200) 9340103	EA	2
3-B	*	Cable Assembly, AKI/Smoke-ACIA (W2) (19200) 9340051-1	EA	1
3-C	*	Cable Assembly, Headset-CKI (W1) (19200) 9340056-2	EA	2

*Not Available on Publication Date.

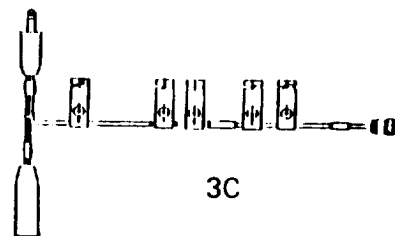
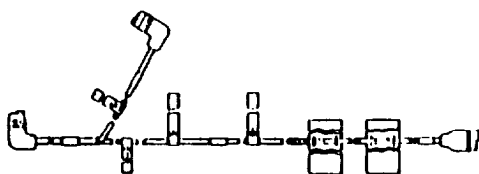
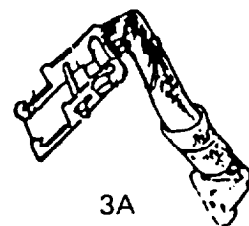
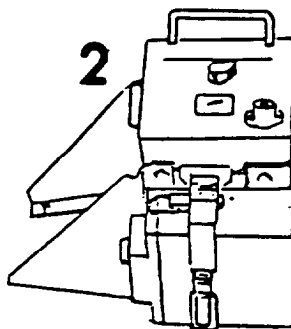
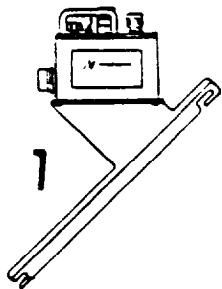

Section II. COMPONENTS OF END ITEM (Cont)

(1) Illustration Number	(2) National Stock Number	(3) Description FSCM & Part Number Usable On Code	(4) U/M	(5) Qty. rqr.
3-D	*	Cable Assembly, OH-58, ACIA INTFC (W3) (19200) 9340050	EA	1
3-E	*	CKI Adapter (19200) 9344626	EA	1
3-F	*	Harness, Rear Assembly (19200) 9340027	EA	1
3-G	*	Nut, Self Locking 3/8-16 UNC-3B MS17829-C6	EA	4
3-H	*	Ring Assy, OH-58 (19200) 9344552	EA	2
3-1	5310-00-167-0821	Washer, Flat 3/8 AN 960C616	EA	8
3-J	5310-00-984-7042	Washer, Lock 3/8 MS 35338-141	EA	4

*Not Available on Publication Date.

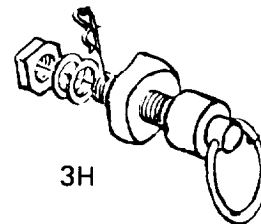
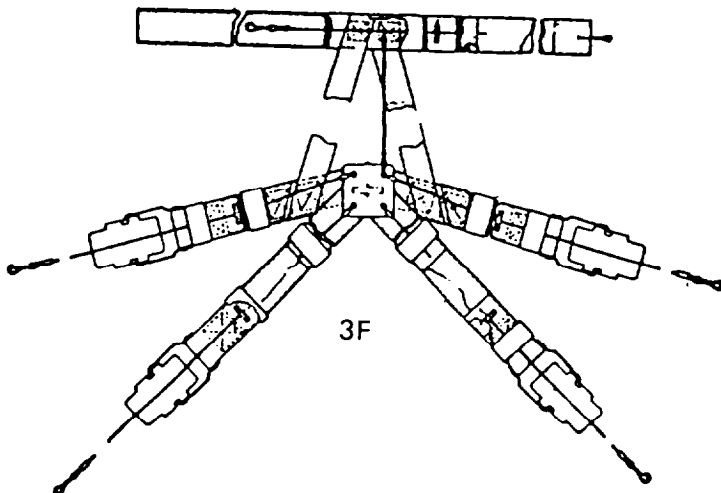
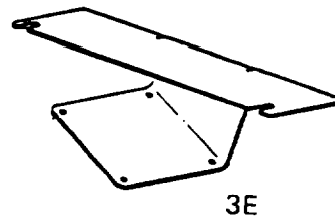
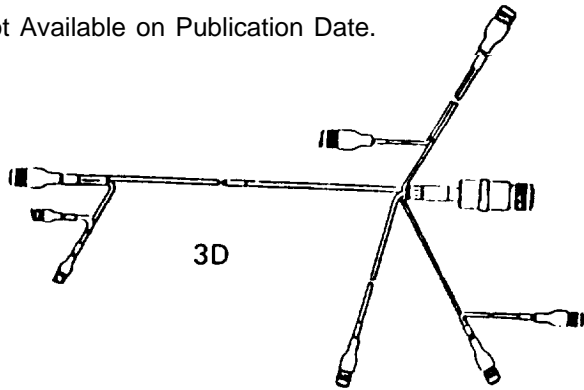

(1) Illustration Number	(2) National Stock Number	(3) Description FSCM & Part Number Usable On Code	(4) U/M	(5) Qty rqr.
4	*	Detector Belt Assembly, Aircraft Segment No. 7, (19200) 9339544	EA	1
5	*	Detector Belt Assembly, Aircraft Segment No. 6, (19200) 9339543	EA	2
6	*	Detector Belt Assembly, Aircraft Segment No. 5, (19200) 9339542	EA	2
7	*	Indicator, Assembly, Simulator System, Laser: Kill/Hit/Miss (19200) 9339397	EA	1
8	*	Installation Kit, OH-58A Helicopter (19200) 9339417	EA	1
9	*	Manual Operator's, TM9-1270-222-10	EA	1
10	*	Transit Case Assembly (19200) 9339562	EA	1

*Not Available on Publication Date.

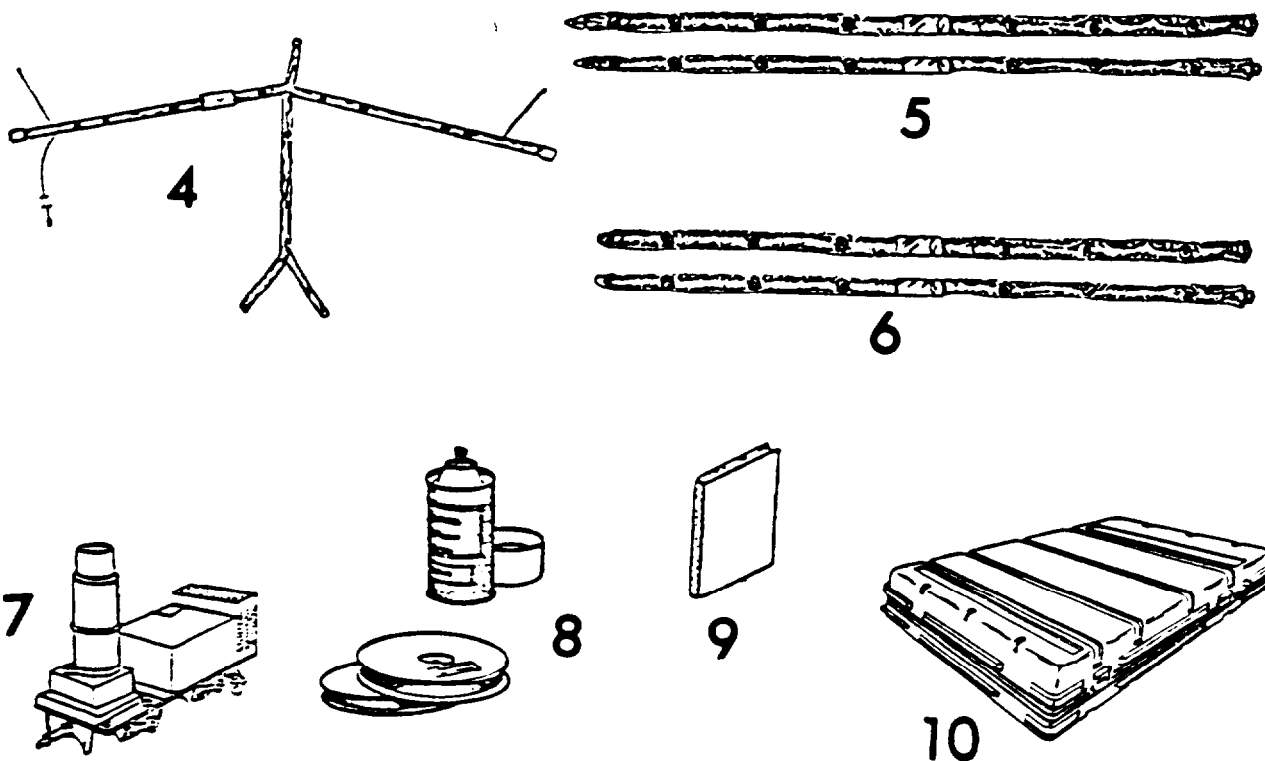

SECTION III. BASIC ISSUE ITEMS

None authorized.

APPENDIX C
ADDITIONAL AUTHORIZATION LIST

SECTION I. INTRODUCTION

C-1. SCOPE

This appendix lists additional items you are authorized for the support of the MILES OH-58 system

C-2. GENERAL

This list identifies items that do not have to accompany the MILES OH-58 and that do not have to be turned in with it. These items are all authorized to you by either CTA, MTOE, TDA, or JTA.

C-3. EXPLANATION OF LISTING

National stock numbers, descriptions, and quantities are provided to help you identify and request the additional items you require to support this equipment. The items are listed in alphabetical sequence by item name.

SECTION II. ADDITIONAL AUTHORIZATION LIST

(1) Item Number	(2) National Stock Number	(3) Description FSCM & Part Number	(4) U/M	(5) Qty Auth
1	1265-01-092-0891	Controller's Gun (19200) 11748611	EA	1
2	*	MILES System Test Set (19200) 9358670	EA	1
3	5120-00-243-9401	Roller, Hand	EA	1

*Not Available on Publication Date.

APPENDIX D
EXPENDABLE/DURABLE SUPPLIES AND MATERIALS LIST

SECTION I. INTRODUCTION

D-1. SCOPE

This appendix lists expendable supplies and materials you will need to operate and maintain the MILES OH-58 System. These items are authorized to you by CTA 50-970, Expendable Items (Except Medical, Class V, Repair Parts and Heraldic Items).

D-2. EXPLANATION OF COLUMNS

a. Column (1) - Item number. This number is assigned to the entry in the listing and is referenced in the narrative instructions to identify the material

b. Column (2) - Level This column identifies the lowest level of maintenance that requires the listed item.

C Operator/Crew

c. Column (3) - National Stock Number. This is the National stock number assigned to the item: use it to request or requisition the item.

d. Column (4) - Description. Indicates the Federal item name and, if required a description to identify the item. The last line for each item indicates the Federal Supply Code for Manufacturer (FSCM) in parentheses followed by the part number.

e. Column (5) - Unit of Measure (U/M). Indicates the measure used in performing the actual maintenance function. This measure is expressed by a two-character alphabetical abbreviation (e.g., ea, in, pr). If the unit of measure differs from the unit of issue requisition the lowest unit of issue that will satisfy your requirements.

SECTION II. EXPENDABLE/DURABLE SUPPLIES AND MATERIALS LIST

(1) Number	(2) Level	(3) National Stock Number	(4) Description FSCM & Part Number Usable On Code	(5) U/M
1	C, O	6135-00-050-3280	* Battery, 6 volt (80058) BA200/U	EA
2	C, O	8010-01-040-0947	Primer, Tape (19200) 11749034	OZ
3	C, O	8315-01-111-7170	Fastener Tape (19200) 11749428	YD
4	C, O	7920-00-225-7536	Brush, Cleaning	EA
5	C, O	6640-00-240-5851	Paper, Lens Cleaning (81349) NNN-P-40	PK
6	C, O	7920-00-205- 1711	Rag, Wiping: Cot DDD-R-30, CL 12, GR B	LB
7	C, O	7510-00-266-6694	Tape, Masking, 3" Wide (or equivalent) (81348) PPP-T-42	YD
8	C, O	1330-00-289-6854	Grenade, Hand, Smoke, M18 (Yellow)	EA

* Dry battery listed is used with the equipment. It will not be preshipped automatically but is to be requisitioned in quantities necessary for the particular organization in accordance with SB 11-6.

INDEX

Subject	Page Number
A	
Abbreviations	1-3
Additional Authorization List	C-1
Aircraft Control Indicator Assembly	
Checks and Services	2-5
Controls and Indicators	2-3
General Operation	1-10
Installation	2-42
Location and Description	1-7
Aircraft Kill Indicator	
Checks and Services	2-5
General Operation	1-10
installation	2-38
Location and Description	1-6
B	
Battery Box Assembly	
Battery Installation	2-42
Checks and Services	2-5
Installation	2-42
Location and Description	1-7
Buckles. Mating of	2-25
C	
Cabling	
Checks and Services	2-5
Installation	2-46
Characteristics, Technical	1-8
Checks and Services	2-5
Cockpit Kill Indicator	
Checks and Services	2-5
Controls and Indicators	2-1
General Operation	1-11
Installation	2-44
Location and Description	1-7
Components of End Item	B-1

INDEX (CONT)

Subject	Page Number
D	
Detector Belts	
Checks and Services	2-5
General Operation	1-10
Installation	2-18
Location and Description	1-6
Mating Side Belt Connectors	2-36
Tension Adjustment	2-32
Dimensions	1-8
E	
Expendable Supplies and Materials List	D-1
F	
Fastener Tape Installation	2-11
Features	1-5
G	
Glossary	1-4
Grenade installation (see Smoke Grenade Installation)	
I	
Inside Installation Tasks	2-40
Inspection	2-5
K	
Kill Indication	2-11
L	
Laser Warning	Inside front cover
Location of Major Components	1-6
M	
Maintenance	
Preventive Checks and Services	2-4
N	
Nomenclature Cross Reference List	1-3

INDEX (CONT)

Subject	Page Number
O	
Operation	
Technical Principles	1-10
Tasks	2-68
Outside Preparation	2-9
P	
Postoperational Tasks	2-79
Preventive Maintenance Checks and Services	2-4
R	
References	A-1
Removing MILES Equipment	2-79
Resetting After a Kill	2-77
S	
Smoke Grenade Installation	2-73
Smoke indicator	
Checks and Services	2-5
General Operation	1-10
Installation	2-38
Location and Description	1-6
Storing MILES Equipment	2-81
T	
Tasks	
Cabling Installation	2-46
Inside Installation	2-40
Operational	2-69
Outside Installation	2-14
Outside Preparation	2-9
Postoperational	2-79
Test	2-62
Technical Characteristics	1-8
W	
Warnings	Inside front cover
Weights and Dimensions	1-8
Weights and Balances	1-9

By Order of the Secretary of the Army:

Official:

JOHN A .WICKHAM, JR.
General, United States Army
Chief of Staff

ROBERT M. JOYCE
Major General, United States Army
The Adjutant General

Distribution:

To be distributed in accordance with Special Distribution List.



THEN... JOT DOWN THE DOPE ABOUT IT ON THIS FORM. CAREFULLY TEAR IT OUT. FOLD IT AND DROP IT IN THE MAIL!

SOMETHING WRONG WITH THIS PUBLICATION?

FROM: (PRINT YOUR UNIT'S COMPLETE ADDRESS)

Your mailing address

DATE SENT

Date you send in form

PUBLICATION NUMBER
EM 9-1270-222-10

PUBLICATION DATE

PUBLICATION TITLE (MILES)
SIMULATOR SYSTEM, FIRING, LASER:
FOR OH-58A OBSERVATION HELICOPTER

BE EXACT. PIN-POINT WHERE IT IS

PAGE NO.	PARA-GRAPH	FIGURE NO.	TABLE NO.
8	5		
12	1		
12	7		
14	4		

IN THIS SPACE TELL WHAT IS WRONG AND WHAT SHOULD BE DONE ABOUT IT:

Line 5. Change spelling of word unitl to read until

Change the word harnesses to read harness

Change to read: Ask controller to insert his green key into the key receptacle and turn off alarm.

Delete the word it from sentence

SAMPLE

TEAR ALONG PERFORATED LINE

PRINTED NAME, GRADE OR TITLE AND TELEPHONE NUMBER

JOHN SMITH SP/3 XXX-XXXX

SIGN HERE:

John Smith

DA FORM 2028-2
1 JUL 79

PREVIOUS EDITIONS ARE OBSOLETE.

U.S.—IF YOUR UNIT WANTS TO KNOW ABOUT YOUR RECOMMENDATION MAKE A CARBON COPY OF THIS AND GIVE IT TO YOUR HEADQUARTERS.

RECOMMENDED CHANGES TO EQUIPMENT TECHNICAL PUBLICATIONS



THEN JOT DOWN THE DOPE ABOUT IT ON THIS FORM. CAREFULLY TEAR IT OUT. FOLD IT AND DROP IT IN THE MAIL.

SOMETHING WRONG WITH THIS PUBLICATION?

FROM (PRINT YOUR UNIT'S COMPLETE ADDRESS)

DATE SENT

PUBLICATION NUMBER

TM 9-1270-222-10

PUBLICATION DATE

22 Oct 84

PUBLICATION TITLE (MILES) Simulator

System, Firing, Laser: for OH-58A

BE EXACT PIN-POINT WHERE IT IS

PAGE NO	PARA-GRAPH	FIGURE NO	TABLE NO

IN THIS SPACE TELL WHAT IS WRONG AND WHAT SHOULD BE DONE ABOUT IT:

TEAR ALONG PERFORATED LINE

PRINTED NAME GRADE OR TITLE AND TELEPHONE NUMBER

SIGN HERE

DA FORM 2028-2 1 JUL 79

PREVIOUS EDITIONS ARE OBSOLETE.

DRSMC OP-16-83

PS--IF YOUR OUTFIT WANTS TO KNOW ABOUT YOUR RECOMMENDATION MAKE A CARBON COPY OF THIS AND GIVE IT TO YOUR HEADQUARTERS

FILL IN YOUR
UNIT'S ADDRESS

FOLD BACK

DEPARTMENT OF THE ARMY

OFFICIAL BUSINESS
PENALTY FOR PRIVATE USE \$300

POSTAGE AND FEES PAID
DEPARTMENT OF THE ARMY
DOD 314



TEAR ALONG

PERFORATED LINE

Commander
US Army Armament, Munitions and Chemical Command
ATTN: DRSMC-MAS (R)
Rock Island, IL 61299

THE METRIC AND EQUIVALENTS

LINEAR MEASURE

1 Centimeter= 10 Millimeters= 0.01 Meters= 0.3937 Inches
 1 Meter= 100 Centimeters= 1000 Millimeters= 39.37 Inches
 1 Kilometer= 1000 Meters= 0.621 Miles

WEIGHTS

1 Gram= 0.001 Kilogram= 1000 Milligrams= 0.035 Ounces
 1 Kilogram= 1000 Grams= 2.2 Lb
 1 Metric Ton= 1000 Kilograms= 1 Megagram= 1.1 Short Tons

LIQUID MEASURE

1 Milliliter= 0.001 Liters= 0.035 Ounces
 1 Liter= 1000 Milliliter= 33.82 Fluid Ounces

SQUARE MEASURE

1 Sq Centimeter= 100 Sq Millimeters= 0.155 Sq Inches
 1 Sq Meter= 10,000 Sq Centimeters= 10.76 Sq Feet
 1 Sq Kilometer= 1,000,000 Sq Meters= 0.386 Sq Miles

CUBIC MEASURE

1 Cu Centimeters= 1000 Cu Millimeter= 0.06 Cu Inches
 1 Cu Meter= 1,000,000 Cu Centimeters= 35.31 Cu Feet

TEMPERATURE

$5/9 (^{\circ}\text{F}-32)-^{\circ}\text{C}$
 212° Fahrenheit is equivalent to 100° Celsius
 90° Fahrenheit is equivalent to 32.2° Celsius
 32° Fahrenheit is equivalent to 0° Celsius
 $9/5\text{C}^{\circ}+32=\text{F}^{\circ}$

APPROXIMATE CONVERSION FACTORS

<u>TO CHANGE</u>	<u>TO</u>	<u>MULTIPLY BY</u>
Inches	Centimeters.	2.540
Feet	Meters	0.305
Yards	Meters	0.914
Miles	Kilometers	1.609
Square Inches	Square Centimeters	6.451
Square Feet	Square Meters.	0.093
Square Yards.	Square Meters.	0.836
Square Miles.	Square Kilometers.	2.590
Acres	Square Hectometers	0.405
Cubic Feet.	Cubic Meters	0.028
Cubic Yards	Cubic Meters	0.765
Fluid Ounces.	Milliliters.	29.573
Pints	Liters	0.473
Quarts.	Liters	0.946
Gallons	Liters	3.785
Ounces.	Grams.	28.349
Pounds.	Kilograms.	0.454
Short Tons.	Metric Tons.	0.907
Pound-Feet.	Newton-Meters.	1.356
Pounds per Square inch.	Kilopascals.	6.895
Miles per Gallon.	Kilometers per Liter	0.425
Miles per Hour.	Kilometers per Hour.	1.609

<u>TO CHANGE</u>	<u>TO</u>	<u>MULTIPLY BY</u>
Centimeters	Inches	0.394
Meters.	Feet	3.280
Meters.	Yards.	1.094
Kilometers.	Miles.	0.621
Square Centimeters.	Square Inches	0.155
Square Meters	Square Feet.	10.764
Square Meters	Square Yards	1.196
Square Kilometer.	Square Miles	0.386
Square Hectometers	Acres.	2.471
Cubic Meters.	Cubic Feet	35.315
Cubic Meters.	Cubic Yards.	1.308
Milliliters	Fluid Ounces	0.034
Liters	Pints.	2.113
Liters.	Quarts	1.057
Liters	Gallons	0.264
Grams	Ounces	0.035
Kilograms	Pounds	2.205
Metric Tons	Short Tons	1.102
Newton-Meters	Pound-Feet	0.738
Kilopascals	Pounds per Square Inch	0.145
Kilometers per Liter.	Miles per Gallon	2.354
Kilometers per Hour	Miles per Hour	0.621

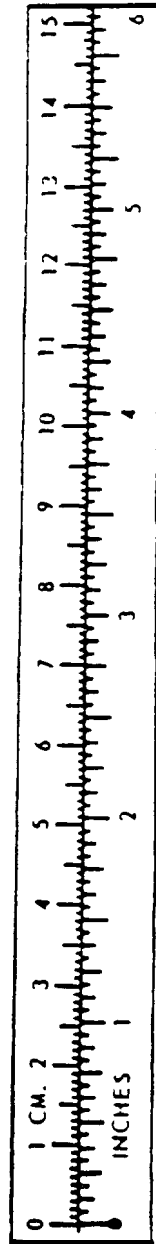

PIN: 056887-000